

产品目录

PRODUCT CATALOG



Notes for this Product Catalog

- All the products comply with RoHS Directives
- Dimensions without tolerance are for reference, Dimension H (Height of Products) is max.
- All information and data presented in this Product Catalog are for reference only.
- Custom designs are available to meet the customer's exact requirements.

1、Product Index 产品目录

产品类别 Product Categories	产品系列 Product Series	页码 Page
磁胶电感 Magenetic Epoxy Coating Power Inductors	KTNR-S (Ferrite Series)	P5~19
	KTNR-A (Alloy Series)	P20~22
一体成型电感 Molding Power Inductors	MHF Mini Molding Power Inductors	P23~32
	MTA(Alloy Powder)	P33~42
屏蔽电感 Shielded Power Inductors	KTDRH103R,104R,105R	P43~45
	KTDRH124,125,127,129	P46~50
	KTDRH74	P51
	KT3D16,4D28,5D18,5D28,6D28,6D38	P52~55
开磁电感 Unshielded Power Inductors	CD3521,4532,5830,5845,7850,7862,7870,1054	P56~62
	CBF1608C	P63
	SBF3316M,3340M,5022M	P64~65
大电流电感 Ultra High Current Power Inductors	DEP1256H,1349S	P66
	HCBD323023,403025,853225	P67
片式共模电感 Chip Common Mode Chokes	CMSC4520,7060,9070,1211,1513	P68~70
	CMDI1608,2012,2520,3216,3225,4532	P71~74
	CMDR5020S,5040S	P75
	CMTR0602S,0904S,0905S	P76~78
精密绕线电感 Wire Wound Chip Inductors	KTW-Ceramic(陶瓷)	P79~87
	KTW-Ferrite(铁氧体)	P88~93
	KTW-T Ferrite(铁氧体)	P94~96
叠层电感、磁珠 Multilayer Ferrite Inductors,Beads	电感 HPL1608,2012,2016,2520	P97~99
	电感 ML1608,2012,2016,2520,3216	P100~103
	磁珠 FB1005,1608,2012,3216	P104~110
插件电感 Through Hole Inductors	TDR0406,0507,0608,0610,0612	P111~112
	TDR0810,0912,1012,1016,1419,1618	P113~114

2、SMD Power Inductors Selection Guide by height/贴片功率电感选型指南（按高度检索） P3~4

3、Appendix

General Characteristics SMD Power Inductors/贴片功率电感通用特性 P115

Reflow Soldering Conditions/回流焊接条件 P116

SMD Power Inductors Selection Guide by height/贴片功率电感选型指南（按高度检索）

Height-mm	Type	Shielded	Page	L-mm	W-mm	Lmin-uH	Lmax-uH	Imin-A	Imax-A
0.8	MHF141208	YES	P24	1.4	1.2	0.24	0.47	3.3	3.7
	MHF160808	YES	P24	1.6	0.8	0.47	2.2	1.2	2.3
	MHF201208	YES	P25	2.0	1.2	0.24	2.2	1.8	5.9
1.0	MHF201610	YES	P27	2.0	1.6	0.22	10	0.7	6.3
	KTNR201610A	YES	P21	2.0	1.6	0.16	10	0.45	3.2
	MHF252010	YES	P28	2.5	2.0	0.24	10	0.95	6.4
	KTNR252010A	YES	P21	2.5	2.0	0.33	10	0.8	3.5
	KTNR252010S	YES	P7	2.5	2.0	0.22	22	0.45	2.7
	MTA4012S	YES	P34	4.4	4.2	0.15	4.7	1.45	6.8
1.2	KTNR252012A	YES	P21	2.5	2.0	0.24	10	0.85	4.05
	KTNR252012S	YES	P7	2.5	2.0	0.22	22	0.38	2.2
	MHF252012	YES	P28	2.5	2.0	0.24	10	1.05	7.5
	KTNR3012A	YES	P22	3.0	3.0	0.33	10	1.0	4.2
	KTNR3012S	YES	P8	3.0	3.0	0.22	100	0.21	3.0
	MHF322512	YES	P30	3.2	2.5	0.24	10	1.8	8.5
	KTNR4012A	YES	P22	4.0	4.0	0.33	22	0.9	4.3
	KTNR4012S	YES	P9	4.0	4.0	0.47	100	0.25	3.3
1.5	KTNR6012S	YES	P14	6.0	6.0	1.0	100	0.35	3.5
	KTNR3015S	YES	P8	3.0	3.0	0.5	150	0.18	2.6
1.6	KT3D16S	YES	P53	3.8	3.8	0.33	33	0.26	3.6
	MTA5018S	YES	P35	5.4	5.2	0.47	10	2.0	9.5
	MTA6018S	YES	P36	7.0	6.6	0.1	22	1.4	23
1.8	KT5D18S	YES	P54	5.7	5.7	3.3	100	0.37	2.04
	KTNR4018S	YES	P10	4.0	4.0	0.47	220	0.17	4.0
	MTA4020S	YES	P35	4.4	4.2	0.1	22	0.9	11.2
	MTA6020S	YES	P36	7.0	6.6	4.7	10	2.24	3.44
2.0	KTNR4020A	YES	P22	4.0	4.0	0.22	10	2.0	8.2
	KTNR4020S	YES	P10	4.0	4.0	0.24	100	0.31	4.5
	KTNR5020S	YES	P12	5.0	5.0	0.22	120	0.4	5.3
	KTNR6020S	YES	P14	6.0	6.0	1.5	330	0.27	3.2
2.2	MTA6024S	YES	P36	7.0	6.6	0.22	22	1.6	19.0
2.4	CD3521S	No	P57	3.5	3.0	1.0	100	0.22	1.85
2.8	CBF1608C	No	P63	6.6	4.45	1.0	1000	0.07	2.9
	KT4D28S	YES	P53	4.7	4.7	1.2	180	0.22	2.61
	KT5D28S	YES	P54	5.7	5.7	2.5	100	0.43	2.65
	KT6D28S	YES	P55	6.7	6.7	2.2	100	0.55	3.5
	KTNR6028S	YES	P15	6.0	6.0	0.82	1000	0.18	5.2
	MTA1030S	YES	P38	11.5	10.0	0.22	33	2.2	28.1
	MTA5030S	YES	P35	5.4	5.2	0.1	10	2.8	23
	MTA6030S	YES	P36	7.0	6.6	0.22	47	1.2	21.0
3.0	KTNR4030S	YES	P11	4.0	4.0	0.47	680	0.14	5.2

SMD Power Inductors Selection Guide by height/贴片功率电感选型指南 (按高度检索)

Height-mm	Type	Shielded	Page	L-mm	W-mm	Lmin-uH	Lmax-uH	Imin-A	Imax-A
3.1	KTDRH103R	YES	P44	10.2	10.0	1.5	220	0.75	7.0
3.5	CD4532S	No	P58	4.5	4.0	1.0	680	0.13	3.5
3.8	KT6D38S	YES	P55	6.7	6.7	3.3	100	0.66	3.57
	MTA1040S	YES	P39	11.5	10.0	0.15	100	1.7	10
	MTA6040S	YES	P37	7.0	6.6	0.68	47	1.44	13.6
	MTA8040S	YES	P38	8.0	8.5	1.0	68	2.1	12.0
4.0	KTDRH104R	YES	P44	10.2	10.0	1.0	1000	0.32	10
	KTNR5040S	YES	P13	5.0	5.0	0.22	4700	0.08	6.5
	KTNR8040S	YES	P17	8.0	8.0	0.82	1500	0.26	6.3
	MTA1240S	YES	P40	13.45	12.8	0.22	22	3.8	38
4.5	CD5845H	No	P59	5.8	5.2	500	5000	0.12	0.45
	CD5845S	No	P59	5.8	5.2	1.0	820	0.17	3.5
	KTDRH124S	YES	P47	12.2	12.2	1.0	1500	0.29	12.0
	KTNR6045S	YES	P16	6.0	6.0	0.47	1500	0.21	6.5
4.8	KTDRH105R	YES	P45	10.2	10.0	1.5	4700	0.2	10.5
	MTA1050S	YES	P39	11.5	10.0	0.22	100	1.8	31.5
	MTA1250S	YES	P40	13.45	12.6	0.22	47	2.6	45
	MTA6050S	YES	P37	7.0	6.6	0.47	68	1.35	17.0
	MTA8050S	YES	P38	8.0	8.5	1.0	100	1.8	12.0
5.0	CD7850H	No	P60	7.8	7.0	1000	8000	0.15	0.63
	CD7850S	No	P60	7.8	7.0	1.0	820	0.3	5.8
	DEP1349S	YES	P66	13.5	13.5	0.4	8.0	6.63	18.87
	KTDRH74S	YES	P51	7.8	7.8	1.0	1000	0.18	1.84
	KTNR1050S	YES	P19	10.0	10.0	1.0	33	1.8	6.3
	KTNR8050S	YES	P18	8.0	8.0	1.5	10000	0.09	6.0
5.2	SBF3316M	No	P64	12.95	9.4	1.0	3300	0.17	6.8
5.6	DEP1256H	YES	P66	12.5	12.5	0.9	10	5.60	18.2
5.7	CD1054S/H	No	P61	10.0	9.0	1.0	5600	0.2	8.0
	KTDRH125S	YES	P48	12.2	12.2	1.3	10000	0.12	8.0
5.8	MTA1260S	YES	P41	13.45	12.6	1.5	150	1.20	22.6
6.0	KTNR8060S	YES	P18	8.0	8.0	680	5000	0.18	0.46
6.2	CD7862H	No	P60	7.8	7.0	700	3000	0.3	0.68
6.5	KTNR8065S	YES	P18	8.0	8.0	8.2	10000	0.13	4.2
	MTA1265S	YES	P41	13.45	12.6	4.7	100	2.80	12.8
7.0	MTA1707S	YES	P42	17.15	17.15	2.2	100	2.96	23.2
7.1	SBF5022M	No	P65	15.24	12.7	1.0	1000	0.56	8.6
7.3	CD7870H	No	P61	7.8	7.0	700	5200	0.32	0.7
7.5	KTDRH127S	YES	P49	12.2	12.2	1.0	2200	0.3	9.8
9.5	KTDRH129S	YES	P50	12.2	12.2	1.0	1000	0.7	19.9
11.4	SBF3340M	No	P65	12.95	9.4	10	1000	0.1	3.57

Note: L:the length, W: the width

Product Outline

- Magnetic powder epoxy coating reduces buzz noise to a low level.
- A wide range of product line up is available to meet the various requirements.
- For DC/DC converter applications.
- Ideally used in the devices such as smartphone, car navigation, flat-screen TVs, smart screen, notebook PC, LED lighting, various power modules, etc.
- Custom design is also available.

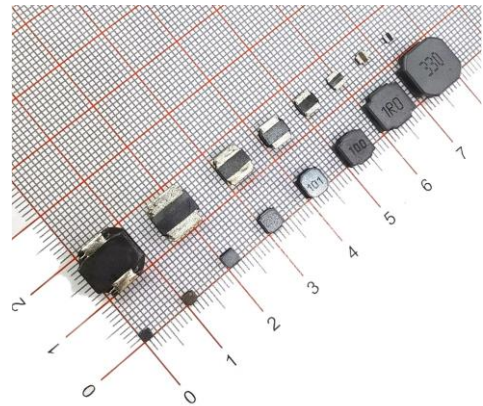

Dimensions(mm)

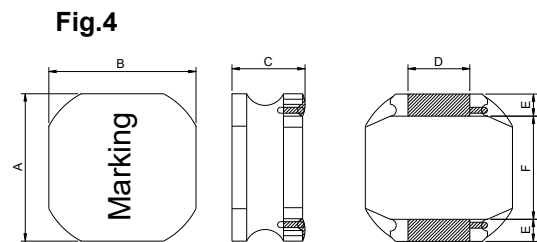
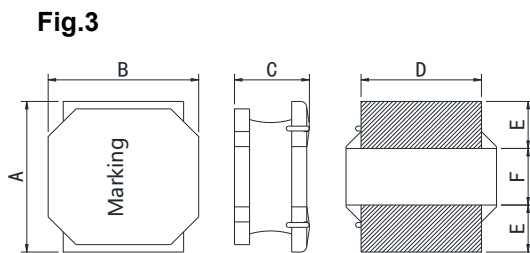
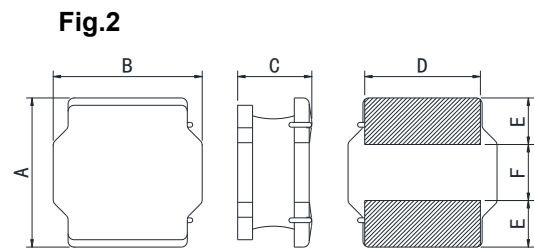
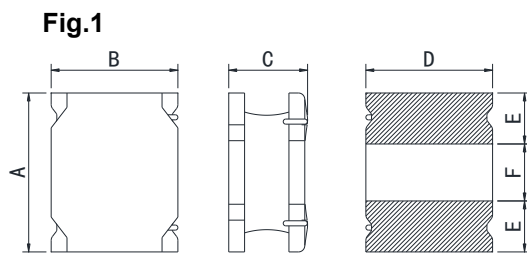

Recommended Patterns

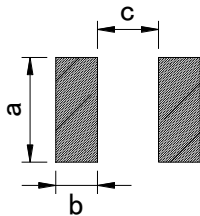

unit: mm

Type	Shape	A	B	C	D	E	F	a	b	c	Packaging (pcs/reel)
KTNR252010S	Fig.1	2.5±0.1	2.0±0.1	1.0 Max.	2.0±0.1	0.8	0.8	2.0	0.85	0.8	2000
KTNR252012S	Fig.1	2.5±0.1	2.0±0.1	1.2 Max.	2.0±0.1	0.8	0.8	2.0	0.85	0.8	2000
KTNR3012S	Fig.2	3.0±0.2	3.0±0.2	1.2 Max.	2.5±0.2	0.75	1.5	2.7	0.8	1.5	2000
KTNR3015S	Fig.2	3.0±0.2	3.0±0.2	1.5 Max.	2.5±0.2	0.75	1.5	2.7	0.8	1.5	2000
KTNR4012S	Fig.2	4.0±0.2	4.0±0.2	1.2 Max.	3.3±0.2	0.95	2.1	3.7	1.1	1.9	4500
KTNR4018S	Fig.2	4.0±0.2	4.0±0.2	1.8 Max.	3.3±0.2	0.95	2.1	3.7	1.1	1.9	3000
KTNR4020S	Fig.2	4.0±0.2	4.0±0.2	2.0 Max.	3.3±0.2	0.95	2.1	3.7	1.1	1.9	3000
KTNR4030S	Fig.2	4.0±0.2	4.0±0.2	3.0 Max.	3.3±0.2	0.95	2.1	3.7	1.1	1.9	2000
KTNR5020S	Fig.2	5.0±0.2	5.0±0.2	2.0 Max.	4.0±0.2	1.25	2.5	4.2	1.4	2.3	2500
KTNR5040S	Fig.2	5.0±0.2	5.0±0.2	4.0 Max.	4.0±0.2	1.25	2.5	4.2	1.4	2.3	1500
KTNR6012S	Fig.2	6.0±0.3	6.0±0.3	1.2 Max.	4.9±0.3	1.55	2.9	5.7	1.7	2.8	2500
KTNR6020S	Fig.2	6.0±0.3	6.0±0.3	2.0 Max.	4.9±0.3	1.55	2.9	5.7	1.7	2.8	2500
KTNR6028S	Fig.2	6.0±0.3	6.0±0.3	2.8 Max.	4.9±0.3	1.55	2.9	5.7	1.7	2.8	2000
KTNR6045S	Fig.2	6.0±0.3	6.0±0.3	4.5 Max.	4.9±0.3	1.55	2.9	5.7	1.7	2.8	1500
KTNR8040S	Fig.2	8.0±0.3	8.0±0.3	4.2 Max.	6.3±0.3	2.0	4.0	7.5	2.2	3.8	1000
KTNR8050S	Fig.2	8.0±0.3	8.0±0.3	5.0 Max.	6.3±0.3	2.0	4.0	7.5	2.2	3.8	1000
KTNR8060S	Fig.2	8.0±0.3	8.0±0.3	6.0 Max.	6.3±0.3	2.0	4.0	7.5	2.2	3.8	1000
KTNR8065S	Fig.3	8.0±0.3	8.0±0.3	6.5 Max.	6.3±0.3	2.0	4.0	7.5	2.2	3.8	800
KTNR1050S	Fig.4	10.0±0.3	10.0±0.3	5.0 Max.	4.2±0.3	2.9	6.4	5.5	2.0	6.2	800

Dimensions without tolerance are typical.

Product Identification

KTNR 6045 S - 4R7 M C S
 ① ② ③ ④ ⑤ ⑥ ⑦

- ① Product Series No.
- ② Dimension symbol:6045=6.0 x 4.5mm (L x H)
- ③ Internal control code.
- ④ Inductance value:100=10×10⁰ uH=10 uH 4R7=4.7uH,101=100Uh,102=1.0mH
- ⑤ Tolerance:K=±10%,M=±20%,N=±30%,P=±35%
- ⑥ Packing Style:C=Carrier Taping, B=Bulk.
- ⑦ Characteristic parameter level.

KTNR252010S Electrical Characteristics

Part Number	Inductance (uH) ①	Inductance tolerance	DCR ② (mΩ) Max.	I sat ③ (A) Max.	I sat ③ (A) typ.	I rms ④ (A) Max.	I rms ④ (A) typ.
KTNR252010S-R22NCS	0.22	±30%	36	3.60	4.40	3.00	3.50
KTNR252010S-R33NCS	0.33	±30%	48	3.50	4.30	2.40	2.76
KTNR252010S-R47NCS	0.47	±30%	56	2.50	3.35	2.35	2.56
KTNR252010S-R56NCS	0.56	±30%	72	2.90	3.20	2.00	2.18
KTNR252010S-R68NCS	0.68	±30%	74	2.20	2.75	2.00	2.18
KTNR252010S-1R0NCS	1.0	±30%	108	1.85	2.20	1.65	1.80
KTNR252010S-1R5NCS	1.5	±30%	182	1.80	2.10	1.30	1.42
KTNR252010S-2R2NCS	2.2	±30%	209	1.20	1.60	1.20	1.31
KTNR252010S-3R3MCS	3.3	±20%	328	1.05	1.30	0.90	0.98
KTNR252010S-4R7MCS	4.7	±20%	563	0.95	1.15	0.70	0.76
KTNR252010S-5R6MCS	5.6	±20%	563	0.80	0.95	0.73	0.80
KTNR252010S-6R8MCS	6.8	±20%	896	0.78	0.92	0.59	0.64
KTNR252010S-100MCS	10	±20%	1092	0.65	0.78	0.50	0.55
KTNR252010S-150MCS	15	±20%	1508	0.40	0.60	0.50	0.55
KTNR252010S-220MCS	22	±20%	1625	0.40	0.48	0.45	0.50

KTNR252012S Electrical Characteristics

Part Number	Inductance (uH) ①	Inductance tolerance	DCR ② (mΩ) Max.	I sat ③ (A) Max.	I sat ③ (A) typ.	I rms ④ (A) Max.	I rms ④ (A) typ.
KTNR252012S-R22NCS	0.22	±30%	47	6.10	6.50	2.20	2.57
KTNR252012S-R33NCS	0.33	±30%	47	4.00	5.00	2.20	2.57
KTNR252012S-R47NCS	0.47	±30%	61	3.82	4.27	2.15	2.34
KTNR252012S-R68NCS	0.68	±30%	74	3.28	3.68	1.95	2.13
KTNR252012S-1R0NCS	1.0	±30%	90	2.59	2.90	1.93	2.10
KTNR252012S-1R2NCS	1.2	±30%	129	2.38	2.67	1.46	1.59
KTNR252012S-1R5MCS	1.5	±20%	147	2.24	2.51	1.40	1.53
KTNR252012S-2R2MCS	2.2	±20%	216	1.85	2.07	1.15	1.25
KTNR252012S-2R7MCS	2.7	±20%	239	1.72	1.92	1.09	1.19
KTNR252012S-3R3MCS	3.3	±20%	264	1.61	1.80	1.04	1.13
KTNR252012S-3R6MCS	3.6	±20%	348	1.46	1.64	0.90	0.98
KTNR252012S-4R3MCS	4.3	±20%	375	1.37	1.53	0.87	0.95
KTNR252012S-4R7MCS	4.7	±20%	385	1.12	1.25	0.84	0.92
KTNR252012S-5R1MCS	5.1	±20%	500	1.23	1.37	0.75	0.82
KTNR252012S-5R6MCS	5.6	±20%	538	1.11	1.25	0.73	0.80
KTNR252012S-6R2MCS	6.2	±20%	542	1.03	1.18	0.73	0.80
KTNR252012S-6R8MCS	6.8	±20%	581	0.98	1.15	0.69	0.75
KTNR252012S-7R5MCS	7.5	±20%	611	0.97	1.08	0.68	0.74
KTNR252012S-8R2MCS	8.2	±20%	658	0.98	1.05	0.65	0.71
KTNR252012S-9R1MCS	9.1	±20%	685	0.91	1.02	0.62	0.68
KTNR252012S-100MCS	10	±20%	690	0.79	0.90	0.62	0.65
KTNR252012S-120MCS	12	±20%	1075	0.78	0.85	0.51	0.56
KTNR252012S-150MCS	15	±20%	1591	0.68	0.77	0.42	0.46
KTNR252012S-220MCS	22	±20%	1976	0.53	0.59	0.38	0.41

All specifications are subject to change without notice.

KTNR3012S Electrical Characteristics

Part Number	Inductance (uH) ①	Inductance tolerance	DCR ② (mΩ) Max.	I sat ③ (A) Max.	I sat ③ (A) typ.	I rms ④ (A) Max.	I rms ④ (A) typ.
KTNR3012S-1R0NCS	1.0	±30%	52	2.4	2.8	2.2	2.7
KTNR3012S-1R2NCS	1.2	±30%	59	2.2	2.5	2.1	2.3
KTNR3012S-1R5NCS	1.5	±30%	59	1.62	1.9	2.0	2.2
KTNR3012S-1R8NCS	1.8	±30%	82	1.3	1.8	1.65	1.8
KTNR3012S-2R2NCS	2.2	±30%	98	1.2	1.7	1.6	1.75
KTNR3012S-2R4NCS	2.4	±30%	88	1.15	1.5	1.55	1.65
KTNR3012S-2R7NCS	2.7	±30%	110	1.14	1.4	1.48	1.5
KTNR3012S-3R3MCS	3.3	±20%	130	1.05	1.3	1.36	1.45
KTNR3012S-3R6MCS	3.6	±20%	130	1.05	1.2	1.30	1.40
KTNR3012S-3R9MCS	3.9	±20%	189	1.0	1.15	1.24	1.35
KTNR3012S-4R7MCS	4.7	±20%	156	0.9	1.0	1.24	1.30
KTNR3012S-5R6MCS	5.6	±20%	226	0.8	0.95	1.13	1.24
KTNR3012S-6R8MCS	6.8	±20%	247	0.75	0.90	0.98	1.1
KTNR3012S-100MCS	10	±20%	345	0.6	0.88	0.83	0.9
KTNR3012S-120MCS	12	±20%	449	0.48	0.67	0.73	0.84
KTNR3012S-150MCS	15	±20%	468	0.45	0.62	0.71	0.77
KTNR3012S-180MCS	18	±20%	709	0.43	0.59	0.58	0.65
KTNR3012S-220MCS	22	±20%	839	0.42	0.52	0.53	0.59
KTNR3012S-270MCS	27	±20%	1131	0.35	0.48	0.47	0.51
KTNR3012S-330MCS	33	±20%	1138	0.36	0.46	0.46	0.50
KTNR3012S-360MCS	36	±20%	1235	0.34	0.44	0.44	0.48
KTNR3012S-390MCS	39	±20%	1729	0.3	0.39	0.37	0.41
KTNR3012S-470MCS	47	±20%	1885	0.27	0.35	0.35	0.40
KTNR3012S-560MCS	56	±20%	1794	0.26	0.33	0.28	0.38
KTNR3012S-680MCS	68	±20%	2171	0.24	0.29	0.33	0.36
KTNR3012S-820MCS	82	±20%	3302	0.17	0.27	0.27	0.31
KTNR3012S-101MCS	100	±20%	3718	0.21	0.23	0.25	0.29

KTNR3015S Electrical Characteristics

Part Number	Inductance (uH) ①	Inductance tolerance	DCR ② (mΩ) Max.	I sat ③ (A) Max.	I sat ③ (A) typ.	I rms ④ (A) Max.	I rms ④ (A) typ.
KTNR3015S-R50NCS	0.5	±30%	39	3.90	4.20	2.60	2.80
KTNR3015S-1R0NCS	1.0	±30%	39	2.50	2.80	2.35	2.50
KTNR3015S-1R2NCS	1.2	±30%	52	2.45	2.70	1.95	2.30
KTNR3015S-1R5NCS	1.5	±30%	65	2.35	2.60	1.70	2.20
KTNR3015S-2R2NCS	2.2	±30%	78	1.60	2.00	1.60	2.00
KTNR3015S-2R7NCS	2.7	±30%	98	1.52	1.90	1.43	1.90
KTNR3015S-3R3MCS	3.3	±20%	104	1.32	1.81	1.36	1.60
KTNR3015S-3R9MCS	3.9	±20%	137	1.20	1.40	1.20	1.50
KTNR3015S-4R7MCS	4.7	±20%	163	1.10	1.35	1.09	1.30
KTNR3015S-6R8MCS	6.8	±20%	260	0.85	1.10	0.85	1.10
KTNR3015S-100MCS	10	±20%	325	0.72	0.92	0.77	0.90
KTNR3015S-120MCS	12	±20%	416	0.70	0.90	0.68	0.89
KTNR3015S-150MCS	15	±20%	455	0.66	0.88	0.65	0.75
KTNR3015S-180MCS	18	±20%	559	0.56	0.72	0.59	0.72

All specifications are subject to change without notice.

KTNR3015S Electrical Characteristics

Part Number	Inductance (uH) ①	Inductance tolerance	DCR ② (mΩ) Max	I sat ③ (A) Max.	I sat ③ (A) typ.	I rms ④ (A) Max.	I rms ④ (A) typ.
KTNR3015S-220MCS	22	±20%	598	0.52	0.68	0.57	0.69
KTNR3015S-270MCS	27	±20%	949	0.48	0.56	0.45	0.56
KTNR3015S-330MCS	33	±20%	1066	0.44	0.53	0.43	0.51
KTNR3015S-390MCS	39	±20%	1294	0.41	0.55	0.39	0.44
KTNR3015S-430MCS	43	±20%	1378	0.37	0.43	0.37	0.48
KTNR3015S-470MCS	47	±20%	1625	0.35	0.43	0.35	0.44
KTNR3015S-560MCS	56	±20%	1664	0.33	0.42	0.34	0.41
KTNR3015S-620MCS	62	±20%	2093	0.30	0.40	0.30	0.41
KTNR3015S-680MCS	68	±20%	3510	0.28	0.37	0.23	0.31
KTNR3015S-101MCS	100	±20%	4043	0.23	0.25	0.21	0.25
KTNR3015S-151MCS	150	±20%	4940	0.18	0.22	0.19	0.23

KTNR4012S Electrical Characteristics

Part Number	Inductance (uH) ①	Inductance tolerance	DCR ② (mΩ) Max.	I sat ③ (A) Max.	I sat ③ (A) typ.	I rms ④ (A) Max.	I rms ④ (A) typ.
KTNR4012S-1R0NCS	1.0	±30%	65	2.90	3.20	1.65	2.50
KTNR4012S-1R2NCS	1.2	±30%	85	2.80	3.10	1.46	2.20
KTNR4012S-1R5NCS	1.5	±30%	85	2.45	2.70	1.40	2.20
KTNR4012S-1R8NCS	1.8	±30%	104	2.35	2.60	1.32	1.90
KTNR4012S-2R2NCS	2.2	±30%	104	2.00	2.40	1.30	1.90
KTNR4012S-2R7NCS	2.7	±30%	117	1.90	2.30	1.25	1.70
KTNR4012S-3R3NCS	3.3	±30%	143	1.72	2.10	1.12	1.60
KTNR4012S-3R6NCS	3.6	±30%	143	1.70	1.80	1.10	1.60
KTNR4012S-4R3NCS	4.3	±30%	182	1.58	1.70	1.00	1.50
KTNR4012S-4R7NCS	4.7	±30%	163	1.30	1.65	1.05	1.50
KTNR4012S-5R6NCS	5.6	±30%	182	1.20	1.60	1.00	1.20
KTNR4012S-6R8MCS	6.8	±20%	257	1.10	1.40	0.84	1.20
KTNR4012S-100MCS	10	±20%	345	0.90	1.10	0.77	1.00
KTNR4012S-120MCS	12	±20%	377	0.80	1.00	0.70	0.95
KTNR4012S-150MCS	15	±20%	442	0.70	0.80	0.64	0.85
KTNR4012S-180MCS	18	±20%	611	0.65	0.75	0.55	0.80
KTNR4012S-220MCS	22	±20%	763	0.60	0.70	0.49	0.75
KTNR4012S-270MCS	27	±20%	936	0.55	0.65	0.45	0.60
KTNR4012S-330MCS	33	±20%	1053	0.48	0.60	0.42	0.58
KTNR4012S-360MCS	36	±20%	1170	0.45	0.55	0.40	0.56
KTNR4012S-390MCS	39	±20%	1430	0.44	0.48	0.37	0.50
KTNR4012S-470MCS	47	±20%	1430	0.40	0.45	0.37	0.50
KTNR4012S-560MCS	56	±20%	1625	0.35	0.43	0.33	0.46
KTNR4012S-680MCS	68	±20%	2535	0.33	0.42	0.27	0.45
KTNR4012S-820MCS	82	±20%	2782	0.30	0.40	0.26	0.36
KTNR4012S-101MCS	100	±20%	2873	0.25	0.30	0.25	0.35

Note:

- ① Inductance tested at 100kHz, 1V using an Agilent/HP 4192A or equivalent.
- ② DCR measured on a micro-ohmmeter.
- ③ Isat: The DC current at which the inductance decreases by 30% of its initial value.
- ④ Irms: The DC current at which $\Delta t=40^{\circ}\text{C}$.

All specifications are subject to change without notice.

KTNR4018S Electrical Characteristics

Part Number	Inductance (uH) ①	Inductance tolerance	DCR ② (mΩ) Max	I sat ③ (A) Max.	I sat ③ (A) typ.	I rms ④ (A) Max.	I rms ④ (A) typ.
KTNR4018S-R47NCS	0.47	±30%	18	4.50	5.20	4.00	4.50
KTNR4018S-R68NCS	0.68	±30%	26	4.30	5.00	3.30	3.80
KTNR4018S-1R0NCS	1.0	±30%	33	4.20	4.50	2.00	3.30
KTNR4018S-1R5NCS	1.5	±30%	39	3.35	4.00	1.80	3.20
KTNR4018S-1R8NCS	1.8	±30%	44	3.00	3.40	2.00	2.80
KTNR4018S-2R2MCS	2.2	±20%	59	2.70	3.20	1.65	2.60
KTNR4018S-3R3MCS	3.3	±20%	91	2.45	2.90	1.23	2.10
KTNR4018S-4R7MCS	4.7	±20%	117	1.70	2.20	1.20	1.80
KTNR4018S-6R8MCS	6.8	±20%	143	1.45	2.00	1.06	1.50
KTNR4018S-100MCS	10	±20%	234	1.30	1.60	0.84	1.20
KTNR4018S-150MCS	15	±20%	325	0.94	1.10	0.65	1.00
KTNR4018S-220MCS	22	±20%	468	0.80	0.88	0.59	0.85
KTNR4018S-330MCS	33	±20%	689	0.56	0.75	0.49	0.72
KTNR4018S-470MCS	47	±20%	845	0.57	0.70	0.42	0.65
KTNR4018S-680MCS	68	±20%	1300	0.47	0.51	0.32	0.52
KTNR4018S-101MCS	100	±20%	2275	0.40	0.44	0.25	0.41
KTNR4018S-151MCS	150	±20%	3250	0.31	0.34	0.22	0.36
KTNR4018S-221MCS	220	±20%	5200	0.27	0.30	0.17	0.27

KTNR4020S Electrical Characteristics

Part Number	Inductance (uH) ①	Inductance tolerance	DCR ② (mΩ) Max	I sat ③ (A) Max.	I sat ③ (A) typ.	I rms ④ (A) Max.	I rms ④ (A) typ.
KTNR4020S-R24MCS	0.24	±20%	14	10.5	12.5	4.50	5.20
KTNR4020S-R33NCS	0.33	±30%	16	7.50	8.50	3.30	4.90
KTNR4020S-R47NCS	0.47	±30%	29	7.00	7.50	3.30	3.70
KTNR4020S-R68NCS	0.68	±30%	36	6.40	6.60	2.80	3.30
KTNR4020S-1R0NCS	1.0	±30%	38	4.78	5.20	2.15	3.20
KTNR4020S-1R2NCS	1.2	±30%	38	5.10	5.60	2.15	3.20
KTNR4020S-1R5NCS	1.5	±30%	46	4.45	4.90	1.98	3.00
KTNR4020S-2R2MCS	2.2	±20%	52	3.40	3.70	1.85	2.80
KTNR4020S-3R3MCS	3.3	±20%	91	3.10	3.50	1.40	2.50
KTNR4020S-3R6MCS	3.6	±20%	72	2.70	3.00	1.54	2.40
KTNR4020S-4R7MCS	4.7	±20%	98	2.35	2.50	1.34	2.00
KTNR4020S-5R1MCS	5.1	±20%	111	2.30	2.45	1.27	1.80
KTNR4020S-5R6MCS	5.6	±20%	117	2.20	2.40	1.22	1.80
KTNR4020S-6R2MCS	6.2	±20%	150	2.15	2.30	1.08	1.60
KTNR4020S-6R8MCS	6.8	±20%	163	2.00	2.20	1.04	1.60
KTNR4020S-7R5MCS	7.5	±20%	150	1.85	2.00	1.08	1.50
KTNR4020S-8R2MCS	8.2	±20%	163	1.75	1.90	1.04	1.40
KTNR4020S-100MCS	10	±20%	215	1.60	1.70	0.90	1.20
KTNR4020S-120MCS	12	±20%	228	1.50	1.60	0.88	1.20
KTNR4020S-150MCS	15	±20%	299	1.35	1.50	0.77	1.10
KTNR4020S-220MCS	22	±20%	455	1.05	1.10	0.62	0.87
KTNR4020S-270MCS	27	±20%	709	1.02	1.00	0.50	0.70
KTNR4020S-330MCS	33	±20%	715	0.85	0.93	0.49	0.68

All specifications are subject to change without notice.

KTNR4020S Electrical Characteristics

Part Number	Inductance (uH) ①	Inductance tolerance	DCR ② (mΩ) Max	I sat ③ (A) Max.	I sat ③ (A) typ.	I rms ④ (A) Max.	I rms ④ (A) typ.
KTNR4020S-390MCS	39	±20%	845	0.82	0.90	0.46	0.64
KTNR4020S-430MCS	43	±20%	858	0.77	0.85	0.45	0.63
KTNR4020S-470MCS	47	±20%	923	0.74	0.81	0.44	0.61
KTNR4020S-510MCS	51	±20%	975	0.70	0.77	0.42	0.59
KTNR4020S-560MCS	56	±20%	1040	0.66	0.72	0.41	0.57
KTNR4020S-620MCS	62	±20%	1170	0.65	0.71	0.39	0.52
KTNR4020S-680MCS	68	±20%	1380	0.61	0.67	0.36	0.50
KTNR4020S-750MCS	75	±20%	1510	0.58	0.65	0.35	0.49
KTNR4020S-820MCS	82	±20%	1520	0.50	0.55	0.34	0.47
KTNR4020S-101MCS	100	±20%	2020	0.48	0.53	0.31	0.43

KTNR4030S Electrical Characteristics

Part Number	Inductance (uH) ①	Inductance tolerance	DCR ② (mΩ) Max.	I sat ③ (A) Max.	I sat ③ (A) typ.	I rms ④ (A) Max.	I rms ④ (A) typ.
KTNR4030S-R47NCS	0.47	±30%	10	8.50	9.80	5.20	5.90
KTNR4030S-R56NCS	0.56	±30%	11	8.00	9.40	5.00	5.80
KTNR4030S-R68NCS	0.68	±30%	13	6.80	8.00	4.56	5.10
KTNR4030S-R91NCS	0.91	±30%	17	6.25	6.80	4.15	4.70
KTNR4030S-1R0NCS	1.0	±30%	18	6.00	6.50	4.15	4.70
KTNR4030S-1R2NCS	1.2	±30%	20	5.80	6.30	3.82	4.20
KTNR4030S-1R5NCS	1.5	±30%	26	5.20	5.80	3.34	3.60
KTNR4030S-1R8NCS	1.8	±30%	33	5.00	5.30	3.20	3.30
KTNR4030S-2R2NCS	2.2	±30%	39	4.50	5.00	2.95	3.20
KTNR4030S-3R3MCS	3.3	±20%	52	3.30	4.00	2.40	2.60
KTNR4030S-3R6MCS	3.6	±20%	52	3.05	3.60	2.40	2.60
KTNR4030S-3R9MCS	3.9	±20%	74	3.00	3.30	2.10	2.30
KTNR4030S-4R3MCS	4.3	±20%	74	2.95	3.20	2.10	2.30
KTNR4030S-4R7MCS	4.7	±20%	78	2.90	3.20	2.00	2.30
KTNR4030S-5R6MCS	5.6	±20%	85	2.60	2.80	1.95	2.10
KTNR4030S-6R2MCS	6.2	±20%	117	2.40	2.60	1.75	1.90
KTNR4030S-6R8MCS	6.8	±20%	117	2.00	2.20	1.65	1.80
KTNR4030S-7R5MCS	7.5	±20%	110	1.80	2.00	1.65	1.70
KTNR4030S-8R2MCS	8.2	±20%	117	1.70	1.90	1.60	1.65
KTNR4030S-100MCS	10	±20%	130	1.60	1.80	1.50	1.60
KTNR4030S-120MCS	12	±20%	175	1.50	1.70	1.30	1.40
KTNR4030S-150MCS	15	±20%	247	1.45	1.60	1.11	1.30
KTNR4030S-180MCS	18	±20%	260	1.40	1.50	1.10	1.25
KTNR4030S-220MCS	22	±20%	292	1.30	1.40	1.00	1.20
KTNR4030S-270MCS	27	±20%	338	1.15	1.35	0.90	1.05
KTNR4030S-330MCS	33	±20%	429	1.10	1.25	0.84	0.92
KTNR4030S-360MCS	36	±20%	436	1.05	1.18	0.83	0.91
KTNR4030S-390MCS	39	±20%	566	1.03	1.12	0.73	0.80
KTNR4030S-470MCS	47	±20%	579	0.95	1.08	0.72	0.80
KTNR4030S-510MCS	51	±20%	611	0.90	0.98	0.70	0.80
KTNR4030S-560MCS	56	±20%	722	0.85	0.94	0.65	0.71

All specifications are subject to change without notice.

KTNR4030S Electrical Characteristics

Part Number	Inductance (uH) ①	Inductance tolerance	DCR ② (mΩ) Max.	I sat ③ (A) Max.	I sat ③ (A) typ.	I rms ④ (A) Max.	I rms ④ (A) typ.
KTNR4030S-620MCS	62	±20%	761	0.80	0.99	0.63	0.68
KTNR4030S-680MCS	68	±20%	1128	0.72	0.80	0.52	0.57
KTNR4030S-750MCS	75	±20%	1326	0.70	0.78	0.48	0.53
KTNR4030S-820MCS	82	±20%	1378	0.66	0.73	0.47	0.52
KTNR4030S-910MCS	91	±20%	1430	0.65	0.71	0.46	0.50
KTNR4030S-101MCS	100	±20%	1495	0.60	0.68	0.45	0.49
KTNR4030S-121MCS	120	±20%	1755	0.55	0.60	0.41	0.47
KTNR4030S-151MCS	150	±20%	2340	0.50	0.55	0.38	0.44
KTNR4030S-221MCS	220	±20%	3250	0.40	0.50	0.35	0.40
KTNR4030S-331MCS	330	±20%	5200	0.32	0.40	0.20	0.26
KTNR4030S-471KCS	470	±10%	9360	0.30	0.35	0.19	0.23
KTNR4030S-501MCS	500	±20%	9027	0.26	0.30	0.16	0.20
KTNR4030S-681MCS	680	±20%	9854	0.18	0.20	0.14	0.18

KTNR5020S Electrical Characteristics

Part Number	Inductance (uH)①	Inductance tolerance	DCR ② (mΩ) Max	I sat ③ (A) max.	I sat ③ (A) typ.	I rms ④ (A) Max.	I rms ④ (A) typ.
KTNR5020S-R47NCS	0.47	±30%	17	6.20	6.70	4.60	5.00
KTNR5020S-R56NCS	0.56	±30%	22	6.00	6.50	4.20	4.50
KTNR5020S-R68NCS	0.68	±30%	22	5.50	6.00	4.00	4.40
KTNR5020S-R75NCS	0.75	±30%	22	5.30	5.80	4.00	4.40
KTNR5020S-1R0NCS	1.0	±30%	26	4.60	5.00	3.80	4.10
KTNR5020S-1R2NCS	1.2	±30%	29	4.50	4.90	3.55	3.90
KTNR5020S-1R5NCS	1.5	±30%	34	4.10	4.50	3.20	3.50
KTNR5020S-2R2NCS	2.2	±30%	42	3.20	4.00	2.90	3.10
KTNR5020S-2R7NCS	2.7	±30%	49	2.90	3.50	2.70	2.90
KTNR5020S-3R0NCS	3.0	±30%	49	2.70	3.30	2.70	2.90
KTNR5020S-3R3NCS	3.3	±30%	56	2.60	3.20	2.50	2.70
KTNR5020S-3R6NCS	3.6	±30%	56	2.40	3.00	2.50	2.70
KTNR5020S-3R9NCS	3.9	±30%	56	2.30	2.80	2.50	2.70
KTNR5020S-4R7MCS	4.7	±20%	74	2.20	2.70	2.20	2.40
KTNR5020S-5R6MCS	5.6	±20%	83	2.10	2.50	2.05	2.20
KTNR5020S-6R8MCS	6.8	±20%	108	2.00	2.20	1.80	1.90
KTNR5020S-7R5MCS	7.5	±20%	117	1.85	2.00	1.75	1.90
KTNR5020S-8R2MCS	8.2	±20%	127	1.75	1.90	1.65	1.80
KTNR5020S-100MCS	10	±20%	143	1.70	1.80	1.55	1.70
KTNR5020S-120MCS	12	±20%	182	1.50	1.60	1.40	1.50
KTNR5020S-150MCS	15	±20%	215	1.35	1.40	1.25	1.30
KTNR5020S-180MCS	18	±20%	260	1.25	1.30	1.15	1.20
KTNR5020S-220MCS	22	±20%	294	1.15	1.20	1.10	1.20
KTNR5020S-330MCS	33	±20%	507	0.92	1.00	0.90	0.99
KTNR5020S-470MCS	47	±20%	680	0.82	0.90	0.77	0.84
KTNR5020S-560MCS	56	±20%	819	0.75	0.84	0.70	0.77
KTNR5020S-680MCS	68	±20%	962	0.68	0.70	0.64	0.70
KTNR5020S-820MCS	82	±20%	1158	0.65	0.75	0.50	0.60
KTNR5020S-101MCS	100	±20%	1430	0.53	0.58	0.53	0.58
KTNR5020S-121MCS	120	±20%	1755	0.42	0.53	0.40	0.50

All specifications are subject to change without notice.

KTNR5040S Electrical Characteristics

Part Number	Inductance (uH) ①	Inductance tolerance	DCR ② (mΩ) Max.	I sat ③ (A) Max.	I sat ③ (A) typ.	I rms ④ (A) Max.	I rms ④ (A) typ.
KTNR5040S-R22NCS	0.22	±30%	8.0	18.0	20.0	6.50	7.50
KTNR5040S-R24NCS	0.24	±30%	8.0	15.7	18.0	6.40	7.40
KTNR5040S-R47NCS	0.47	±30%	9.0	10.0	11.5	6.60	7.60
KTNR5040S-1R0NCS	1.0	±30%	16	7.35	8.20	4.90	5.10
KTNR5040S-1R5NCS	1.5	±30%	20	6.30	7.30	4.30	4.80
KTNR5040S-2R2NCS	2.2	±30%	25	4.90	5.60	3.80	4.30
KTNR5040S-2R7NCS	2.7	±30%	29	4.30	5.10	3.60	4.10
KTNR5040S-3R0NCS	3.0	±30%	29	4.15	4.80	3.60	4.20
KTNR5040S-3R3NCS	3.3	±30%	31	3.95	4.60	3.40	3.90
KTNR5040S-4R7MCS	4.7	±20%	39	3.50	3.90	3.00	3.30
KTNR5040S-5R6MCS	5.6	±20%	46	3.00	4.10	2.80	3.10
KTNR5040S-6R8MCS	6.8	±20%	56	2.90	3.50	2.50	2.80
KTNR5040S-8R2MCS	8.2	±20%	62	2.70	3.00	2.30	2.60
KTNR5040S-100MCS	10	±20%	83	2.35	2.90	2.10	2.40
KTNR5040S-120MCS	12	±20%	100	2.20	2.50	2.00	2.10
KTNR5040S-150MCS	15	±20%	112	2.00	2.30	2.00	2.10
KTNR5040S-180MCS	18	±20%	155	1.70	2.00	1.45	1.65
KTNR5040S-220MCS	22	±20%	168	1.60	1.90	1.50	1.60
KTNR5040S-270MCS	27	±20%	244	1.52	1.75	1.10	1.25
KTNR5040S-330MCS	33	±20%	244	1.30	1.50	1.20	1.40
KTNR5040S-470MCS	47	±20%	354	1.10	1.30	1.00	1.10
KTNR5040S-510MCS	51	±20%	494	1.00	1.20	1.00	1.10
KTNR5040S-560MCS	56	±20%	494	1.05	1.20	0.80	0.90
KTNR5040S-680MCS	68	±20%	520	0.90	1.10	0.80	0.90
KTNR5040S-750MCS	75	±20%	585	0.85	0.95	0.72	0.80
KTNR5040S-101MCS	100	±20%	728	0.75	0.90	0.70	0.80
KTNR5040S-151MCS	150	±20%	975	0.65	0.67	0.60	0.70
KTNR5040S-221MCS	220	±20%	1820	0.48	0.55	0.40	0.50
KTNR5040S-301MCS	300	±20%	2600	0.50	0.58	0.35	0.40
KTNR5040S-331MCS	330	±20%	2730	0.42	0.47	0.40	0.50
KTNR5040S-471MCS	470	±20%	3900	0.37	0.43	0.35	0.40
KTNR5040S-561MCS	560	±20%	4914	0.31	0.36	0.31	0.35
KTNR5040S-681MCS	680	±20%	5070	0.30	0.35	0.25	0.30
KTNR5040S-102MCS	1000	±20%	7800	0.21	0.25	0.20	0.23
KTNR5040S-152MCS	1500	±20%	10582	0.20	0.23	0.19	0.22
KTNR5040S-202MCS	2000	±20%	14760	0.17	0.20	0.14	0.16
KTNR5040S-332MCS	3300	±20%	25200	0.14	0.16	0.10	0.12
KTNR5040S-392MCS	3900	±20%	30550	0.125	0.15	0.10	0.115
KTNR5040S-472MCS	4700	±20%	45500	0.12	0.14	0.08	0.10
KTNR5040S-502MCS	5000	±20%	43160	0.11	0.13	0.085	0.098
KTNR5040S-562MCS	5600	±20%	50700	0.105	0.12	0.08	0.092
KTNR5040S-682MCS	6800	±20%	55900	0.09	0.11	0.075	0.086
KTNR5040S-822MCS	8200	±20%	55900	0.07	0.085	0.075	0.086
KTNR5040S-103MCS	10000	±20%	58500	0.065	0.075	0.075	0.086

All specifications are subject to change without notice.

KTNR6012S Electrical Characteristics

Part Number	Inductance (uH) ①	Inductance tolerance	DCR ② (mΩ) Max.	I sat ③ (A) max.	I sat ③ (A) typ.	I rms ④ (A) max.	I rms ④ (A) typ.
KTNR6012S-1R0NCS	1.00	±30%	55	3.12	3.52	2.09	2.30
KTNR6012S-1R5NCS	1.50	±30%	75	2.42	2.73	1.82	2.00
KTNR6012S-2R5NCS	2.5	±30%	90	1.86	2.10	1.63	1.80
KTNR6012S-3R3NCS	3.3	±30%	105	1.59	1.80	1.54	1.70
KTNR6012S-4R7NCS	4.7	±30%	125	1.42	1.60	1.41	1.55
KTNR6012S-5R3NCS	5.3	±30%	125	1.33	1.50	1.35	1.5
KTNR6012S-6R8NCS	6.8	±30%	165	1.15	1.30	1.23	1.35
KTNR6012S-100MCS	10	±20%	200	0.89	1.00	1.09	1.20
KTNR6012S-150MCS	15	±20%	295	0.72	0.82	0.73	0.80
KTNR6012S-220MCS	22	±20%	465	0.67	0.76	0.59	0.65
KTNR6012S-330MCS	33	±20%	580	0.52	0.59	0.50	0.55
KTNR6012S-470MCS	47	±20%	810	0.46	0.52	0.42	0.46
KTNR6012S-680MCS	68	±20%	1160	0.39	0.44	0.37	0.41
KTNR6012S-101MCS	100	±20%	1670	0.31	0.35	0.29	0.32

KTNR6020S Electrical Characteristics

Part Number	Inductance (uH) ①	Inductance tolerance	DCR ② (mΩ) Max	I sat ③ (A) max.	I sat ③ (A) typ.	I rms ④ (A) Max.	I rms ④ (A) typ.
KTNR6020S-1R5NCS	1.5	±30%	29	4.30	5.10	3.20	4.00
KTNR6020S-1R8NCS	1.8	±30%	35	4.15	5.00	2.90	3.50
KTNR6020S-2R0NCS	2.0	±30%	36	4.10	4.80	2.80	3.40
KTNR6020S-2R2NCS	2.2	±30%	40	3.90	4.60	2.70	3.30
KTNR6020S-2R7NCS	2.7	±30%	46	3.70	4.50	2.60	3.20
KTNR6020S-3R3NCS	3.3	±30%	48	3.50	3.80	2.50	3.10
KTNR6020S-3R9NCS	3.9	±30%	64	3.25	3.70	2.30	2.80
KTNR6020S-4R3NCS	4.3	±30%	66	2.70	3.30	2.20	2.60
KTNR6020S-4R7NCS	4.7	±30%	75	2.60	3.00	2.00	2.50
KTNR6020S-5R6NCS	5.6	±30%	77	2.40	2.90	1.90	2.40
KTNR6020S-6R2NCS	6.2	±30%	100	2.30	2.70	1.80	2.30
KTNR6020S-6R8NCS	6.8	±30%	103	2.20	2.60	1.70	2.20
KTNR6020S-8R2NCS	8.2	±30%	135	2.10	2.50	1.50	1.90
KTNR6020S-100MCS	10	±20%	137	1.75	2.10	1.40	1.80
KTNR6020S-120MCS	12	±20%	156	1.45	1.70	1.30	1.60
KTNR6020S-150MCS	15	±20%	189	1.25	1.45	1.20	1.50
KTNR6020S-180MCS	18	±20%	234	1.15	1.30	1.08	1.40
KTNR6020S-220MCS	22	±20%	256	1.05	1.20	1.00	1.30
KTNR6020S-330MCS	33	±20%	390	0.95	1.10	0.84	1.05
KTNR6020S-470MCS	47	±20%	559	0.70	0.90	0.80	0.90
KTNR6020S-680MCS	68	±20%	820	0.65	0.75	0.75	0.86
KTNR6020S-101MCS	100	±20%	1200	0.55	0.65	0.50	0.58
KTNR6020S-151MCS	150	±20%	2080	0.50	0.60	0.45	0.52
KTNR6020S-221MCS	220	±20%	3460	0.45	0.55	0.35	0.41
KTNR6020S-331MCS	330	±20%	3419	0.27	0.33	0.33	0.39

All specifications are subject to change without notice.

KTNR6028S Electrical Characteristics

Part Number	Inductanc ^① (uH)	Inductance tolerance	DCR ^② (mΩ) Max.	I sat ^③ (A) Max.	I sat ^③ (A) typ.	I rms ^④ (A) Max.	I rms ^④ (A) typ.
KTNR6028S-R82NCS	0.82	±30%	12	7.80	9.00	5.20	6.00
KTNR6028S-1R0NCS	1.0	±30%	13	7.00	8.00	5.10	5.70
KTNR6028S-1R2NCS	1.2	±30%	17	6.40	7.50	4.70	5.20
KTNR6028S-1R5NCS	1.5	±30%	17	6.00	6.60	4.58	5.00
KTNR6028S-2R2NCS	2.2	±30%	26	5.10	5.60	3.75	4.10
KTNR6028S-2R7NCS	2.7	±30%	26	4.50	5.00	3.68	4.00
KTNR6028S-3R3NCS	3.3	±30%	33	4.15	4.50	3.48	3.80
KTNR6028S-4R7NCS	4.7	±30%	39	3.50	3.80	3.08	3.40
KTNR6028S-5R1NCS	5.1	±30%	56	3.20	3.50	2.60	2.80
KTNR6028S-6R2MCS	6.2	±20%	61	3.00	3.30	2.40	2.65
KTNR6028S-6R8MCS	6.8	±20%	61	2.60	3.00	2.35	2.60
KTNR6028S-8R2MCS	8.2	±20%	72	2.30	2.50	2.25	2.50
KTNR6028S-9R1MCS	9.1	±20%	96	2.10	2.40	2.15	2.45
KTNR6028S-100MCS	10	±20%	94	2.05	2.30	1.95	2.40
KTNR6028S-120MCS	12	±20%	104	1.80	2.00	1.85	2.00
KTNR6028S-150MCS	15	±20%	163	1.75	1.90	1.55	1.70
KTNR6028S-180MCS	18	±20%	156	1.52	1.80	1.45	1.60
KTNR6028S-220MCS	22	±20%	182	1.45	1.70	1.40	1.55
KTNR6028S-270MCS	27	±20%	202	1.4	1.60	1.32	1.40
KTNR6028S-330MCS	33	±20%	241	1.35	1.50	1.22	1.30
KTNR6028S-360MCS	36	±20%	280	1.25	1.45	1.13	1.20
KTNR6028S-390MCS	39	±20%	293	1.20	1.40	1.10	1.15
KTNR6028S-470MCS	47	±20%	410	1.15	1.30	1.06	1.10
KTNR6028S-560MCS	56	±20%	449	1.05	1.20	0.89	1.00
KTNR6028S-680MCS	68	±20%	468	0.90	1.00	0.86	0.95
KTNR6028S-750MCS	75	±20%	533	0.80	0.95	0.81	0.90
KTNR6028S-820MCS	82	±20%	650	0.75	0.88	0.75	0.85
KTNR6028S-101MCS	100	±20%	650	0.65	0.71	0.70	0.77
KTNR6028S-401MCS	400	±20%	2808	0.30	0.33	0.40	0.45
KTNR6028S-102MCS	1000	±20%	7540	0.18	0.22	0.23	0.26

Note:

- ① Inductance tested at 100kHz, 1V using an Agilent/HP 4192A or equivalent.
- ② DCR measured on a micro-ohmmeter.
- ③ Isat: The DC current at which the inductance decreases by 30% of it' s initial value.
- ④ Irms: The DC current at which Δt=40℃.

KTNR6045S Electrical Characteristics

Part Number	Inductance (μ H) ①	Inductance tolerance	DCR ② (m Ω) Max.	I sat ③ (A) Max.	I sat ③ (A) typ.	I rms ④ (A) Max.	I rms ④ (A) typ.
KTNR6045S-R47NCS	0.47	±30%	8	15.00	16.50	6.8	7.8
KTNR6045S-R56NCS	0.56	±30%	8	14.00	15.00	6.5	7.5
KTNR6045S-R68NCS	0.68	±30%	8	11.00	12.00	5.8	6.5
KTNR6045S-R82NCS	0.82	±30%	10	10.35	11.00	5.7	6.0
KTNR6045S-1R0NCS	1.0	±30%	14	9.85	10.00	5.4	5.8
KTNR6045S-1R2NCS	1.2	±30%	13	9.0	9.70	5.2	5.5
KTNR6045S-1R5NCS	1.5	±30%	16	8.5	9.0	4.9	5.40
KTNR6045S-1R8NCS	1.8	±30%	16	7.60	8.40	4.8	5.30
KTNR6045S-2R2NCS	2.2	±30%	18	6.75	7.40	4.6	5.00
KTNR6045S-2R7NCS	2.7	±30%	20	5.95	6.30	4.3	4.7
KTNR6045S-3R3NCS	3.3	±30%	27	5.80	6.20	3.8	4.2
KTNR6045S-3R6NCS	3.6	±30%	27	5.25	5.70	3.7	4.0
KTNR6045S-4R5MCS	4.5	±20%	34	5.00	5.60	3.4	3.7
KTNR6045S-4R7MCS	4.7	±20%	34	4.90	5.50	3.3	3.6
KTNR6045S-5R1MCS	5.1	±20%	34	4.40	4.80	3.2	3.5
KTNR6045S-5R6MCS	5.6	±20%	38	4.15	4.60	3.15	3.4
KTNR6045S-6R8MCS	6.8	±20%	40	3.90	4.30	2.9	3.3
KTNR6045S-8R2MCS	8.2	±20%	56	3.80	4.20	2.6	2.8
KTNR6045S-100MCS	10	±20%	62	3.20	3.50	2.45	2.7
KTNR6045S-120MCS	12	±20%	75	2.80	3.00	2.20	2.4
KTNR6045S-150MCS	15	±20%	88	2.50	2.70	2.05	2.2
KTNR6045S-180MCS	18	±20%	105	2.20	2.40	1.85	2.1
KTNR6045S-220MCS	22	±20%	116	2.05	2.20	1.80	2.0
KTNR6045S-270MCS	27	±20%	133	1.90	2.10	1.65	1.8
KTNR6045S-300MCS	30	±20%	172	1.70	1.85	1.50	1.65
KTNR6045S-330MCS	33	±20%	178	1.65	1.80	1.45	1.6
KTNR6045S-360MCS	36	±20%	225	1.62	1.75	1.40	1.5
KTNR6045S-390MCS	39	±20%	234	1.50	1.60	1.35	1.4
KTNR6045S-430MCS	43	±20%	260	1.45	1.55	1.25	1.35
KTNR6045S-470MCS	47	±20%	260	1.40	1.50	1.20	1.3
KTNR6045S-510MCS	51	±20%	269	1.3	1.40	1.15	1.2
KTNR6045S-560MCS	56	±20%	287	1.25	1.38	1.10	1.15
KTNR6045S-620MCS	62	±20%	306	1.15	1.35	1.05	1.10
KTNR6045S-680MCS	68	±20%	376	1.1	1.30	1.00	1.05
KTNR6045S-750MCS	75	±20%	397	1.05	1.20	0.95	1.00
KTNR6045S-820MCS	82	±20%	443	1.0	1.10	0.90	0.99
KTNR6045S-101MCS	100	±20%	563	0.90	1.00	0.80	0.86
KTNR6045S-121MCS	120	±20%	629	0.85	0.94	0.77	0.84
KTNR6045S-151MCS	150	±20%	754	0.80	0.88	0.70	0.75
KTNR6045S-221MCS	220	±20%	1084	0.70	0.77	0.59	0.65
KTNR6045S-331MCS	330	±20%	1651	0.57	0.63	0.57	0.63
KTNR6045S-471MCS	470	±20%	2340	0.50	0.56	0.42	0.48
KTNR6045S-681MCS	680	±20%	3250	0.42	0.46	0.33	0.38
KTNR6045S-102MCS	1000	±20%	5850	0.30	0.35	0.30	0.35
KTNR6045S-152MCS	1500	±20%	8450	0.24	0.27	0.21	0.24

All specifications are subject to change without notice.

KTNR8040S Electrical Characteristics

Part Number	Inductance (μ H) ①	Inductance tolerance	DCR ② (m Ω) Max.	I sat ③ (A) Max.	I sat ③ (A) typ.	I rms ④ (A) Max.	I rms ④ (A) typ.
KTNR8040S-R82NCS	0.82	±30%	10	13.5	15.0	6.50	7.00
KTNR8040S-1R0NCS	1.0	±30%	10	12.0	14.0	6.30	6.80
KTNR8040S-1R2NCS	1.2	±30%	13	11.5	13.5	5.75	6.30
KTNR8040S-1R5NCS	1.5	±30%	13	9.8	11.0	5.65	6.20
KTNR8040S-2R0NCS	2.0	±30%	16	8.8	10.0	5.25	5.70
KTNR8040S-2R2NCS	2.2	±30%	16	7.10	8.00	5.15	5.60
KTNR8040S-3R0NCS	3.0	±30%	18	6.10	7.3	4.70	5.20
KTNR8040S-3R3NCS	3.3	±30%	22	6.50	7.0	4.50	4.90
KTNR8040S-3R6MCS	3.6	±20%	22	6.2	6.80	4.4	4.80
KTNR8040S-3R9NCS	3.9	±30%	22	5.75	6.50	4.35	4.70
KTNR8040S-4R7NCS	4.7	±30%	25	5.72	6.20	4.10	4.50
KTNR8040S-5R6NCS	5.6	±30%	27	5.70	6.00	3.85	4.20
KTNR8040S-6R2NCS	6.2	±30%	27	4.45	5.10	3.70	4.10
KTNR8040S-6R8MCS	6.8	±20%	31	4.35	5.00	3.60	4.00
KTNR8040S-8R2MCS	8.2	±20%	34	4.20	4.80	3.45	3.80
KTNR8040S-100MCS	10	±20%	38	3.60	4.10	3.30	3.60
KTNR8040S-120MCS	12	±20%	53	3.50	4.00	2.80	3.00
KTNR8040S-150MCS	15	±20%	61	2.95	3.40	2.60	2.80
KTNR8040S-180MCS	18	±20%	69	2.70	3.10	2.40	2.60
KTNR8040S-220MCS	22	±20%	90	2.40	2.70	2.10	2.30
KTNR8040S-270MCS	27	±20%	101	2.15	2.50	2.00	2.20
KTNR8040S-330MCS	33	±20%	126	2.05	2.40	1.80	2.00
KTNR8040S-360MCS	36	±20%	133	2.00	2.30	1.75	1.90
KTNR8040S-390MCS	39	±20%	139	1.95	2.20	1.70	1.85
KTNR8040S-430MCS	43	±20%	147	1.90	2.15	1.65	1.80
KTNR8040S-470MCS	47	±20%	177	1.75	2.00	1.55	1.70
KTNR8040S-510MCS	51	±20%	185	1.70	1.90	1.50	1.60
KTNR8040S-560MCS	56	±20%	192	1.55	1.70	1.45	1.55
KTNR8040S-620MCS	62	±20%	237	1.50	1.65	1.30	1.40
KTNR8040S-680MCS	68	±20%	255	1.45	1.60	1.25	1.35
KTNR8040S-750MCS	75	±20%	274	1.35	1.50	1.20	1.30
KTNR8040S-820MCS	82	±20%	293	1.30	1.40	1.15	1.20
KTNR8040S-910MCS	91	±20%	354	1.20	1.30	1.05	1.10
KTNR8040S-101MCS	100	±20%	377	1.15	1.25	1.00	1.05
KTNR8040S-121MCS	120	±20%	434	1.05	1.10	0.95	1.00
KTNR8040S-151MCS	150	±20%	533	0.95	1.05	0.85	0.94
KTNR8040S-181MCS	180	±20%	676	0.90	1.0	0.83	0.92
KTNR8040S-221MCS	220	±20%	779	0.85	0.94	0.80	0.88
KTNR8040S-331MCS	330	±20%	1156	0.68	0.75	0.64	0.70
KTNR8040S-471MCS	470	±20%	1625	0.60	0.70	0.50	0.60
KTNR8040S-561MCS	560	±20%	2327	0.55	0.65	0.47	0.54
KTNR8040S-681MCS	680	±20%	2652	0.53	0.60	0.45	0.50
KTNR8040S-821MCS	820	±20%	3640	0.48	0.55	0.35	0.40
KTNR8040S-102MCS	1000	±20%	3640	0.40	0.50	0.35	0.40
KTNR8040S-152MCS	1500	±20%	6500	0.32	0.38	0.26	0.27

All specifications are subject to change without notice.

KTNR8050S Electrical Characteristics

Part Number	Inductance (uH) ①	Inductance tolerance	DCR ② (mΩ) Max	I sat ③ (A) typ.	I sat ③ (A) typ.	I rms ④ (A) Max.	I rms ④ (A) typ.
KTNR8050S-1R5MCS	1.5	±20%	12.00	10	12.0	6.00	6.40
KTNR8050S-102MCS	1000	±20%	2520	0.78	0.90	0.32	0.37
KTNR8050S-122KCS	1200	±10%	5400	0.70	0.80	0.30	0.35
KTNR8050S-152KCS	1500	±10%	5010	0.60	0.70	0.29	0.33
KTNR8050S-103MCS*	10000	±20%	22800	0.09	0.10	0.11	0.13

*The test frequency of KTNR8050S-103MCS is 1kHz.

KTNR8060S Electrical Characteristics

Part Number	Inductance (uH) ①	Inductance tolerance	DCR ② (mΩ)Max	I sat ③ (A) typ.	I sat ③ (A) typ.	I rms ④ (A) Max.	I rms ④ (A) typ.
KTNR8060S-681KCS	680	±10%	2170	0.72	0.82	0.46	0.53
KTNR8060S-162KCS	1600	±10%	4500	0.47	0.55	0.33	0.38
KTNR8060S-202KCS	2000	±10%	5800	0.43	0.50	0.28	0.32
KTNR8060S-222KCS	2200	±10%	6880	0.42	0.49	0.26	0.30
KTNR8060S-502KCS	5000	±10%	14900	0.27	0.31	0.18	0.21

KTNR8065S Electrical Characteristics

Part Number	Inductance (uH) ①	Inductance tolerance	DCR ② (mΩ) Max.	I sat ③ (A) Max.	I sat ③ (A) typ.	I rms ④ (A) Max.	I rms ④ (A) typ.
KTNR8065S-8R2MCS	8.2	±20%	31	7.0	7.8	4.2	4.8
KTNR8065S-100MCS	10	±20%	44	6.2	7.1	3.5	3.8
KTNR8065S-150MCS	15	±20%	53	5.8	6.7	3.3	3.6
KTNR8065S-220MCS	22	±20%	72	4.3	4.8	2.7	3.1
KTNR8065S-470MCS	47	±20%	152	3.4	4.0	1.85	2.15
KTNR8065S-560MCS	56	±20%	198	3.2	3.7	1.55	1.85
KTNR8065S-680MCS	68	±20%	218	2.7	3.2	1.35	1.6
KTNR8065S-101MCS	100	±20%	280	2.0	2.4	1.25	1.45
KTNR8065S-151MCS	150	±20%	440	1.6	2.0	0.95	1.1
KTNR8065S-221MCS	220	±20%	656	1.25	1.5	0.8	0.9
KTNR8065S-331MCS	330	±20%	840	1.15	1.3	0.75	0.85
KTNR8065S-471MCS	470	±20%	1560	1.0	1.2	0.55	0.65
KTNR8065S-681MCS	680	±20%	1944	0.85	1.0	0.52	0.6
KTNR8065S-102MCS	1000	±20%	2820	0.65	0.73	0.4	0.45
KTNR8065S-152MCS	1500	±20%	4380	0.54	0.6	0.32	0.37
KTNR8065S-222MCS	2200	±20%	6000	0.45	0.5	0.27	0.31
KTNR8065S-332MCS	3300	±20%	8760	0.36	0.4	0.23	0.26
KTNR8065S-472MCS	4700	±20%	14580	0.29	0.33	0.18	0.2
KTNR8065S-682MCS	6800	±20%	22440	0.26	0.29	0.14	0.16
KTNR8065S-103MCS	10000	±20%	27360	0.2	0.23	0.13	0.15

Note:

- ① Inductance tested at 100kHz, 1V using an Agilent/HP 4192A or equivalent.
- ② DCR measured on a micro-ohmmeter.
- ③ Isat: The DC current at which the inductance decreases by 30% of its initial value.
- ④ Irms: The DC current at which $\Delta t=40^{\circ}\text{C}$.

All specifications are subject to change without notice.

KTNR1050S Electrical Characteristics

Part Number	Inductance (uH) ①	Inductance tolerance	DCR ② (mΩ) Max.	I sat ③ (A) Max.	I sat ③ (A) typ.	I rms ④ (A) Max.	I rms ④ (A) typ.
KTNR1050S-1R0NCS	1.0	±30%	18	12.5	14	6.3	6.9
KTNR1050S-1R2NCS	1.2	±30%	20	11.5	13.8	5.85	6.3
KTNR1050S-1R5NCS	1.5	±30%	21	9.8	12.5	5.65	6.2
KTNR1050S-2R2NCS	2.2	±30%	25	9.5	12	5.2	5.6
KTNR1050S-3R3NCS	3.3	±30%	27	9.0	11	4.4	4.8
KTNR1050S-4R7NCS	4.7	±30%	30	8.5	10.5	4.0	4.5
KTNR1050S-6R8MCS	6.8	±20%	36	7.5	9.0	3.6	4.0
KTNR1050S-8R2MCS	8.2	±20%	40	6.8	7.8	3.4	3.8
KTNR1050S-100MCS	10	±20%	48	6.2	7.0	3.3	3.6
KTNR1050S-120MCS	12	±20%	53	5.8	6.5	2.8	3.2
KTNR1050S-150MCS	15	±20%	59	5.3	6.0	2.5	2.9
KTNR1050S-180MCS	18	±20%	69	4.5	5.0	2.4	2.7
KTNR1050S-220MCS	22	±20%	85	3.8	4.3	2.3	2.6
KTNR1050S-270MCS	27	±20%	105	3.5	4.0	2.2	2.4
KTNR1050S-330MCS	33	±20%	118	3.1	3.6	2.0	2.2
KTNR1050S-470MCS	47	±20%	160	2.8	3.3	1.75	1.9
KTNR1050S-680MCS	68	±20%	234	2.7	3.2	1.55	1.7
KTNR1050S-101MCS	100	±20%	335	2.15	2.5	1.25	1.4
KTNR1050S-221MCS	220	±20%	675	1.4	1.8	0.9	1.0
KTNR1050S-471MCS	470	±20%	1430	1.15	1.35	0.7	0.75
KTNR1050S-681MCS	680	±20%	1980	0.85	1.0	0.64	0.68
KTNR1050S-102MCS	1000	±20%	3425	0.76	0.85	0.5	0.55

Note:

- ① Inductance tested at 100kHz, 1V using an Agilent/HP 4192A or equivalent.
- ② DCR measured on a micro-ohmmeter.
- ③ Isat: The DC current at which the inductance decreases by 30% of its initial value.
- ④ Irms: The DC current at which $\Delta t=40^{\circ}\text{C}$.

Product Outline

- Magnetic powder epoxy coating reduces buzz noise to a low level(Alloy Powder Series).
- A wide range of product line up is available to meet the various requirements.
- For DC/DC converter applications.
- Ideally used in the devices such as smartphone, car navigation, smart screen, flat-screen TVs, notebook PC, LED lighting, various power modules, etc.
- Custom design is also available.

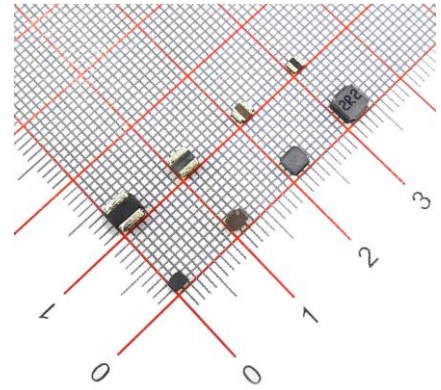

Dimensions(mm)

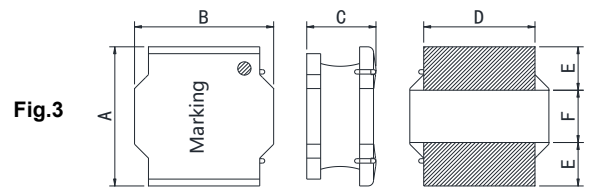
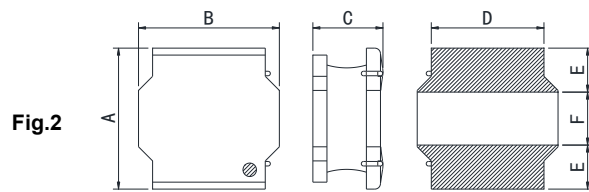
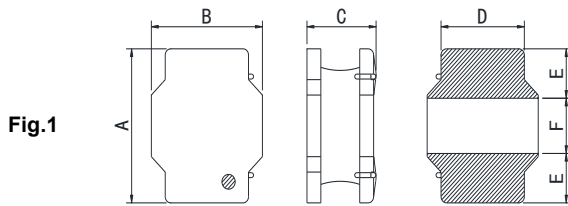

Recommended Patterns

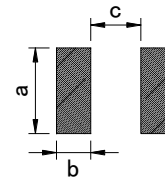

Type	Shape	A	B	C	D	E	F	a	b	c	Packaging (pcs/reel)
KTNR201610A	Fig.1	2.0±0.2	1.6±0.2	1.0 Max.	1.5±0.2	0.6	0.8	1.7	0.7	0.7	2000
KTNR252010A	Fig.1	2.5±0.2	2.0±0.2	1.0 Max.	1.65±0.2	0.8	0.8	2.0	0.85	0.8	2000
KTNR252012A	Fig.1	2.5±0.2	2.0±0.2	1.2 Max.	1.65±0.2	0.8	0.8	2.0	0.85	0.8	2000
KTNR3012A	Fig.2	3.0±0.2	3.0±0.2	1.2 Max.	2.6±0.2	0.75	1.5	3.2	0.8	1.5	2000
KTNR4012A	Fig.3	4.0±0.2	4.0±0.2	1.2 Max.	3.1±0.2	0.95	2.1	3.7	1.1	1.9	4500
KTNR4020A	Fig.3	4.0±0.2	4.0±0.2	2.0 Max.	3.4±0.2	0.95	2.1	3.7	1.1	1.9	3000

Dimensions without tolerance are typical.

Product Identification

KTNR **3012** **A** - **4R7** **M** **C** **S**
 ① ② ③ ④ ⑤ ⑥ ⑦

- ① Product Series No
- ② Dimension symbol: 3012=3.0x1.2mm
- ③ Internal Code
- ④ Inductance Value:
4R7=4.7uH, 100=10uH, 101=100uH
- ⑤ Tolerance: K=±10%, M=±20%, N=±30%
- ⑥ Packaging Style: C=Carrier Tape, B=bulk
- ⑦ Characteristic Parameter Level

KTNR201610A Electrical Characteristics

Part Number	Inductance (uH) ①	Inductance tolerance	DCR ② (mΩ) Max.	I sat ③ (A) Max.	I sat ③ (A) Typ.	I rms ④ (A) Max.	I rms ④ (A) Typ.
KTNR201610A-R16MCS	0.16	±20%	31	4.30	4.80	3.20	3.50
KTNR201610A-R24MCS	0.24	±20%	40	3.70	4.10	2.90	3.20
KTNR201610A-R33MCS	0.33	±20%	40	2.50	3.10	2.90	3.20
KTNR201610A-R47MCS	0.47	±20%	49	2.30	2.85	2.35	2.60
KTNR201610A-R68MCS	0.68	±20%	65	1.95	2.45	2.05	2.25
KTNR201610A-1R0MCS	1.0	±20%	90	1.65	1.85	1.45	1.60
KTNR201610A-1R5MCS	1.5	±20%	130	1.35	1.65	1.25	1.40
KTNR201610A-2R2MCS	2.2	±20%	170	1.20	1.45	1.10	1.20
KTNR201610A-3R3MCS	3.3	±20%	335	0.90	1.05	0.88	0.98
KTNR201610A-4R7MCS	4.7	±20%	425	0.70	0.85	0.74	0.82
KTNR201610A-6R8MCS	6.8	±20%	816	0.60	0.70	0.52	0.58
KTNR201610A-100MCS	10	±20%	826	0.50	0.55	0.45	0.50

KTNR252010A Electrical Characteristics

Part Number	Inductance (uH) ①	Inductance tolerance	DCR ② (mΩ) Max.	I sat ③ (A) Max.	I sat ③ (A) Typ.	I rms ④ (A) Max.	I rms ④ (A) Typ.
KTNR252010A-R33MCS	0.33	±20%	39	4.80	5.50	3.50	4.05
KTNR252010A-R47MCS	0.47	±20%	45	4.40	5.20	3.20	3.70
KTNR252010A-R68MCS	0.68	±20%	59	3.20	3.60	2.75	3.20
KTNR252010A-1R0MCS	1.0	±20%	76	3.10	3.50	2.50	2.90
KTNR252010A-1R5MCS	1.5	±20%	106	2.60	3.00	2.00	2.30
KTNR252010A-2R2MCS	2.2	±20%	155	1.90	2.20	1.50	1.80
KTNR252010A-3R3MCS	3.3	±20%	235	1.60	1.80	1.20	1.40
KTNR252010A-4R7MCS	4.7	±20%	276	1.30	1.50	1.10	1.30
KTNR252010A-100MCS	10	±20%	500	0.90	1.00	0.80	0.90

KTNR252012A Electrical Characteristics

Part Number	Inductance (uH) ①	Inductance tolerance	DCR ② (mΩ) Max.	I sat ③ (A) Max.	I sat ③ (A) Typ.	I rms ④ (A) Max.	I rms ④ (A) Typ.
KTNR252012A-R24MCS	0.24	±20%	23	6.50	7.80	4.05	4.70
KTNR252012A-R33MCS	0.33	±20%	28	5.30	6.20	3.70	4.30
KTNR252012A-R47MCS	0.47	±20%	35	4.90	5.60	3.45	4.00
KTNR252012A-R68MCS	0.68	±20%	43	3.70	4.30	3.15	3.60
KTNR252012A-1R0MCS	1.0	±20%	54	3.60	4.20	3.00	3.40
KTNR252012A-1R5MCS	1.5	±20%	72	2.90	3.50	2.40	2.80
KTNR252012A-2R2MCS	2.2	±20%	120	2.60	3.00	1.90	2.15
KTNR252012A-3R3MCS	3.3	±20%	163	1.70	2.10	1.80	2.05
KTNR252012A-4R7MCS	4.7	±20%	260	1.60	1.90	1.25	1.45
KTNR252012A-6R8MCS	6.8	±20%	366	1.15	1.35	0.95	1.10
KTNR252012A-100MCS	10	±20%	480	1.10	1.35	0.85	1.00

① Inductance tested at 1.0 MHz/1.0 Vrms using an Agilent/HP 4192A or equivalent.

② DCR measured on a micro-ohmmeter.

③ I sat: The DC current at which the inductance decreases by 30% of its initial value.

④ I rms: The DC current at which $\Delta t=40^{\circ}\text{C}$.

All specifications are subject to change without notice.

KTNR3012A Electrical Characteristics

Part Number	Inductance (uH) ①	Inductance tolerance	DCR ② (mΩ) Max.	I sat ③ (A) Max.	I sat ③ (A) Typ.	I rms ④ (A) Max.	I rms ④ (A) Typ.
KTNR3012A-R33MCS	0.33	±20%	27	7.20	8.90	4.20	4.85
KTNR3012A-R47MCS	0.47	±20%	33	6.80	8.00	3.90	4.50
KTNR3012A-R68MCS	0.68	±20%	42	5.80	6.80	3.40	3.90
KTNR3012A-1R0MCS	1.0	±20%	54	4.20	5.40	2.70	3.10
KTNR3012A-1R5MCS	1.5	±20%	74	3.40	4.10	2.50	2.90
KTNR3012A-2R2MCS	2.2	±20%	108	2.80	3.35	2.05	2.35
KTNR3012A-3R3MCS	3.3	±20%	155	2.20	2.60	1.70	2.00
KTNR3012A-4R7MCS	4.7	±20%	235	2.00	2.50	1.30	1.50
KTNR3012A-6R8MCS	6.8	±20%	340	1.60	1.90	1.10	1.25
KTNR3012A-100MCS	10	±20%	474	1.20	1.45	1.00	1.15

KTNR4012A Electrical Characteristics

Part Number	Inductance (uH) ①	Inductance tolerance	DCR ② (mΩ) Max.	I sat ③ (A) Max.	I sat ③ (A) Typ.	I rms ④ (A) Max.	I rms ④ (A) Typ.
KTNR4012A-R33MCS	0.33	±20%	32	10.3	11.50	4.30	4.90
KTNR4012A-R47MCS	0.47	±20%	41	9.10	9.90	3.80	4.40
KTNR4012A-R68MCS	0.68	±20%	41	5.50	6.35	3.80	4.40
KTNR4012A-1R0MCS	1.0	±20%	59	5.70	6.60	3.20	3.70
KTNR4012A-1R2MCS	1.2	±20%	59	4.00	4.80	3.20	3.70
KTNR4012A-1R5MCS	1.5	±20%	70	3.90	4.60	2.90	3.30
KTNR4012A-2R2MCS	2.2	±20%	79	2.80	3.30	2.70	3.10
KTNR4012A-3R3MCS	3.3	±20%	125	2.80	3.30	2.10	2.50
KTNR4012A-4R7MCS	4.7	±20%	166	2.30	2.60	1.90	2.20
KTNR4012A-6R8MCS	6.8	±20%	226	1.60	2.20	1.60	1.85
KTNR4012A-100MCS	10	±20%	335	1.55	1.85	1.30	1.50
KTNR4012A-220MCS	22	±20%	679	1.05	1.30	0.90	1.05

KTNR4020A Electrical Characteristics

Part Number	Inductance (uH) ①	Inductance tolerance	DCR ② (mΩ) Max.	I sat ③ (A) Max.	I sat ③ (A) Typ.	I rms ④ (A) Max.	I rms ④ (A) Typ.
KTNR4020A-R22MCS	0.22	±20%	13	18.70	22.00	8.20	9.50
KTNR4020A-R47MCS	0.47	±20%	22	13.40	15.50	6.40	7.40
KTNR4020A-R68MCS	0.68	±20%	22	8.70	11.10	6.40	7.40
KTNR4020A-1R0MCS	1.0	±20%	26	8.70	11.10	5.80	6.70
KTNR4020A-1R5MCS	1.5	±20%	36	7.70	9.60	5.20	6.00
KTNR4020A-2R2MCS	2.2	±20%	48	6.10	7.60	4.30	5.00
KTNR4020A-3R3MCS	3.3	±20%	72	4.70	5.90	3.45	4.00
KTNR4020A-4R7MCS	4.7	±20%	108	4.00	4.90	2.85	3.30
KTNR4020A-6R8MCS	6.8	±20%	156	3.00	4.20	2.40	2.80
KTNR4020A-100MCS	10	±20%	216	2.80	3.50	2.00	2.35

① Inductance tested at 1.0 MHz/1.0Vrms using an Agilent/HP 4192A or equivalent.

② DCR measured on a micro-ohmmeter.

③ I sat: The DC current at which the inductance decreases by 30% of it's initial value.

④ I rms: The DC current at which $\Delta t=40^{\circ}\text{C}$.

All specifications are subject to change without notice.

MHF Series Mini Molding Power Inductors

Product Outline

- Alloy powder DC-DC Converter shielded inductors-Mini Molding Types.
- A wide range of product line up is available to meet the various requirements.
- High saturation current, low DCR, high efficiency.
- Very low acoustic noise and very low leakage flux noise.
- Ideally used in MOBILE, flat TV, LCD display, AV devices, car navigation, LED lighting, smart screen, power modules.

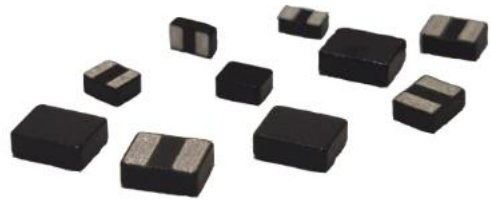

Dimensions(mm)

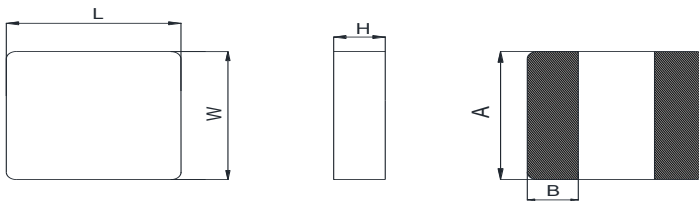

Recommended Patterns

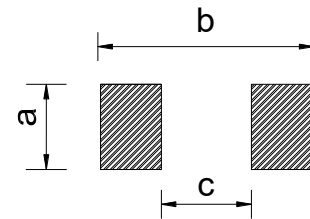

Type	L	W	H	A	B	a	b	c	Packaging (pcs/reel)
MHF141265S	1.4±0.2	1.2±0.2	0.65 Max	1.2	0.45	1.3	1.6	0.4	3000
MHF141207S	1.4±0.2	1.2±0.2	0.7 Max	1.2	0.45	1.3	1.6	0.4	3000
MHF141208S	1.4±0.2	1.2±0.2	0.8 Max	1.2	0.5	1.3	1.6	0.4	3000
MHF160808S	1.6±0.2	0.8±0.2	0.8 Max	0.8	0.55	0.9	1.7	0.4	3000
MHF201265S	2.0±0.2	1.2±0.2	0.65 Max	1.2	0.65	1.4	2.1	0.5	3000
MHF201208S	2.0±0.2	1.2±0.2	0.8 Max	1.2	0.65	1.4	2.1	0.5	3000
MHF201210S	2.0±0.2	1.2±0.2	1.0 Max	1.2	0.65	1.4	2.1	0.5	3000
MHF201212S	2.0±0.2	1.2±0.2	1.2 Max	1.2	0.65	1.4	2.1	0.5	3000
MHF201665S	2.0±0.2	1.6±0.2	0.65 Max	1.6	0.65	1.8	2.1	0.5	3000
MHF201608S	2.0±0.2	1.6±0.2	0.8Max	1.6	0.65	1.8	2.1	0.5	3000
MHF201610S	2.0±0.2	1.6±0.2	1.0 Max	1.6	0.65	1.8	2.1	0.5	3000
MHF201612S	2.0±0.2	1.6±0.2	1.2 Max	1.6	0.65	1.8	2.1	0.5	3000
MHF252008S	2.5±0.2	2.0±0.2	0.8Max	2.0	0.9	2.1	2.6	0.6	3000
MHF252010S	2.5±0.2	2.0±0.2	1.0 Max	2.0	0.9	2.1	2.6	0.6	3000
MHF252012S	2.5±0.2	2.0±0.2	1.2 Max	2.0	0.9	2.1	2.6	0.6	3000
MHF303010S	3.0±0.2	3.0±0.2	1.0 Max	3.0	1.15	3.0	3.2	0.9	3000
MHF303012S	3.0±0.2	3.0±0.2	1.2 Max	3.0	1.15	3.0	3.2	0.9	3000
MHF303015S	3.0±0.2	3.0±0.2	1.5 Max	3.0	1.15	3.0	3.2	0.9	3000
MHF303018S	3.0±0.2	3.0±0.2	1.8 Max	3.0	1.15	3.0	3.2	0.9	3000
MHF303020S	3.0±0.2	3.0±0.2	2.0 Max	3.0	1.15	3.0	3.2	0.9	3000
MHF322510S	3.2±0.2	2.5±0.2	1.0 Max	2.5	1.15	2.6	3.5	0.9	3000
MHF322512S	3.2±0.2	2.5±0.2	1.2 Max	2.5	1.15	2.6	3.5	0.9	3000
MHF322520S	3.2±0.2	2.5±0.2	2.0 Max	2.5	1.15	2.6	3.5	0.9	2000
MHF404010S	4.1±0.2	4.1±0.2	1.0 Max	4.1	1.5	4.1	4.5	1.3	3000
MHF404012S	4.1±0.2	4.1±0.2	1.2 Max	4.1	1.5	4.1	4.5	1.3	3000
MHF404015S	4.1±0.2	4.1±0.2	1.5 Max	4.1	1.5	4.1	4.5	1.3	3000
MHF404030S	4.1±0.2	4.1±0.2	3.0 Max	4.1	1.5	4.1	4.5	1.3	2000

Dimensions without tolerance are typical.

Product Identification

MHF **201610** **S** - **4R7** **M** **C** **S**

① ② ③ ④ ⑤ ⑥ ⑦

- ① Product Series No.
- ② Dimension symbol:2.0x1.6x1.0mm (LxWxH)
- ③ Internal control code.
- ④ Inductance value:100=10×10⁰ uH=10uH 4R7=4.7uH
- ⑤ Tolerance:K=±10%, M=±20%,N=±30%,P=±35%
- ⑥ Packing Style:T=Taping, B=Bulk.
- ⑦ Characteristic parameter level.

MHF141265S Electrical Characteristics

Part Number	Inductance (uH) ①	Inductance Tolerance	DCR ② (mΩ) max.	Isat ③ (A) Max.	Isat③ (A) Typ.	Irms ④ (A) Max.	Irms ④ (A) Typ.
MHF141265S-R24MCS	0.24	±20%	27	5.0	5.5	6.0	6.5
MHF141265S-R33MCS	0.33	±20%	32	4.0	4.4	4.2	4.4
MHF141265S-R47MCS	0.47	±20%	45	3.0	3.4	2.7	3.0

MHF141207S Electrical Characteristics

Part Number	Inductance (uH) ①	Inductance Tolerance	DCR ② (mΩ) max.	Isat ③ (A) Max.	Isat③ (A) Typ.	Irms ④ (A) Max.	Irms ④ (A) Typ.
MHF141207S-R24MCS	0.24	±20%	28	4.3	4.6	3.6	4.0
MHF141207S-R47MCS	0.47	±20%	38	3.5	3.8	3.3	3.8

MHF141208S Electrical Characteristics

Part Number	Inductance (uH) ①	Inductance Tolerance	DCR ② (mΩ) max.	Isat ③ (A) Max.	Isat③ (A) Typ.	Irms ④ (A) Max.	Irms ④ (A) Typ.
MHF141208S-R10MCS	0.1	±20%	14	8.0	8.5	7.5	8.0
MHF141208S-R24MCS	0.24	±20%	27	5.7	6.0	3.7	4.1
MHF141208S-R33MCS	0.33	±20%	28	5.0	5.3	3.5	4.0
MHF141208S-R47MCS	0.47	±20%	35	4.2	4.6	3.3	3.8
MHF141208S-1R0MCS	1.0	±20%	77	2.5	3.0	2.5	3.0
MHF141208S-2R2MCS	2.2	±20%	225	1.7	1.9	1.8	2.0

MHF160808S Electrical Characteristics

Part Number	Inductance (uH) ①	Inductance Tolerance	DCR ② (mΩ) max.	Isat ③ (A) Max.	Isat ③ (A) Typ.	Irms ④ (A) Max.	Irms ④ (A) Typ.
MHF160808S-R18MCS	0.18	±20%	21	5.5	6.0	5.2	5.8
MHF160808S-R22MCS	0.22	±20%	40	5.0	5.5	3.0	3.4
MHF160808S-R24MCS	0.24	±20%	41	4.8	5.3	2.9	3.3
MHF160808S-R33MCS	0.33	±20%	35	4.4	4.7	4.3	4.7
MHF160808S-R47MCS	0.47	±20%	100	3.7	4.1	2.3	2.6
MHF160808S-R56MCS	0.56	±20%	110	3.5	4.0	1.9	2.2
MHF160808S-R68MCS	0.68	±20%	130	3.0	3.3	1.9	2.1
MHF160808S-1R0MCS	1.0	±20%	200	2.6	3.0	1.8	2.1
MHF160808S-1R5MCS	1.5	±20%	285	2.0	2.4	1.4	1.7
MHF160808S-2R2MCS	2.2	±20%	260	1.3	1.5	1.2	1.4
MHF160808S-3R3MCS	3.3	±20%	600	1.2	1.4	0.9	1.0
MHF160808S-4R7MCS	4.7	±20%	700	1.0	1.2	0.8	1.0
MHF160808S-100MCS	10	±20%	1600	0.7	0.8	0.45	0.5

All specifications are subject to change without notice.

MHF Series

Mini Molding Power Inductors

MHF201265S Electrical Characteristics

Part Number	Inductance (uH) ①	Inductance Tolerance	DCR ② (mΩ) max.	Isat ③ (A) Max.	Isat ③ (A) Typ.	Irms ④ (A) Max.	Irms ④ (A) Typ.
MHF201265S-R15MCS	0.15	±20%	14	6.0	6.5	5.5	6.0
MHF201265S-R24MCS	0.24	±20%	20	4.8	5.1	4.5	4.8
MHF201265S-R68MCS	0.68	±20%	60	3.2	3.5	3.0	3.3
MHF201265S-1R0MCS	1.0	±20%	86	2.5	2.8	2.3	2.6
MHF201265S-2R2MCS	2.2	±20%	230	1.5	1.8	1.4	1.7
MHF201265S-4R7MCS	4.7	±20%	530	1.0	1.2	0.9	1.1

MHF201208S Electrical Characteristics

Part Number	Inductance (uH) ①	Inductance Tolerance	DCR ② (mΩ) max.	Isat ③ (A) Max.	Isat ③ (A) Typ.	Irms ④ (A) Max.	Irms ④ (A) Typ.
MHF201208S-R11MCS	0.11	±20%	12	9.0	9.5	6.5	7.0
MHF201208S-R15MCS	0.15	±20%	13	7.0	7.5	6.3	6.8
MHF201208S-R24MCS	0.24	±20%	23	6.0	6.5	5.9	6.5
MHF201208S-R33MCS	0.33	±20%	45	4.8	5.2	4.0	4.3
MHF201208S-R47MCS	0.47	±20%	50	4.6	5.0	3.4	3.7
MHF201208S-R68MCS	0.68	±20%	60	3.7	4.2	3.3	3.6
MHF201208S-1R0MCS	1.0	±20%	70	3.5	4.0	2.9	3.3
MHF201208S-1R5MCS	1.5	±20%	135	2.5	3.0	1.9	2.3
MHF201208S-2R2MCS	2.2	±20%	185	2.3	2.6	1.8	2.2
MHF201208S-3R3MCS	3.3	±20%	300	1.6	1.9	1.5	1.8
MHF201208S-4R7MCS	4.7	±20%	325	1.4	1.6	1.5	1.7
MHF201208S-6R8MCS	6.8	±20%	530	1.1	1.3	1.0	1.1

MHF201210S Electrical Characteristics

Part Number	Inductance (uH) ①	Inductance Tolerance	DCR ② (mΩ) max.	Isat ③ (A) Max.	Isat ③ (A) Typ.	Irms ④ (A) Max.	Irms ④ (A) Typ.
MHF201210S-R10MCS	0.1	±20%	13	8.0	8.5	7.0	7.5
MHF201210S-R11MCS	0.11	±20%	8.5	12	14.1	9.5	10
MHF201210S-R22MCS	0.22	±20%	22	6.8	7.3	6.5	7.1
MHF201210S-R24MCS	0.24	±20%	23	6.7	7.2	6.4	7.0
MHF201210S-R33MCS	0.33	±20%	32	6.0	6.5	5.0	5.5
MHF201210S-R47MCS	0.47	±20%	36	5.0	5.5	4.3	4.7
MHF201210S-R56MCS	0.56	±20%	31	4.8	5.2	4.7	5.3
MHF201210S-R68MCS	0.68	±20%	43	4.5	5.0	4.0	4.3
MHF201210S-1R0MCS	1.0	±20%	63	3.5	4.0	3.5	3.9
MHF201210S-1R5MCS	1.5	±20%	85	2.7	3.2	2.6	3.1
MHF201210S-2R2MCS	2.2	±20%	150	2.4	2.7	1.7	2.0
MHF201210S-3R3MCS	3.3	±20%	260	1.8	2.2	1.5	1.8
MHF201210S-4R7MCS	4.7	±20%	300	1.6	1.8	1.4	1.6
MHF201210S-6R8MCS	6.8	±20%	520	1.2	1.45	1.3	1.5
MHF201210S-100MCS	10	±20%	660	1.0	1.2	1.0	1.1

MHF Series

Mini Molding Power Inductors

MHF201212S Electrical Characteristics

Part Number	Inductance (uH) ①	Inductance Tolerance	DCR ② (mΩ) max.	Isat ③ (A) Max.	Isat ③ (A) Typ.	Irms ④ (A) Max.	Irms ④ (A) Typ.
MHF201212S-R11MCS	0.11	±20%	6.2	11	12	11	12
MHF201212S-R24MCS	0.24	±20%	16	8.5	9.0	7.0	7.5
MHF201212S-R33MCS	0.33	±20%	20.5	6.0	6.5	5.8	6.3
MHF201212S-R47MCS	0.47	±20%	23.5	5.0	5.5	5.5	6.0
MHF201212S-1R0MCS	1.0	±20%	48	3.6	4.0	3.5	3.9
MHF201212S-3R3MCS	3.3	±20%	210	1.8	2.0	1.6	1.8

MHF201665S Electrical Characteristics

Part Number	Inductance (uH) ①	Inductance Tolerance	DCR ② (mΩ) max.	Isat ③ (A) Max.	Isat ③ (A) Typ.	Irms ④ (A) Max.	Irms ④ (A) Typ.
MHF201665S-R47MCS	0.47	±20%	40	4.0	4.4	4.5	5.0
MHF201665S-R68MCS	0.68	±20%	50	3.1	3.4	3.5	4.0
MHF201665S-1R0MCS	1.0	±20%	70	2.7	3.0	3.0	3.5
MHF201665S-2R2MCS	2.2	±20%	170	2.0	2.2	2.6	2.8

MHF201608S Electrical Characteristics

Part Number	Inductance (uH) ①	Inductance Tolerance	DCR ② (mΩ) max.	Isat ③ (A) Max.	Isat ③ (A) Typ.	Irms ④ (A) Max.	Irms ④ (A) Typ.
MHF201608S-R22MCS	0.22	±20%	19	5.6	6.1	5.9	6.6
MHF201608S-R24MCS	0.24	±20%	20	5.5	6.0	5.8	6.5
MHF201608S-R33MCS	0.33	±20%	24	5.3	5.8	4.8	5.5
MHF201608S-R47MCS	0.47	±20%	27	5.0	5.5	5.2	5.5
MHF201608S-R68MCS	0.68	±20%	44	4.2	4.6	3.5	3.8
MHF201608S-1R0MCS	1.0	±20%	60	3.1	3.3	3.3	3.6
MHF201608S-1R5MCS	1.5	±20%	85	2.8	3.0	2.8	3.1
MHF201608S-2R2MCS	2.2	±20%	140	2.3	2.5	2.0	2.2
MHF201608S-3R3MCS	3.3	±20%	220	1.8	2.1	1.5	1.8
MHF201608S-4R7MCS	4.7	±20%	290	1.5	1.7	1.4	1.6
MHF201608S-6R8MCS	6.8	±20%	405	1.3	1.4	1.2	1.4
MHF201608S-100MCS	10	±20%	800	0.9	1.0	0.9	1.0

① Inductance tested at 1MHz/1.0 Vrms using an Agilent/HP 4284A or equivalent.

② DCR measured on a micro-ohmmeter.

③ Isat: The DC current at which the inductance decreases by 30% of it's initial value.

④ Irms: The DC current at which $\Delta t=40^{\circ}\text{C}$.

MHF Series

Mini Molding Power Inductors

MHF201610S Electrical Characteristics

Part Number	Inductance (uH) ①	Inductance Tolerance	DCR ② (mΩ) max.	Isat ③ (A) Max.	Isat ③ (A) Typ.	Irms ④ (A) Max.	Irms ④ (A) Typ.
MHF201610S-R10MCS	0.1	±20%	12	8.4	9.0	8.0	8.5
MHF201610S-R11MCS	0.11	±20%	13	8.2	8.9	7.5	8.0
MHF201610S-R15MCS	0.15	±20%	14	8.0	8.7	7.0	7.6
MHF201610S-R22MCS	0.22	±20%	18	7.5	8.2	6.3	6.9
MHF201610S-R24MCS	0.24	±20%	19	7.4	8.0	6.2	6.8
MHF201610S-R33MCS	0.33	±20%	22	6.5	7.0	5.3	5.7
MHF201610S-R47MCS	0.47	±20%	25	5.5	6.3	5.0	5.5
MHF201610S-R56MCS	0.56	±20%	23	5.0	5.5	7.0	7.5
MHF201610S-R68MCS	0.68	±20%	32	4.7	5.2	4.3	4.6
MHF201610S-1R0MCS	1.0	±20%	43	4.2	4.6	4.1	4.5
MHF201610S-1R5MCS	1.5	±20%	100	2.9	3.2	2.3	2.6
MHF201610S-2R2MCS	2.2	±20%	130	2.8	3.0	2.1	2.5
MHF201610S-3R3MCS	3.3	±20%	170	2.0	2.3	1.5	1.7
MHF201610S-4R7MCS	4.7	±20%	220	1.8	2.0	1.4	1.6
MHF201610S-6R8MCS	6.8	±20%	350	1.5	1.7	1.5	1.7
MHF201610S-100MCS	10	±20%	580	1.1	1.4	0.7	1.0

MHF201612S Electrical Characteristics

Part Number	Inductance (uH) ①	Inductance Tolerance	DCR ② (mΩ) max.	Isat ③ (A) Max.	Isat ③ (A) Typ.	Irms ④ (A) Max.	Irms ④ (A) Typ.
MHF201612S-R10MCS	0.1	±20%	6.0	11.5	13	10	12
MHF201612S-R11MCS	0.11	±20%	5.6	11	12.5	14.5	15.5
MHF201612S-R15MCS	0.15	±20%	10	10.5	12	9.0	10
MHF201612S-R22MCS	0.22	±20%	10.5	9.2	9.7	8.8	9.3
MHF201612S-R24MCS	0.24	±20%	11	8.7	9.2	8.6	9.1
MHF201612S-R33MCS	0.33	±20%	15	7.3	7.8	7.2	7.7
MHF201612S-R47MCS	0.47	±20%	17	6.0	6.7	6.0	6.7
MHF201612S-R68MCS	0.68	±20%	23	5.3	6.0	5.3	6.0
MHF201612S-1R0MCS	1.0	±20%	36	4.5	5.0	4.5	5.0
MHF201612S-1R5MCS	1.5	±20%	50	3.5	4.0	3.5	4.0
MHF201612S-2R2MCS	2.2	±20%	90	2.7	3.1	2.9	3.3
MHF201612S-3R3MCS	3.3	±20%	165	2.3	2.7	2.0	2.4
MHF201612S-6R8MCS	6.8	±20%	300	1.7	1.9	1.7	1.8

MHF252008S Electrical Characteristics

Part Number	Inductance (uH) ①	Inductance Tolerance	DCR ② (mΩ) max.	Isat ③ (A) Max.	Isat ③ (A) Typ.	Irms ④ (A) Max.	Irms ④ (A) Typ.
MHF252008S-R47MCS	0.47	±20%	27	5.3	6.0	6.0	6.5
MHF252008S-R68MCS	0.68	±20%	32	4.5	5.0	4.4	4.9
MHF252008S-1R0MCS	1.0	±20%	40	4.0	4.5	4.0	4.3
MHF252008S-1R5MCS	1.5	±20%	75	3.0	3.5	3.0	3.4
MHF252008S-2R2MCS	2.2	±20%	77	2.6	3.0	2.6	3.0
MHF252008S-3R3MCS	3.3	±20%	180	2.1	2.5	2.1	2.5
MHF252008S-4R7MCS	4.7	±20%	215	1.5	1.9	1.5	2.0
MHF252008S-100MCS	10	±20%	600	0.9	1.1	1.2	1.4

All specifications are subject to change without notice.

MHF Series

Mini Molding Power Inductors

MHF252010S Electrical Characteristics

Part Number	Inductance (uH) ①	Inductance Tolerance	DCR ② (mΩ) max.	Isat ③ (A) Max.	Isat ③ (A) Typ.	Irms ④ (A) Max.	Irms ④ (A) Typ.
MHF252010S-R10MCS	0.10	±20%	8.5	12.5	13.5	11	12
MHF252010S-R15MCS	0.15	±20%	9.0	9.5	10.5	8.5	9.5
MHF252010S-R22MCS	0.22	±20%	17	7.9	8.6	6.5	6.8
MHF252010S-R24MCS	0.24	±20%	17	7.9	8.6	6.4	6.7
MHF252010S-R33MCS	0.33	±20%	19	7.3	7.7	6.25	6.45
MHF252010S-R47MCS	0.47	±20%	22	6.45	7.0	5.65	6.15
MHF252010S-R68MCS	0.68	±20%	27	5.6	5.88	5.05	5.75
MHF252010S-R82MCS	0.82	±20%	29	4.8	5.3	4.1	4.5
MHF252010S-1R0MCS	1.0	±20%	30	4.85	5.25	4.12	4.45
MHF252010S-1R5MCS	1.5	±20%	55	3.95	4.35	3.05	3.45
MHF252010S-2R2MCS	2.2	±20%	70	3.1	3.35	2.15	2.5
MHF252010S-3R3MCS	3.3	±20%	98	2.5	2.8	2.1	2.5
MHF252010S-4R7MCS	4.7	±20%	175	2.0	2.65	1.6	2.0
MHF252010S-6R8MCS	6.8	±20%	315	1.95	2.45	1.45	1.6
MHF252010S-100MCS	10	±20%	550	1.45	1.58	0.97	1.1

MHF252012S Electrical Characteristics

Part Number	Inductance (uH) ①	Inductance Tolerance	DCR ② (mΩ) max.	Isat ③ (A) Max.	Isat ③ (A) Typ.	Irms ④ (A) Max.	Irms ④ (A) Typ.
MHF252012S-R10MCS	0.10	±20%	7.5	12.5	13.5	10.5	12
MHF252012S-R15MCS	0.15	±20%	10	12	13	10	11.5
MHF252012S-R22MCS	0.22	±20%	13	9.0	9.6	7.6	8.2
MHF252012S-R24MCS	0.24	±20%	15	8.8	9.3	7.55	8.1
MHF252012S-R33MCS	0.33	±20%	17	7.8	8.35	6.45	6.8
MHF252012S-R47MCS	0.47	±20%	19	7.1	7.55	6.1	6.55
MHF252012S-R68MCS	0.68	±20%	23	6.1	6.6	5.6	6.3
MHF252012S-1R0MCS	1.0	±20%	42	5.15	5.7	3.8	4.3
MHF252012S-1R5MCS	1.5	±20%	50	4.15	4.5	3.25	3.7
MHF252012S-2R2MCS	2.2	±20%	65	3.4	3.8	2.8	3.1
MHF252012S-3R3MCS	3.3	±20%	97	2.7	3.05	2.5	2.8
MHF252012S-4R7MCS	4.7	±20%	170	2.15	2.4	1.9	2.2
MHF252012S-6R8MCS	6.8	±20%	270	1.75	2.05	1.6	1.8
MHF252012S-100MCS	10	±20%	400	1.46	1.65	1.05	1.25
MHF252012S-150MCS	15	±20%	565	1.3	1.4	1.3	1.4
MHF252012S-220MCS	22	±20%	800	1.0	1.1	1.1	1.2

MHF303010S Electrical Characteristics

Part Number	Inductance (uH) ①	Inductance Tolerance	DCR ② (mΩ) max.	Isat ③ (A) Max.	Isat ③ (A) Typ.	Irms ④ (A) Max.	Irms ④ (A) Typ.
MHF303010S-1R0MCS	1.0	±20%	35	4.8	5.3	6.5	7.0
MHF303010S-2R2MCS	2.2	±20%	66	3.5	4.0	4.5	5.0
MHF303010S-3R3MCS	3.3	±20%	102	2.8	3.1	3.0	3.4
MHF303010S-4R7MCS	4.7	±20%	140	2.3	2.7	2.8	3.2
MHF303010S-6R8MCS	6.8	±20%	270	1.5	1.8	1.8	2.1
MHF303010S-100MCS	10	±20%	360	1.3	1.6	1.7	2.0

All specifications are subject to change without notice.

MHF303012S Electrical Characteristics

Part Number	Inductance (uH) ①	Inductance Tolerance	DCR ② (mΩ) max.	Isat ③ (A) Max.	Isat ③ (A) Typ.	Irms ④ (A) Max.	Irms ④ (A) Typ.
MHF303012S-R10MCS	0.1	±20%	6.0	18	20	17	18
MHF303012S-R47MCS	0.47	±20%	11	8.0	8.5	10	11
MHF303012S-R68MCS	0.68	±20%	16	6.5	7.0	7.0	7.5
MHF303012S-1R0MCS	1.0	±20%	27	5.5	6.0	5.0	5.5
MHF303012S-1R5MCS	1.5	±20%	34	5.0	5.5	5.5	6.0
MHF303012S-2R2MCS	2.2	±20%	50	4.5	5.0	4.3	4.8
MHF303012S-4R7MCS	4.7	±20%	120	2.5	3.0	2.5	3.0
MHF303012S-100MCS	10	±20%	220	2.0	2.3	1.9	2.3
MHF303012S-150MCS	15	±20%	380	1.6	1.9	1.3	1.6

MHF303015S Electrical Characteristics

Part Number	Inductance (uH) ①	Inductance Tolerance	DCR ② (mΩ) max.	Isat ③ (A) Max.	Isat ③ (A) Typ.	Irms ④ (A) Max.	Irms ④ (A) Typ.
MHF303015S-R15MCS	0.15	±20%	6.0	15	16	11	12
MHF303015S-R20MCS	0.2	±20%	5.9	15	16	12	13
MHF303015S-R33MCS	0.33	±20%	8.5	11	12	13	14
MHF303015S-R47MCS	0.47	±20%	11	9.0	10	8.0	9.0
MHF303015S-1R0MCS	1.0	±20%	22	6.5	7.0	5.5	6.0
MHF303015S-1R5MCS	1.5	±20%	26	5.5	6.0	7.5	8.0
MHF303015S-2R2MCS	2.2	±20%	50	4.5	5.0	4.0	4.5
MHF303015S-4R7MCS	4.7	±20%	104	3.5	4.0	3.0	3.5
MHF303015S-6R8MCS	6.8	±20%	180	3.0	3.5	2.0	2.5
MHF303015S-100MCS	10	±20%	215	2.5	2.8	1.5	2.0
MHF303015S-220MCS	22	±20%	700	1.2	1.6	1.0	1.2

MHF303018S Electrical Characteristics

Part Number	Inductance (uH) ①	Inductance Tolerance	DCR ② (mΩ) max.	Isat ③ (A) Max.	Isat ③ (A) Typ.	Irms ④ (A) Max.	Irms ④ (A) Typ.
MHF303018S-R22MCS	0.22	±20%	7.0	16	17	9.0	10
MHF303018S-R47MCS	0.47	±20%	10	11	12	8.0	9.0
MHF303018S-R68MCS	0.68	±20%	14.5	10	11	9.0	10
MHF303018S-1R0MCS	1.0	±20%	21	6.8	7.6	5.8	6.3
MHF303018S-1R5MCS	1.5	±20%	26	7.0	8.0	6.4	6.8
MHF303018S-4R7MCS	4.7	±20%	87	4.2	4.7	3.0	3.4

- ① Inductance tested at 1MHz/1.0 Vrms using an Agilent/HP 4284A or equivalent.
- ② DCR measured on a micro-ohmmeter.
- ③ Isat: The DC current at which the inductance decreases by 30% of it's initial value.
- ④ Irms: The DC current at which $\Delta t=40^{\circ}\text{C}$.

MHF303020S Electrical Characteristics

Part Number	Inductance (uH) ①	Inductance Tolerance	DCR ② (mΩ) max.	Isat ③ (A) Max.	Isat ③ (A) Typ.	Irms ④ (A) Max.	Irms ④ (A) Typ.
MHF303020S-R10MCS	0.1	±20%	4.5	23	25	16	17
MHF303020S-R15MCS	0.15	±20%	5.0	17	18	12	13
MHF303020S-R22MCS	0.22	±20%	6.5	16	17.5	10	11
MHF303020S-R33MCS	0.33	±20%	9.0	15	17	9.0	10
MHF303020S-R36MCS	0.36	±20%	9.0	14.5	16.5	9.0	10
MHF303020S-R47MCS	0.47	±20%	11	13.5	15	8.0	9.0
MHF303020S-R50MCS	0.5	±20%	12	13	15	8.0	9.0
MHF303020S-R68MCS	0.68	±20%	16	11	13	7.8	8.5
MHF303020S-1R0MCS	1.0	±20%	20	7.3	8.0	6.0	6.5
MHF303020S-1R5MCS	1.5	±20%	25	6.5	7.0	5.8	6.3
MHF303020S-2R2MCS	2.2	±20%	45	5.5	6.0	4.3	4.7
MHF303020S-3R3MCS	3.3	±20%	63	5.4	5.9	4.0	4.5
MHF303020S-4R7MCS	4.7	±20%	73	4.0	4.8	3.8	4.2
MHF303020S-6R8MCS	6.8	±20%	135	3.8	4.5	3.0	3.2
MHF303020S-100MCS	10	±20%	160	3.3	3.8	2.2	2.5
MHF303020S-150MCS	15	±20%	260	2.2	2.6	1.5	1.8

MHF322510S Electrical Characteristics

Part Number	Inductance (uH) ①	Inductance Tolerance	DCR ② (mΩ) max.	Isat ③ (A) Max.	Isat ③ (A) Typ.	Irms ④ (A) Max.	Irms ④ (A) Typ.
MHF322510S-R22MCS	0.22	±20%	11	8.0	8.5	8.0	8.5
MHF322510S-R33MCS	0.33	±20%	15	7.8	8.3	7.8	8.3
MHF322510S-R47MCS	0.47	±20%	22	7.6	8.3	5.9	6.4
MHF322510S-R68MCS	0.68	±20%	28	7.0	7.5	5.7	6.2
MHF322510S-1R0MCS	1.0	±20%	30	5.3	6.0	4.9	5.4
MHF322510S-1R5MCS	1.5	±20%	42	4.4	5.0	3.6	4.0
MHF322510S-2R2MCS	2.2	±20%	66	3.5	4.0	3.4	3.7
MHF322510S-3R3MCS	3.3	±20%	120	3.3	3.7	2.3	2.7
MHF322510S-4R7MCS	4.7	±20%	140	2.5	2.8	1.9	2.3
MHF322510S-6R8MCS	6.8	±20%	320	2.0	2.4	1.6	1.9
MHF322510S-100MCS	10	±20%	365	1.8	2.2	1.8	2.2

MHF322512S Electrical Characteristics

Part Number	Inductance (uH) ①	Inductance Tolerance	DCR ② (mΩ) max.	Isat ③ (A) Max.	Isat ③ (A) Typ.	Irms ④ (A) Max.	Irms ④ (A) Typ.
MHF322512S-R10MCS	0.10	±20%	7.0	16.5	18	11	12
MHF322512S-R22MCS	0.22	±20%	10	11	11.5	8.7	9.2
MHF322512S-R24MCS	0.24	±20%	12	10.5	11	8.5	9.0
MHF322512S-R33MCS	0.33	±20%	14	9.2	10	8.1	8.45
MHF322512S-R47MCS	0.47	±20%	19	8.2	8.6	7.2	7.5
MHF322512S-R68MCS	0.68	±20%	23	7.7	8.15	6.8	7.3
MHF322512S-1R0MCS	1.0	±20%	30	5.8	6.6	4.8	5.3
MHF322512S-1R5MCS	1.5	±20%	44	4.7	5.1	4.3	4.7
MHF322512S-2R2MCS	2.2	±20%	70	4.2	4.6	3.0	3.6
MHF322512S-3R3MCS	3.3	±20%	95	3.25	3.7	2.5	2.95
MHF322512S-4R7MCS	4.7	±20%	135	2.6	2.9	2.0	2.3
MHF322512S-6R8MCS	6.8	±20%	210	2.45	2.85	1.95	2.1
MHF322512S-100MCS	10	±20%	240	1.9	2.3	1.85	2.2

All specifications are subject to change without notice.

MHF322520S Electrical Characteristics

Part Number	Inductance (uH) ①	Inductance Tolerance	DCR ② (mΩ) max.	Isat ③ (A) Max.	Isat ③ (A) Typ.	Irms ④ (A) Max.	Irms ④ (A) Typ.
MHF322520S-70NMCS	0.07	±20%	3.2	24	25	20	22
MHF322520S-R27MCS	0.27	±20%	6.5	15	16	15	16
MHF322520S-R33MCS	0.33	±20%	9.0	14	15.5	9.0	9.5
MHF322520S-R47MCS	0.47	±20%	10.5	13	15	8.5	9.5
MHF322520S-R68MCS	0.68	±20%	14.5	11	13	8.0	9.0
MHF322520S-1R0MCS	1.0	±20%	17.5	8.3	9.0	7.5	8.2
MHF322520S-1R5MCS	1.5	±20%	25	6.0	6.8	6.0	6.5
MHF322520S-2R2MCS	2.2	±20%	43	5.5	6.5	4.8	5.4
MHF322520S-3R3MCS	3.3	±20%	60	3.5	4.5	4.0	4.5
MHF322520S-4R7MCS	4.7	±20%	94	3.0	4.0	3.0	3.5
MHF322520S-6R8MCS	6.8	±20%	125	2.9	3.8	2.3	2.8
MHF322520S-150MCS	15	±20%	260	2.0	2.2	1.8	2.0
MHF322520S-220MCS	22	±20%	364	1.7	2.0	1.5	1.8

MHF404010S Electrical Characteristics

Part Number	Inductance (uH) ①	Inductance Tolerance	DCR ② (mΩ) max.	Isat ③ (A) Max.	Isat ③ (A) Typ.	Irms ④ (A) Max.	Irms ④ (A) Typ.
MHF404010S-1R0MCS	1.0	±20%	26	4.8	5.3	6.5	7.0
MHF404010S-4R7MCS	4.7	±20%	140	3.5	3.8	3.0	3.4
MHF404010S-100MCS	10	±20%	280	2.0	2.2	2.0	2.5

MHF404012S Electrical Characteristics

Part Number	Inductance (uH) ①	Inductance Tolerance	DCR ② (mΩ) max.	Isat ③ (A) Max.	Isat ③ (A) Typ.	Irms ④ (A) Max.	Irms ④ (A) Typ.
MHF404012S-R47MCS	0.47	±20%	14	11.5	12	8.5	9.0
MHF404012S-R60MCS	0.6	±20%	14.5	8.5	9.0	8.0	8.5
MHF404012S-R68MCS	0.68	±20%	18	9.0	10	7.5	8.5
MHF404012S-1R0MCS	1.0	±20%	25	10	11	5.5	6.3
MHF404012S-1R5MCS	1.5	±20%	34.5	7.0	8.0	5.0	6.0
MHF404012S-2R2MCS	2.2	±20%	55	6.0	6.5	4.5	5.0
MHF404012S-3R3MCS	3.3	±20%	80	5.0	5.5	4.0	4.5
MHF404012S-4R7MCS	4.7	±20%	110	4.5	5.0	3.0	3.5
MHF404012S-5R6MCS	5.6	±20%	140	4.0	4.5	2.5	3.0
MHF404012S-6R8MCS	6.8	±20%	160	3.5	3.8	2.3	2.8
MHF404012S-100MCS	10	±20%	235	2.5	2.8	2.0	2.5

MHF404015S Electrical Characteristics

Part Number	Inductance (uH) ①	Inductance Tolerance	DCR ② (mΩ) max.	Isat ③ (A) Max.	Isat ③ (A) Typ.	Irms ④ (A) Max.	Irms ④ (A) Typ.
MHF404015S-4R7MCS	4.7	±20%	63	5.0	5.5	4.5	5.0
MHF404015S-5R6MCS	5.6	±20%	80	4.3	4.8	4.0	4.5

① Inductance tested at 1MHz/1.0 Vrms using an Agilent/HP 4284A or equivalent.

② DCR measured on a micro-ohmmeter.

③ Isat: The DC current at which the inductance decreases by 30% of it's initial value.

④ Irms: The DC current at which $\Delta t=40^{\circ}\text{C}$.

MHF404030S Electrical Characteristics

Part Number	Inductance (uH) ①	Inductance Tolerance	DCR ② (mΩ) max.	Isat ③ (A) Max.	Isat ③ (A) Typ.	Irms ④ (A) Max.	Irms ④ (A) Typ.
MHF404030S-R33MCS	0.33	±20%	6.0	23	25	15	16
MHF404030S-R47MCS	0.47	±20%	7.0	21	23	14	15
MHF404030S-R56MCS	0.56	±20%	7.5	20	22	14	15
MHF404030S-R68MCS	0.68	±20%	10	15	17	8.0	9.5
MHF404030S-6R8MCS	6.8	±20%	62	5.1	6.3	3.8	4.2
MHF404030S-8R2MCS	8.2	±20%	102	4.8	5.2	3.5	3.9
MHF404030S-100MCS	10	±20%	110	4.5	4.9	3.3	3.7
MHF404030S-220MCS	22	±20%	220	3.0	3.4	2.2	2.5

- ① Inductance tested at 1MHz/1.0 Vrms using an Agilent/HP 4284A or equivalent.
- ② DCR measured on a micro-ohmmeter.
- ③ sat: The DC current at which the inductance decreases by 30% of it's initial value.
- ④ Irms: The DC current at which $\Delta t=40^{\circ}\text{C}$.

MTA Series SMD Molding Power Inductors

Product Outline

- Alloy powder DC-DC Converter shielded inductors.
- A wide range of product line up is available to meet the various requirements.
- High saturation current, low DCR, high efficiency.
- Very low acoustic noise and very low leakage flux noise.
- Ideally used in flat TV, LCD display, AV devices, car navigation, LED lighting, smart screen, power modules.

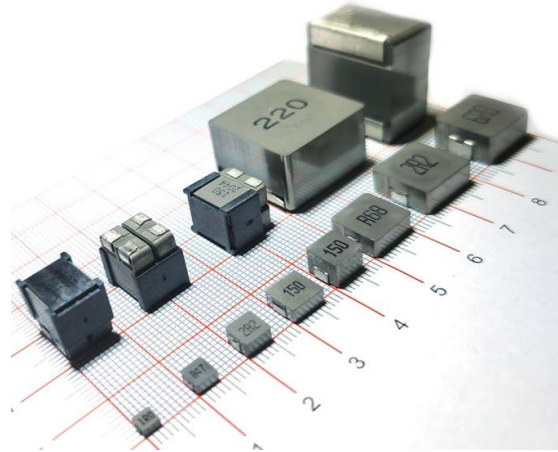

Dimensions(mm)

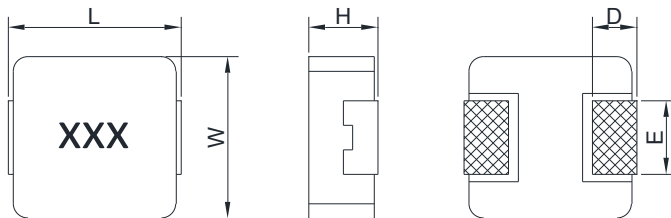

Recommended Patterns

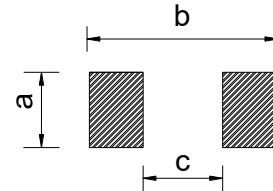

Type	L	W	H	D	E	a	b	c	Packaging (pcs/reel)
MTA3015S	3.4±0.2	3.0±0.2	1.3±0.2	0.7	1.3	2.0	4.2	1.2	3000
MTA4012S	4.4±0.35	4.2±0.25	1.0±0.2	1.0	2.0	2.5	5.2	2.2	3000
MTA4020S	4.4±0.35	4.2±0.25	1.8±0.2	1.0	2.0	2.5	5.2	2.2	3000
MTA5018S	5.4±0.35	5.2±0.25	1.6±0.2	1.2	2.2	2.5	6.0	2.2	2000
MTA5030S	5.4±0.35	5.2±0.25	2.8±0.2	1.2	2.2	2.5	6.0	2.2	2000
MTA6018S	7.1±0.4	6.6±0.2	1.6±0.2	1.6	3.0	3.5	8.4	3.7	2000
MTA6020S	7.1±0.4	6.6±0.2	1.8±0.2	1.6	3.0	3.5	8.4	3.7	2000
MTA6024S	7.1±0.4	6.6±0.2	2.2±0.2	1.6	3.0	3.5	8.4	3.7	1500
MTA6030S	7.1±0.4	6.6±0.2	2.8±0.2	1.6	3.0	3.5	8.4	3.7	1000
MTA6040S	7.1±0.4	6.6±0.2	3.8±0.2	1.6	3.0	3.5	8.4	3.7	1000
MTA6050S	7.1±0.4	6.6±0.2	4.8±0.2	1.6	3.0	3.5	8.4	3.7	1000
MTA8040S	8.5±0.5	8.0±0.2	3.8±0.2	1.8	3.0	3.5	9.5	4.0	1000
MTA8050S	8.5±0.5	8.0±0.2	4.8±0.2	1.8	3.0	3.5	9.5	4.0	1000
MTA1030S	11.5 Max	10.0±0.3	2.8±0.2	2.0	3.0	3.5	13.6	5.4	1000
MTA1040S	11.5 Max	10.0±0.3	3.8±0.2	2.0	3.0	3.5	13.6	5.4	1000
MTA1050S	11.5 Max	10.0±0.3	4.8±0.2	2.0	3.0	3.5	13.6	5.4	800
MTA1240S	13.45±0.35	12.8±0.5	4.0 Max.	2.2	3.8	4.5	14.5	8.0	800
MTA1250S	13.45±0.35	12.6±0.5	4.8±0.2	2.2	3.8	4.5	14.5	8.0	500
MTA1260S	13.45±0.35	12.6±0.5	5.8±0.2	2.2	3.8	4.5	14.5	8.0	500
MTA1265S	13.45±0.35	12.6±0.5	6.5 Max.	2.2	3.8	4.5	14.5	8.0	500
MTA1707S	17.15±0.35	17.2 Max	7.0 Max	2.5	12.0	12.8	18.2	11.2	200

Dimensions without tolerance are typical.

Product Identification

MTA **1040** **S** - **6R8** **M** **C** **S**

① ② ③ ④ ⑤ ⑥ ⑦

- ① Product Series No.
- ② Dimension symbol:1040=10.0 x 3.8 mm (W x H)
- ③ Internal control code.
- ④ Inductance value:100=10×10⁰ uH=10uH,6R8=6.8uH
- ⑤ Tolerance:M=±20%,N=±30%,P=±35%
- ⑥ Packing Style:T=Taping, B=Bulk
- ⑦ Characteristic parameter level.

MTA3015S Electrical Characteristics

Part Number	Inductance (uH) ①	Inductance Tolerance	DCR ② (mΩ) max.	Isat ③ (A) Max.	Isat③ (A) Typ.	Irms ④ (A) Max.	Irms ④ (A) Typ.
MTA3015S-R22MCS	0.22	±20%	13	11.2	14.0	8.8	11.0
MTA3015S-R33MCS	0.33	±20%	18	9.2	11.5	6.8	8.5
MTA3015S-R47MCS	0.47	±20%	22	7.2	9.0	5.6	7.0
MTA3015S-1R0MCS	1.0	±20%	42	4.96	6.2	3.6	4.5
MTA3015S-1R5MCS	1.5	±20%	60	4.64	5.8	3.04	3.8
MTA3015S-2R2MCS	2.2	±20%	85	4.0	5.0	2.56	3.2
MTA3015S-3R3MCS	3.3	±20%	110	2.8	3.5	1.76	2.2
MTA3015S-100MCS	10.0	±20%	360	1.6	2.0	0.96	1.2

MTA4012S Electrical Characteristics

Part Number	Inductance (uH) ①	Inductance Tolerance	DCR ② (mΩ) max.	Isat ③ (A) Max.	Isat ③ (A) Typ.	Irms ④ (A) Max.	Irms ④ (A) Typ.
MTA4012S-R15MCS	0.15	±20%	9.0	12.0	15.0	6.8	7.5
MTA4012S-R22MCS	0.22	±20%	11	8.8	11.0	6.5	7.0
MTA4012S-R33MCS	0.33	±20%	19	6.7	8.4	5.7	6.5
MTA4012S-R47MCS	0.47	±20%	21	5.4	6.8	5.2	6.0
MTA4012S-R68MCS	0.68	±20%	36	4.8	6.0	4.2	4.7
MTA4012S-1R0MCS	1.0	±20%	47	4.4	5.5	3.8	4.5
MTA4012S-1R5MCS	1.5	±20%	75	3.2	4.0	2.7	3.25
MTA4012S-2R2MCS	2.2	±20%	83.5	2.4	3.0	2.2	2.75
MTA4012S-4R7MCS	4.7	±20%	195	1.8	2.2	1.45	1.8

- ① Inductance tested at 100kHz, 0.5 Vrms using an Agilent/HP 4192A or equivalent.
- ② DCR measured on a micro-ohmmeter.
- ③ Isat: The DC current at which the inductance decreases by 30% of it's initial value.
- ④ Irms: The DC current at which Δt=40°C.

MTA4020S Electrical Characteristics

Part Number	Inductance (uH) ①	Inductance Tolerance	DCR ② (mΩ) max.	Isat ③ (A) Max.	Isat ③ (A) Typ.	Irms ④ (A) Max.	Irms ④ (A) Typ.
MTA4020S-R10MCS	0.10	±20%	4.0	17.6	22.0	11.2	13.0
MTA4020S-R22MCS	0.22	±20%	6.6	10.0	12.5	9.0	10.5
MTA4020S-R33MCS	0.33	±20%	11	9.6	12.0	8.6	10.0
MTA4020S-R47MCS	0.47	±20%	14	7.6	9.5	6.65	7.5
MTA4020S-R56MCS	0.56	±20%	16	7.2	9.0	6.1	7.0
MTA4020S-R68MCS	0.68	±20%	18	6.4	8.0	6.15	7.0
MTA4020S-1R0MCS	1.0	±20%	27	5.6	7.0	5.4	6.0
MTA4020S-1R2MCS	1.2	±20%	27	5.2	6.5	5.4	6.0
MTA4020S-1R5MCS	1.5	±20%	46	4.4	5.5	4.3	5.0
MTA4020S-2R2MCS	2.2	±20%	58	4.0	5.0	3.8	4.5
MTA4020S-3R3MCS	3.3	±20%	87	2.8	3.5	2.8	3.3
MTA4020S-4R7MCS	4.7	±20%	105	2.4	3.0	2.2	2.8
MTA4020S-6R8MCS	6.8	±20%	175	2.0	2.5	1.9	2.4
MTA4020S-100MCS	10	±20%	282	1.6	2.0	1.3	1.6
MTA4020S-220MCS	22	±20%	363	1.12	1.4	0.9	1.2

MTA5018S Electrical Characteristics

Part Number	Inductance (uH) ①	Inductance Tolerance	DCR ② (mΩ) max.	Isat ③ (A) Max.	Isat ③ (A) Typ.	Irms ④ (A) Max.	Irms ④ (A) Typ.
MTA5018S-R47MCS	0.47	±20%	9.0	9.6	12.0	9.5	10.5
MTA5018S-R56MCS	0.56	±20%	10	8.8	11.0	8.2	8.5
MTA5018S-1R0MCS	1.0	±20%	17	7.2	9.0	7.2	8.0
MTA5018S-1R5MCS	1.5	±20%	26	6.4	8.0	6.6	7.5
MTA5018S-2R2MCS	2.2	±20%	35	4.8	6.0	4.2	5.0
MTA5018S-3R3MCS	3.3	±20%	58	3.84	4.8	3.8	4.5
MTA5018S-4R7MCS	4.7	±20%	85	3.2	4.0	3.0	3.5
MTA5018S-6R8MCS	6.8	±20%	120	2.72	3.4	2.4	2.8
MTA5018S-100MCS	10	±20%	155	2.0	2.5	2.2	2.5

MTA5030S Electrical Characteristics

Part Number	Inductance (uH) ①	Inductance Tolerance	DCR ② (mΩ) max.	Isat ③ (A) Max.	Isat ③ (A) Typ.	Irms ④ (A) Max.	Irms ④ (A) Typ.
MTA5030S-R10MCS	0.10	±20%	3.0	24.0	30.0	23.0	25.0
MTA5030S-R20MCS	0.20	±20%	3.9	16.0	20.0	13.0	14.0
MTA5030S-R33MCS	0.33	±20%	5.5	14.4	18.0	13.1	14.0
MTA5030S-R47MCS	0.47	±20%	8.5	12.0	15.0	10.0	11.0
MTA5030S-R68MCS	0.68	±20%	12	9.2	11.5	8.2	9.0
MTA5030S-1R0MCS	1.0	±20%	14	8.0	10.0	7.8	8.5
MTA5030S-1R2MCS	1.2	±20%	16	7.6	9.5	7.85	8.5
MTA5030S-1R5MCS	1.5	±20%	25	7.2	9.0	7.6	8.2
MTA5030S-2R2MCS	2.2	±20%	29	5.6	7.0	6.4	7.0
MTA5030S-3R3MCS	3.3	±20%	38	4.8	6.0	5.5	5.5
MTA5030S-4R7MCS	4.7	±20%	60	3.68	4.6	4.0	4.5
MTA5030S-6R8MCS	6.8	±20%	90	2.88	3.6	2.9	3.5
MTA5030S-100MCS	10	±20%	125	2.8	3.5	2.8	3.2

All specifications are subject to change without notice.

MTA6018S Electrical Characteristics

Part Number	Inductance (uH) ①	Inductance Tolerance	DCR ② (mΩ) max.	Isat ③ (A) Max.	Isat ③ (A) Typ.	Irms ④ (A) Max.	Irms ④ (A) Typ.
MTA6018S-R10MCS	0.10	±20%	2.3	30.4	38.0	23.0	25.0
MTA6018S-R22MCS	0.22	±20%	3.5	19.2	24.0	20.0	22.0
MTA6018S-R47MCS	0.47	±20%	8.4	14.4	18.0	10.0	11.5
MTA6018S-R68MCS	0.68	±20%	12	13.2	16.5	8.4	9.5
MTA6018S-1R0MCS	1.0	±20%	16	9.6	12.0	7.6	8.5
MTA6018S-1R5MCS	1.5	±20%	26	7.36	9.2	7.1	8.0
MTA6018S-2R2MCS	2.2	±20%	35	6.4	8.0	6.2	7.0
MTA6018S-3R3MCS	3.3	±20%	50	4.8	6.0	3.8	4.5
MTA6018S-4R7MCS	4.7	±20%	62	4.0	5.0	3.5	4.0
MTA6018S-6R8MCS	6.8	±20%	110	3.6	4.5	2.4	3.0
MTA6018S-100MCS	10	±20%	155	3.2	4.0	1.95	2.3
MTA6018S-220MCS	22	±20%	350	1.84	2.3	1.4	1.8

MTA6020S Electrical Characteristics

Part Number	Inductance (uH) ①	Inductance Tolerance	DCR ② (mΩ) max.	Isat ③ (A) Max.	Isat ③ (A) Typ.	Irms ④ (A) Max.	Irms ④ (A) Typ.
MTA6020S-4R7MCS	4.7	±20%	60	4.4	5.5	3.44	4.3
MTA6020S-100MCS	10	±20%	145	3.2	4.0	2.24	2.8

MTA6024S Electrical Characteristics

Part Number	Inductance (uH) ①	Inductance Tolerance	DCR ② (mΩ) max.	Isat ③ (A) Max.	Isat ③ (A) Typ.	Irms ④ (A) Max.	Irms ④ (A) Typ.
MTA6024S-R22MCS	0.22	±20%	3.0	24.0	30.0	19.0	21.0
MTA6024S-R33MCS	0.33	±20%	4.1	19.6	24.5	16.0	18.0
MTA6024S-R47MCS	0.47	±20%	5.1	16.0	20.0	13.5	15.0
MTA6024S-R56MCS	0.56	±20%	6.5	13.6	17.0	11.5	13.0
MTA6024S-R68MCS	0.68	±20%	7.0	12.8	16.0	10.5	12.0
MTA6024S-1R0MCS	1.0	±20%	13.5	12.0	15.0	8.0	9.0
MTA6024S-1R5MCS	1.5	±20%	20	10.8	13.5	7.0	8.2
MTA6024S-2R2MCS	2.2	±20%	28	8.0	10.0	6.2	7.0
MTA6024S-3R3MCS	3.3	±20%	39	6.4	8.0	4.8	5.5
MTA6024S-4R7MCS	4.7	±20%	50	5.2	6.5	4.3	5.0
MTA6024S-6R8MCS	6.8	±20%	70	4.8	6.0	3.2	4.0
MTA6024S-100MCS	10	±20%	101	3.2	4.0	2.4	3.1
MTA6024S-150MCS	15	±20%	160	2.64	3.3	2.0	2.5
MTA6024S-220MCS	22	±20%	230	2.0	2.5	1.6	2.0

MTA6030S Electrical Characteristics

Part Number	Inductance (uH) ①	Inductance Tolerance	DCR ② (mΩ) max.	Isat ③ (A) Max.	Isat ③ (A) Typ.	Irms ④ (A) Max.	Irms ④ (A) Typ.
MTA6030S-R22MCS	0.22	±20%	3.0	27.2	34.0	21.0	24.0
MTA6030S-R33MCS	0.33	±20%	3.5	20.0	25.0	19.0	21.0
MTA6030S-R47MCS	0.47	±20%	4.1	16.0	20.0	16.5	18.0
MTA6030S-R56MCS	0.56	±20%	4.5	14.4	18.0	15.0	16.5

All specifications are subject to change without notice.

MTA6030S Electrical Characteristics

Part Number	Inductance (uH) ①	Inductance tolerance	DCR ② (mΩ) max.	I sat ③ (A) max.	I sat ③ (A) typ.	I rms ④ (A) Max.	I rms ④ (A) typ.
MTA6030S-R68MCS	0.68	±20%	5.3	13.6	17.0	14.5	16.0
MTA6030S-R82MCS	0.82	±20%	6.0	12.8	16.0	12.5	14.0
MTA6030S-1R0MCS	1.0	±20%	10	12.0	15.0	10.5	12.0
MTA6030S-1R5MCS	1.5	±20%	15	9.6	12.0	10.5	12.0
MTA6030S-2R2MCS	2.2	±20%	20	8.0	10.0	8.5	9.5
MTA6030S-3R3MCS	3.3	±20%	30	7.6	9.5	7.5	8.5
MTA6030S-4R7MCS	4.7	±20%	40	7.2	9.0	5.0	6.0
MTA6030S-5R6MCS	5.6	±20%	45	5.2	6.5	4.8	5.5
MTA6030S-6R8MCS	6.8	±20%	60	4.8	6.0	4.2	5.0
MTA6030S-8R2MCS	8.2	±20%	70	4.4	5.5	4.2	5.0
MTA6030S-100MCS	10	±20%	68	4.4	5.5	3.8	4.5
MTA6030S-150MCS	15	±20%	130	3.2	4.0	2.3	3.0
MTA6030S-220MCS	22	±20%	200	2.4	3.0	2.0	2.5
MTA6030S-330MCS	33	±20%	240	2.0	2.5	1.6	2.0
MTA6030S-470MCS	47	±20%	390	1.6	2.0	1.2	1.5

MTA6040S Electrical Characteristics

Part Number	Inductance (uH) ①	Inductance Tolerance	DCR ② (mΩ) max.	Isat ③ (A) Max.	Isat ③ (A) Typ.	Irms ④ (A) Max.	Irms ④ (A) Typ.
MTA6040S-R68MCS	0.68	±20%	4.8	15.2	19.0	13.6	17.0
MTA6040S-1R0MCS	1.0	±20%	6.6	12.8	16.0	10.8	13.5
MTA6040S-1R5MCS	1.5	±20%	10	10.0	12.5	9.92	12.4
MTA6040S-2R2MCS	2.2	±20%	14	8.8	11.0	7.8	10.0
MTA6040S-3R3MCS	3.3	±20%	20	7.6	9.5	6.8	8.5
MTA6040S-4R7MCS	4.7	±20%	30	7.2	9.0	6.0	6.5
MTA6040S-6R8MCS	6.8	±20%	45	5.2	6.5	4.4	5.5
MTA6040S-100MCS	10	±20%	65	4.8	6.0	3.84	4.8
MTA6040S-150MCS	15	±20%	95	3.6	4.5	2.8	3.7
MTA6040S-220MCS	22	±20%	125	3.2	4.0	2.64	3.3
MTA6040S-330MCS	33	±20%	240	2.4	3.0	1.76	2.2
MTA6040S-470MCS	47	±20%	320	2.0	2.5	1.44	1.8

MTA6050S Electrical Characteristics

Part Number	Inductance (uH) ①	Inductance Tolerance	DCR ② (mΩ) max.	Isat ③ (A) Max.	Isat ③ (A) Typ.	Irms ④ (A) Max.	Irms ④ (A) Typ.
MTA6050S-R47MCS	0.47	±20%	3.9	16.8	21.0	17.0	20.0
MTA6050S-R68MCS	0.68	±20%	4.5	14.4	18.0	14.5	16.5
MTA6050S-1R0MCS	1.0	±20%	6.6	12.8	16.0	10.0	12.0
MTA6050S-1R5MCS	1.5	±20%	10	10.4	13.0	8.2	9.5
MTA6050S-2R2MCS	2.2	±20%	12.5	8.8	11.0	8.0	9.0
MTA6050S-3R3MCS	3.3	±20%	22	8.0	10.0	7.6	8.5
MTA6050S-4R7MCS	4.7	±20%	29	6.4	8.0	5.0	6.0
MTA6050S-6R8MCS	6.8	±20%	41	5.04	6.3	4.0	5.8
MTA6050S-8R2MCS	8.2	±20%	48	4.4	5.5	4.8	5.5
MTA6050S-100MCS	10	±20%	60	4.24	5.3	3.8	4.5

All specifications are subject to change without notice.

MTA Series

SMD Molding Power Inductors

MTA6050S Electrical Characteristics

Part Number	Inductance (uH) ①	Inductance tolerance	DCR ② (mΩ) max.	I sat ③ (A) max.	I sat ③ (A) typ.	I rms ④ (A) Max.	I rms ④ (A) typ.
MTA6050S-150MCS	15	±20%	90	3.2	4.0	2.6	3.1
MTA6050S-220MCS	22	±20%	140	2.8	3.5	2.0	2.6
MTA6050S-330MCS	33	±20%	190	2.4	3.0	1.8	2.3
MTA6050S-470MCS	47	±20%	230	2.08	2.6	1.5	2.0
MTA6050S-680MCS	68	±20%	400	1.76	2.2	1.35	1.8

MTA8040S Electrical Characteristics

Part Number	Inductance (uH) ①	Inductance Tolerance	DCR ② (mΩ) max.	Isat ③ (A) Max.	Isat ③ (A) Typ.	Irms ④ (A) Max.	Irms ④ (A) Typ.
MTA8040S-1R0MCS	1.0	±20%	6.5	17.0	18.0	12.8	14.0
MTA8040S-2R2MCS	2.2	±20%	10.5	13.0	15.0	11.5	12.8
MTA8040S-3R3MCS	3.3	±20%	15	11.5	12.5	9.5	10.5
MTA8040S-4R7MCS	4.7	±20%	26	10.7	11.5	7.0	8.0
MTA8040S-100MCS	10	±20%	55	7.2	8.0	5.2	5.8
MTA8040S-150MCS	15	±20%	70	5.8	7.0	4.6	5.4
MTA8040S-220MCS	22	±20%	110	4.6	5.2	3.6	4.2
MTA8040S-330MCS	33	±20%	150	3.2	3.8	2.9	3.3
MTA8040S-470MCS	47	±20%	220	2.8	3.2	1.7	2.0
MTA8040S-680MCS	68	±20%	310	2.5	3.0	1.55	1.8

MTA8050S Electrical Characteristics

Part Number	Inductance (uH) ①	Inductance Tolerance	DCR ② (mΩ) max.	Isat ③ (A) Max.	Isat ③ (A) Typ.	Irms ④ (A) Max.	Irms ④ (A) Typ.
MTA8050S-1R0MCS	1.0	±20%	6.2	17.5	19.0	13.5	14.5
MTA8050S-2R2MCS	2.2	±20%	10.0	13.2	15.5	12.0	13.0
MTA8050S-3R3MCS	3.3	±20%	14.5	12.0	14.0	10.0	11.0
MTA8050S-4R7MCS	4.7	±20%	21.5	11.5	13.0	7.5	8.5
MTA8050S-100MCS	10	±20%	38	8.2	9.5	5.5	6.0
MTA8050S-150MCS	15	±20%	50	6.2	7.5	4.7	5.5
MTA8050S-220MCS	22	±20%	80	5.5	6.5	3.8	4.5
MTA8050S-330MCS	33	±20%	140	4.7	5.5	3.0	3.5
MTA8050S-470MCS	47	±20%	190	3.3	3.8	1.9	2.2
MTA8050S-680MCS	68	±20%	295	3.0	3.5	1.7	2.0
MTA8050S-101MCS	100	±20%	400	2.15	2.6	1.3	1.5

MTA1030S Electrical Characteristics

Part Number	Inductance (uH) ①	Inductance Tolerance	DCR ② (mΩ) max.	Isat ③ (A) Max.	Isat ③ (A) Typ.	Irms ④ (A) Max.	Irms ④ (A) Typ.
MTA1030S-R22MCS	0.22	±20 %	1.2	40.0	50.0	28.1	33.0
MTA1030S-R33MCS	0.33	±20 %	1.6	25.6	32.0	19.6	23.0
MTA1030S-R36MCS	0.36	±20 %	1.6	22.4	28.0	19.6	23.0
MTA1030S-R47MCS	0.47	±20 %	2.5	20.8	26.0	18.7	22.0
MTA1030S-R82MCS	0.82	±20 %	3.7	18.4	23.0	15.3	18.0
MTA1030S-1R0MCS	1.0	±20 %	6	16.8	21.0	12.8	15.0

All specifications are subject to change without notice.

MTA1030S Electrical Characteristics

Part Number	Inductance (uH) ①	Inductance tolerance	DCR ② (mΩ) max.	I sat ③ (A) max.	I sat ③ (A) typ.	I rms ④ (A) Max.	I rms ④ (A) typ.
MTA1030S-2R2MCS	2.2	±20 %	9.0	11.2	14.0	9.4	11.0
MTA1030S-3R3MCS	3.3	±20 %	16	9.6	12.0	7.7	9.0
MTA1030S-4R7MCS	4.7	±20 %	24	8.0	10.0	6.0	7.0
MTA1030S-8R2MCS	8.2	±20 %	45	5.6	7.0	4.3	5.0
MTA1030S-330MCS	33.0	±20 %	160	3.2	4.0	2.2	2.6

MTA1040S Electrical Characteristics

Part Number	Inductance (uH) ①	Inductance Tolerance	DCR ② (mΩ) max.	Isat ③ (A) Max.	Isat ③ (A) Typ.	Irms ④ (A) Max.	Irms ④ (A) Typ.
MTA1040S-R15MCS	0.15	±20%	0.7	60.0	75.0	40.0	45.0
MTA1040S-R22MCS	0.22	±20%	1.0	48.0	60.0	30.0	35.0
MTA1040S-R30MCS	0.30	±20%	1.1	36.0	45.0	30.0	35.0
MTA1040S-R36MCS	0.36	±20%	1.2	36.0	45.0	25.0	30.0
MTA1040S-R45MCS	0.45	±20%	1.5	34.0	43.0	25.0	30.0
MTA1040S-R47MCS	0.47	±20%	1.7	32.0	40.0	25.0	30.0
MTA1040S-R56MCS	0.56	±20%	1.8	26.4	33.0	20.0	25.0
MTA1040S-R68MCS	0.68	±20%	2.4	24.0	30.0	19.0	23.0
MTA1040S-R80MCS	0.80	±20%	2.7	23.2	29.0	19.0	23.0
MTA1040S-1R0MCS	1.0	±20%	3.3	22.4	28.0	16.0	19.0
MTA1040S-1R5MCS	1.5	±20%	4.2	19.2	24.0	14.0	16.0
MTA1040S-2R2MCS	2.2	±20%	7.0	13.2	16.5	10.0	12.0
MTA1040S-3R3MCS	3.3	±20%	13.5	12.8	16.0	9.5	11.0
MTA1040S-4R7MCS	4.7	±20%	20	10.4	13.0	7.5	9.0
MTA1040S-6R8MCS	6.8	±20%	25	9.6	12.0	7.0	8.5
MTA1040S-8R2MCS	8.2	±20%	27	7.2	9.0	6.8	8.0
MTA1040S-100MCS	10	±20%	30	6.8	8.5	6.9	7.8
MTA1040S-150MCS	15	±20%	45	5.6	7.0	5.6	6.5
MTA1040S-220MCS	22	±20%	66	4.4	5.5	4.2	5.0
MTA1040S-330MCS	33	±20%	92	3.84	4.8	3.8	4.4
MTA1040S-470MCS	47	±20%	145	3.1	3.5	2.8	3.3
MTA1040S-680MCS	68	±20%	195	2.4	3.0	2.0	2.5
MTA1040S-101MCS	100	±20%	315	2.3	2.8	1.7	2.0

MTA1050S Electrical Characteristics

Part Number	Inductance (uH) ①	Inductance Tolerance	DCR ② (mΩ) max.	Isat ③ (A) Max.	Isat ③ (A) Typ.	Irms ④ (A) Max.	Irms ④ (A) Typ.
MTA1050S-R22MCS	0.22	±20 %	0.8	52.0	65.0	31.5	37.0
MTA1050S-1R0MCS	1.0	±20 %	3.0	24.0	30.0	19.6	23.0
MTA1050S-1R5MCS	1.5	±20 %	3.8	20.0	25.0	17.9	21.0
MTA1050S-2R2MCS	2.2	±20 %	6.0	15.2	19.0	12.8	15.0
MTA1050S-3R3MCS	3.3	±20 %	10	12.8	16.0	11.1	13.0
MTA1050S-4R7MCS	4.7	±20 %	14	12.0	15.0	9.4	11.0
MTA1050S-5R6MCS	5.6	±20 %	17	11.2	14.0	8.1	9.5
MTA1050S-6R8MCS	6.8	±20 %	18.5	11.2	14.0	7.7	9.0
MTA1050S-100MCS	10	±20 %	28	8.0	10.0	6.8	8.0

All specifications are subject to change without notice.

MTA1050S Electrical Characteristics

Part Number	Inductance (uH) ①	Inductance tolerance	DCR ② (mΩ) max.	I sat ③ (A) max.	I sat ③ (A) typ.	I rms ④ (A) Max.	I rms ④ (A) typ.
MTA1050S-150MCS	15	±20 %	42	6.0	7.5	5.5	6.5
MTA1050S-220MCS	22	±20 %	50	4.8	6.0	4.7	5.5
MTA1050S-330MCS	33	±20 %	86	4.2	5.2	4.1	4.8
MTA1050S-470MCS	47	±20 %	127	3.6	4.5	3.1	3.7
MTA1050S-101MCS	100	±20 %	290	2.2	2.8	1.8	2.1

MTA1240S Electrical Characteristics

Part Number	Inductance (uH) ①	Inductance Tolerance	DCR ② (mΩ) max.	Isat ③ (A) Max.	Isat ③ (A) Typ.	Irms ④ (A) Max.	Irms ④ (A) Typ.
MTA1240S-R22MCS	0.22	±20%	0.9	40.0	50.0	38.0	42.0
MTA1240S-R47MCS	0.47	±20%	2.0	38.4	48.0	29.0	33.0
MTA1240S-R68MCS	0.68	±20%	3.5	37.6	47.0	24.0	28.0
MTA1240S-R82MCS	0.82	±20%	4.5	32.0	40.0	24.0	28.0
MTA1240S-1R0MCS	1.0	±20%	7.5	28.0	35.0	20.0	24.0
MTA1240S-1R5MCS	1.5	±20%	9.5	24.4	30.5	17.0	20.0
MTA1240S-2R2MCS	2.2	±20%	11.5	20.8	26.0	15.0	18.0
MTA1240S-3R3MCS	3.3	±20%	13	16.8	21.0	13.0	15.0
MTA1240S-4R7MCS	4.7	±20%	14.5	14.4	18.0	11.0	13.0
MTA1240S-6R8MCS	6.8	±20%	20	11.2	14.0	8.0	9.0
MTA1240S-100MCS	10	±20%	25	8.0	10.0	7.0	8.0
MTA1240S-150MCS	15	±20%	39	6.0	7.5	5.8	6.5
MTA1240S-220MCS	22	±20%	51	4.8	6.0	3.8	4.5

MTA1250S Electrical Characteristics

Part Number	Inductance (uH) ①	Inductance Tolerance	DCR ② (mΩ) max.	Isat ③ (A) Max.	Isat ③ (A) Typ.	Irms ④ (A) Max.	Irms ④ (A) Typ.
MTA1250S-R22MCS	0.22	±20%	0.7	60.0	75.0	45.0	50.0
MTA1250S-R36MCS	0.36	±20%	0.85	40.0	50.0	37.0	42.0
MTA1250S-R50MCS	0.50	±20%	1.15	38.4	48.0	33.0	38.0
MTA1250S-R68MCS	0.68	±20%	1.55	36.8	46.0	29.0	33.0
MTA1250S-R82MCS	0.82	±20%	1.67	31.2	39.0	26.0	30.0
MTA1250S-1R0MCS	1.0	±20%	4.0	28.0	35.0	22.0	26.0
MTA1250S-1R5MCS	1.5	±20%	4.5	26.4	33.0	19.0	23.0
MTA1250S-2R2MCS	2.2	±20%	5.0	19.2	24.0	13.0	15.0
MTA1250S-3R3MCS	3.3	±20%	7.0	17.6	22.0	12.0	14.0
MTA1250S-4R7MCS	4.7	±20%	15	16.0	20.0	11.0	13.0
MTA1250S-6R8MCS	6.8	±20%	18	12.8	16.0	10.0	12.0
MTA1250S-100MCS	10	±20%	22	9.6	12.0	8.0	9.0
MTA1250S-150MCS	15	±20%	30	8.0	10.0	7.0	8.0
MTA1250S-220MCS	22	±20%	58	5.2	6.5	3.8	4.5
MTA1250S-330MCS	33	±20%	84	4.8	6.0	2.8	3.5
MTA1250S-470MCS	47	±20%	130	4.0	5.0	2.6	3.0

All specifications are subject to change without notice.

MTA1260S Electrical Characteristics

Part Number	Inductance (uH) ①	Inductance Tolerance	DCR ② (mΩ) max.	Isat ③ (A) Max.	Isat ③ (A) Typ.	Irms ④ (A) Max.	Irms ④ (A) Typ.
MTA1260S-1R5MCS	1.5	±20%	2.9	23.2	29.0	22.6	27.5
MTA1260S-2R2MCS	2.2	±20%	4.2	22.4	28.0	18.0	22.0
MTA1260S-3R3MCS	3.3	±20%	7.1	16.8	21.0	14.0	17.0
MTA1260S-4R7MCS	4.7	±20%	9.0	19.2	24.0	12.0	15.0
MTA1260S-5R6MCS	5.6	±20%	11	18.0	22.5	11.0	13.0
MTA1260S-6R8MCS	6.8	±20%	13.5	15.2	19.0	10.0	12.0
MTA1260S-8R2MCS	8.2	±20%	16	10.8	13.5	9.0	11.0
MTA1260S-100MCS	10	±20%	20.7	11.1	12.5	8.5	10.0
MTA1260S-120MCS	12	±20%	23	8.0	10.0	7.8	9.0
MTA1260S-150MCS	15	±20%	29.	7.2	9.0	7.5	8.5
MTA1260S-180MCS	18	±20%	35	6.4	8.0	6.5	7.5
MTA1260S-220MCS	22	±20%	39.5	6.0	7.5	6.0	7.0
MTA1260S-270MCS	27	±20%	56	5.2	6.5	5.0	6.0
MTA1260S-330MCS	33	±20%	75	4.8	6.0	4.8	5.5
MTA1260S-470MCS	47	±20%	90	4.4	5.5	4.2	5.0
MTA1260S-680MCS	68	±20%	140	3.6	4.5	3.2	4.0
MTA1260S-101MCS	100	±20%	200	2.8	3.5	2.5	3.0
MTA1260S-121MCS	120	±20%	235	2.56	3.2	1.7	2.0
MTA1260S-151MCS	150	±20%	350	2.16	2.7	1.2	1.5

MTA1265S Electrical Characteristics

Part Number	Inductance (uH) ①	Inductance Tolerance	DCR ② (mΩ) max.	Isat ③ (A) Max.	Isat ③ (A) Typ.	Irms ④ (A) Max.	Irms ④ (A) Typ.
MTA1265S-4R7MCS	4.7	±20%	8.5	19.2	24.0	12.8	16.0
MTA1265S-5R6MCS	5.6	±20%	10.5	18.0	22.5	11.2	14.0
MTA1265S-6R8MCS	6.8	±20%	12	15.2	19.0	10.4	13.0
MTA1265S-8R2MCS	8.2	±20%	14	12.8	16.0	9.6	12.0
MTA1265S-100MCS	10	±20%	18	12.0	15.0	8.8	11.0
MTA1265S-150MCS	15	±20%	28	8.8	11.0	7.6	9.5
MTA1265S-220MCS	22	±20%	40	7.2	9.0	6.4	8.0
MTA1265S-330MCS	33	±20%	75	6.4	8.0	5.2	6.5
MTA1265S-470MCS	47	±20%	85	5.44	6.8	4.4	5.5
MTA1265S-680MCS	68	±20%	120	4.16	5.2	3.84	4.8
MTA1265S-820MCS	82	±20%	135	3.6	4.5	3.2	4.0
MTA1265S-101MCS	100	±20%	170	3.2	4.0	2.8	3.5

① Inductance tested at 100kHz, 0.5 Vrms using an Agilent/HP 4192A or equivalent.

② DCR measured on a micro-ohmmeter.

③ Isat: The DC current at which the inductance decreases by 30% of it's initial value.

④ Irms: The DC current at which $\Delta t=40^{\circ}\text{C}$.

MTA1707S Electrical Characteristics

Part Number	Inductance (uH) ①	Inductance Tolerance	DCR ② (mΩ) max.	Isat ③ (A) Max.	Isat ③ (A) Typ.	Irms ④ (A) Max.	Irms ④ (A) Typ.
MTA1707S-2R2MCS	2.2	±20%	2.5	27.2	34.0	23.2	29.0
MTA1707S-3R3MCS	3.3	±20%	4.0	24.0	30.0	19.2	24.0
MTA1707S-4R7MCS	4.7	±20%	4.8	19.2	24.0	16.8	21.0
MTA1707S-6R8MCS	6.8	±20%	7.5	17.6	22.0	13.6	17.0
MTA1707S-8R2MCS	8.2	±20%	8.7	16.0	20.0	10.4	13.0
MTA1707S-100MCS	10	±20%	9.9	15.2	19.0	9.6	12.0
MTA1707S-150MCS	15	±20%	17	11.6	14.5	8.8	11.0
MTA1707S-220MCS	22	±20%	23	9.2	11.5	6.8	8.5
MTA1707S-330MCS	33	±20%	37	8.0	10.0	6.4	8.0
MTA1707S-470MCS	47	±20%	47	6.0	7.5	4.8	6.0
MTA1707S-680MCS	68	±20%	85	5.2	6.5	4.16	5.2
MTA1707S-101MCS	100	±20%	130	4.0	5.0	2.96	3.7

- ① Inductance tested at 100kHz, 0.5 Vrms using an Agilent/HP 4192A or equivalent.
- ② DCR measured on a micro-ohmmeter.
- ③ Isat: The DC current at which the inductance decreases by 30% of its initial value.
- ④ Irms: The DC current at which $\Delta t=40^{\circ}\text{C}$.

Product outline

- Magnetically shielded types.
- A wide range of product line up is available to meet various requirements.
- Excellent saturation current handling to be up to 9.69A.
- For DC/DC converter applications.
- Ideally used in car navigation, LED Lighting, Notebook PC, power modules, etc.
- Custom design is also available.

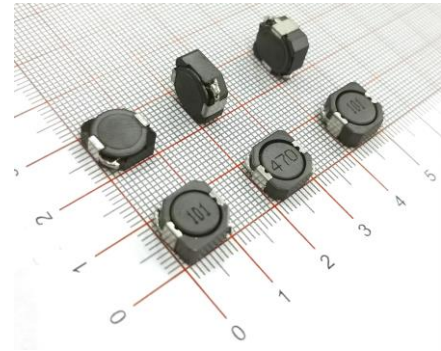

Dimensions(mm)

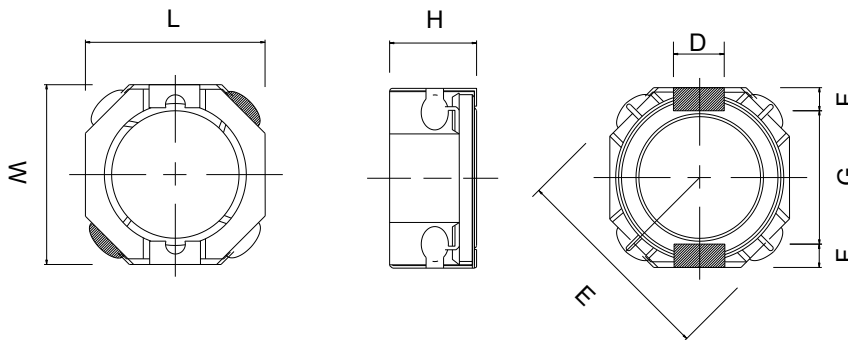

Recommended Patterns

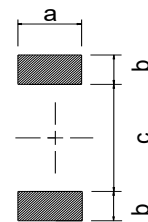

Type	L	W	H	D	E	F	G	a	b	c	Packaging (pcs/reel)
KTDRH103R	10.2±0.3	10.0±0.3	3.1 max.	3.0±0.3	13.3	1.2	7.8	3.2	1.6	7.3	1000
KTDRH104R	10.2±0.3	10.0±0.3	4.0 max.	3.0±0.3	13.3	1.2	7.8	3.2	1.6	7.3	1000
KTDRH105R	10.2±0.3	10.0±0.3	5.1 max.	3.0±0.3	13.3	1.2	7.8	3.2	1.6	7.3	800

Dimensions without tolerance are typical.

Product Identification

KTDRH 103 R - 470 N C S
 ① ② ③ ④ ⑤ ⑥ ⑦

- ① Product Series No.
- ② Dimension symbol. 103=10.2x10x3.1mm (L x W x H)
- ③ Internal control code.
- ④ Inductance value: 100=10×10⁰ uH=10uH, 2R2=2.2 uH, 472=4700uH
- ⑤ Tolerance: K=±10%, M=±20%, N=±30%
- ⑥ Packing Style: C=Carrier Tape, B=Bulk
- ⑦ Characteristic parameter level.

KTDRH10 Series SMD Power Inductors



KTDRH103R Electrical Characteristics

Part Number	Inductance (uH) ①	Inductance tolerance	Test Conditions	DCR max. (mΩ) ②	Rated current (A) ③
KTDRH103R-2R2NCS	2.2	±30%	100kHz/0.5V	23	6.50
KTDRH103R-3R3NCS	3.3	±30%	100kHz/0.5V	28	6.00
KTDRH103R-4R7NCS	4.7	±30%	100kHz/0.5V	47	5.50
KTDRH103R-6R8NCS	6.8	±30%	100kHz/0.5V	58	3.84
KTDRH103R-8R2NCS	8.2	±30%	100kHz/0.5V	72	4.50
KTDRH103R-100MCS	10	±20%	100kHz/0.5V	97	3.18
KTDRH103R-150MCS	15	±20%	100kHz/0.5V	122	2.80
KTDRH103R-220MCS	22	±20%	100kHz/0.5V	143	2.40
KTDRH103R-330MCS	33	±20%	100kHz/0.5V	230	2.20
KTDRH103R-470MCS	47	±20%	100kHz/0.5V	341	1.90
KTDRH103R-680MCS	68	±20%	100kHz/0.5V	511	1.50
KTDRH103R-820MCS	82	±20%	100kHz/0.5V	541	1.30
KTDRH103R-101MCS	100	±20%	1kHz/0.5V	803	1.10
KTDRH103R-151MCS	150	±20%	1kHz/0.5V	1260	0.92
KTDRH103R-221MCS	220	±20%	1kHz/0.5V	1760	0.75

KTDRH 104R Electrical Characteristics

Part Number	Inductance (uH) ①	Inductance tolerance	Test Conditions	DCR max. (mΩ) ②	Rated current (A) ③
KTDRH104R-1R0NCS	1.0	±30%	100kHz/0.5V	14	10.0
KTDRH104R-1R5NCS	1.5	±30%	100kHz/0.5V	47	10.0
KTDRH104R-1R8NCS	1.8	±30%	100kHz/0.5V	17	10.0
KTDRH104R-2R0NCS	2.0	±30%	100kHz/0.5V	21	7.50
KTDRH104R-2R2NCS	2.2	±30%	100kHz/0.5V	21	7.50
KTDRH104R-2R5NCS	2.5	±30%	100kHz/0.5V	21	7.50
KTDRH104R-3R3NCS	3.3	±30%	100kHz/0.5V	25	6.00
KTDRH104R-3R5NCS	3.5	±30%	100kHz/0.5V	25	6.00
KTDRH104R-3R8NCS	3.8	±30%	100kHz/0.5V	25	6.00
KTDRH104R-4R7NCS	4.7	±30%	100kHz/0.5V	28	5.50
KTDRH104R-5R2NCS	5.2	±30%	100kHz/0.5V	22	5.50
KTDRH104R-5R6NCS	5.6	±30%	100kHz/0.5V	31	5.20
KTDRH104R-6R0NCS	6.0	±30%	100kHz/0.5V	35	5.00
KTDRH104R-6R8NCS	6.8	±30%	100kHz/0.5V	38	4.80
KTDRH104R-7R0NCS	7.0	±30%	100kHz/0.5V	38	4.80
KTDRH104R-8R2NCS	8.2	±30%	100kHz/0.5V	42	4.60
KTDRH104R-100MCS	10	±20%	100kHz/0.5V	43	4.40
KTDRH104R-120MCS	12	±20%	100kHz/0.5V	60	4.00
KTDRH104R-150MCS	15	±20%	100kHz/0.5V	68	3.60
KTDRH104R-180MCS	18	±20%	100kHz/0.5V	70	3.30
KTDRH104R-220MCS	22	±20%	100kHz/0.5V	90	2.90
KTDRH104R-240MCS	24	±20%	100kHz/0.5V	110	2.90
KTDRH104R-270MCS	27	±20%	100kHz/0.5V	117	2.60
KTDRH104R-330MCS	33	±20%	100kHz/0.5V	120	2.40
KTDRH104R-390MCS	39	±20%	100kHz/0.5V	150	2.20
KTDRH104R-470MCS	47	±20%	100kHz/0.5V	190	2.10
KTDRH104R-500MCS	50	±20%	100kHz/0.5V	200	2.00
KTDRH104R-560MCS	56	±20%	100kHz/0.5V	297	1.80
KTDRH104R-680MCS	68	±20%	100kHz/0.5V	350	1.50
KTDRH104R-750MCS	75	±20%	100kHz/0.5V	365	1.47
KTDRH104R-820MCS	82	±20%	100kHz/0.5V	385	1.45
KTDRH104R-101MCS	100	±20%	1kHz/0.5V	430	1.35

All specifications are subject to change without notice.

KTDRH 104R Electrical Characteristics

Part Number	Inductance (uH) ①	Inductance tolerance	Test Conditions	DCR max. (mΩ) ②	Rated current (A) ③
KTDRH104R-121MCS	120	±20%	1kHz/0.5V	470	1.25
KTDRH104R-151MCS	150	±20%	1kHz/0.5V	506	1.15
KTDRH104R-181MCS	180	±20%	1kHz/0.5V	627	1.00
KTDRH104R-221MCS	220	±20%	1kHz/0.5V	756	0.92
KTDRH104R-271MCS	270	±20%	1kHz/0.5V	950	0.75
KTDRH104R-331MCS	330	±20%	1kHz/0.5V	1090	0.70
KTDRH104R-471MCS	470	±20%	1kHz/0.5V	1900	0.60
KTDRH104R-681MCS	680	±20%	1kHz/0.5V	2200	0.55
KTDRH104R-751MCS	750	±20%	1kHz/0.5V	3120	0.47
KTDRH104R-821MCS	820	±20%	1kHz/0.5V	4600	0.40
KTDRH104R-102MCS	1000	±20%	1kHz/0.5V	5110	0.32

KTDRH 105R Electrical Characteristics

Part Number	Inductance (uH) ①	Inductance tolerance	Test Conditions	DCR max. (mΩ) ②	Rated current (A) ③
KTDRH105R-1R5NCS	1.5	±30%	100kHz/0.5V	11	10.5
KTDRH105R-2R2NCS	2.2	±30%	100kHz/0.5V	13	9.25
KTDRH105R-3R3NCS	3.3	±30%	100kHz/0.5V	17	7.80
KTDRH105R-4R7NCS	4.7	±30%	100kHz/0.5V	19	6.40
KTDRH105R-5R6NCS	5.6	±30%	100kHz/0.5V	22	5.90
KTDRH105R-6R8NCS	6.8	±30%	100kHz/0.5V	25	5.40
KTDRH105R-8R2NCS	8.2	±30%	100kHz/0.5V	29	4.85
KTDRH105R-100MCS	10	±20%	100kHz/0.5V	46	4.50
KTDRH105R-150MCS	15	±20%	100kHz/0.5V	49	3.60
KTDRH105R-220MCS	22	±20%	100kHz/0.5V	61	2.95
KTDRH105R-330MCS	33	±20%	100kHz/0.5V	84	2.40
KTDRH105R-470MCS	47	±20%	100kHz/0.5V	130	2.00
KTDRH105R-560MCS	56	±20%	100kHz/0.5V	149	1.90
KTDRH105R-680MCS	68	±20%	100kHz/0.5V	201	1.65
KTDRH105R-820MCS	82	±20%	100kHz/0.5V	227	1.50
KTDRH105R-101MCS	100	±20%	1kHz/0.5V	253	1.35
KTDRH105R-121MCS	120	±20%	1kHz/0.5V	303	1.28
KTDRH105R-151MCS	150	±20%	1kHz/0.5V	370	1.20
KTDRH105R-181MCS	180	±20%	1kHz/0.5V	419	1.04
KTDRH105R-221MCS	220	±20%	1kHz/0.5V	500	0.94
KTDRH105R-331MCS	330	±20%	1kHz/0.5V	700	0.80
KTDRH105R-391MCS	390	±20%	1kHz/0.5V	800	0.75
KTDRH105R-471MCS	470	±20%	1kHz/0.5V	1290	0.60
KTDRH105R-561MCS	560	±20%	1kHz/0.5V	1430	0.54
KTDRH105R-681MCS	680	±20%	1kHz/0.5V	1600	0.52
KTDRH105R-821MCS	820	±20%	1kHz/0.5V	1770	0.50
KTDRH105R-102MCS	1000	±20%	1kHz/0.5V	1990	0.48
KTDRH105R-152MCS	1500	±20%	1kHz/0.5V	3050	0.40
KTDRH105R-222MCS	2200	±20%	1kHz/0.5V	5110	0.30
KTDRH105R-332MCS	3300	±20%	1kHz/0.5V	6000	0.25
KTDRH105R-472MCS	4700	±20%	1kHz/0.5V	7500	0.20

① Inductance tested using an Agilent/HP 4192A or equivalent.

② DCR measured on a micro-ohmmeter.

③ Rated current: the DC current at which the inductance decreases by 35% of its nominal value or at which $\Delta t=40^{\circ}\text{C}$, whichever is lower ($T_a=20^{\circ}\text{C}$).

Product Outline

- Magnetically shielded types.
- A wide range of product line up allows for various requirements.
- Excellent saturation current handling to be up to 19.9A.
- For DC/DC converter applications.
- Ideally used in thin-screen TV, LCDs, AV equipment, car navigations, Notebook PC and other electronic devices.
- Custom design is also available.
- RoHS compliant.

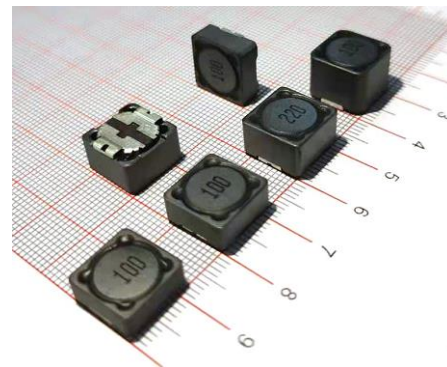

Dimensions(mm)

Recommended Land Patterns

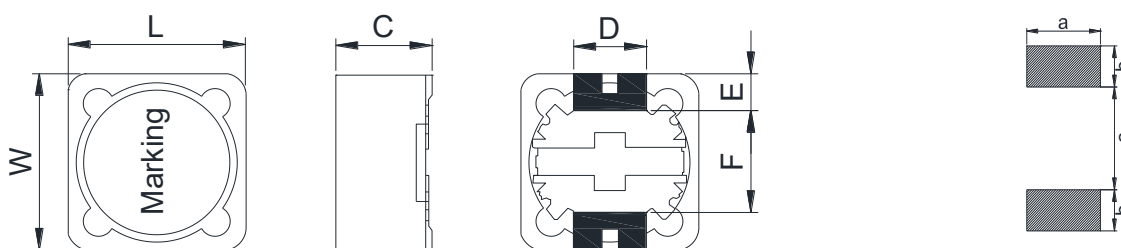

Type	L	W	C	D	E	F	a	b	c	Packaging (pcs/reel)
KTDRH124S	12.2±0.4	12.2±0.4	4.5±0.3	5.0	2.2	7.6	5.4	2.8	7.0	500
KTDRH125S	12.2±0.4	12.2±0.4	5.7±0.3	5.0	2.2	7.6	5.4	2.8	7.0	500
KTDRH127S	12.2±0.4	12.2±0.4	7.5±0.3	5.0	2.2	7.6	5.4	2.8	7.0	500
KTDRH129S	12.2±0.4	12.2±0.4	9.5±0.3	5.0	2.2	7.6	5.4	2.8	7.0	350

Dimensions without tolerance are typical.

Product Identification

KTDRH **127** **S** - **470** **N** **C** **S**
 ① ② ③ ④ ⑤ ⑥ ⑦

- ① Product Series No.
- ② Dimension symbol: 124=12.2 x 12.2 x 4.5mm (L x W x H)
- ③ Internal control code.
- ④ Inductance value: 100=10×10⁰ uH=10uH , 2R2=2.2uH, 101=100uH, 102=1000uH
- ⑤ Tolerance: M=±20%, N=±30%, K=±10%
- ⑥ Packing Style: C=Carrier Tape, B=Bulk
- ⑦ Characteristic parameter level.

KTDRH124S Electrical Characteristics

Part Number	Inductance (uH) ①	Inductance tolerance	Test Frequency	DCR max. (mΩ) ②	Rated current (A) ③
KTDRH124S-1R0NCS	1.0	±30%	100kHz/0.5V	8	12.00
KTDRH124S-1R6NCS	1.6	±30%	100kHz/0.5V	9	8.00
KTDRH124S-3R9NCS	3.9	±30%	100kHz/0.5V	18	6.50
KTDRH124S-4R7NCS	4.7	±30%	100kHz/0.5V	22	5.70
KTDRH124S-6R8NCS	6.8	±30%	100kHz/0.5V	28	4.90
KTDRH124S-100MCS	10	±20%	100kHz/0.5V	35	4.50
KTDRH124S-120MCS	12	±20%	100kHz/0.5V	38	4.00
KTDRH124S-150MCS	15	±20%	100kHz/0.5V	50	3.20
KTDRH124S-180MCS	18	±20%	100kHz/0.5V	57	3.10
KTDRH124S-220MCS	22	±20%	100kHz/0.5V	66	2.90
KTDRH124S-270MCS	27	±20%	100kHz/0.5V	80	2.80
KTDRH124S-300MCS	30	±20%	100kHz/0.5V	90	2.75
KTDRH124S-330MCS	33	±20%	100kHz/0.5V	97	2.70
KTDRH124S-390MCS	39	±20%	100kHz/0.5V	132	2.10
KTDRH124S-470MCS	47	±20%	100kHz/0.5V	150	1.90
KTDRH124S-560MCS	56	±20%	100kHz/0.5V	190	1.80
KTDRH124S-680MCS	68	±20%	100kHz/0.5V	220	1.50
KTDRH124S-820MCS	82	±20%	100kHz/0.5V	260	1.30
KTDRH124S-101MCS	100	±20%	1kHz/0.5V	308	1.20
KTDRH124S-121MCS	120	±20%	1kHz/0.5V	380	1.10
KTDRH124S-151MCS	150	±20%	1kHz/0.5V	530	0.95
KTDRH124S-181MCS	180	±20%	1kHz/0.5V	620	0.85
KTDRH124S-221MCS	220	±20%	1kHz/0.5V	700	0.80
KTDRH124S-271MCS	270	±20%	1kHz/0.5V	876	0.60
KTDRH124S-331MCS	330	±20%	1kHz/0.5V	990	0.50
KTDRH124S-471MCS	470	±20%	1kHz/0.5V	1300	0.40
KTDRH124S-152MCS	1500	±20%	1kHz/0.5V	4000	0.29

① Inductance tested using an Agilent/HP 4192A or equivalent.

② DCR measured on a micro-ohmmeter.

③ Rated current: the DC current at which the inductance decreases by 20% of its nominal value or at which $\Delta t=40^{\circ}\text{C}$, whichever is lower ($T_a=20^{\circ}\text{C}$).

KTDRH125S Electrical Characteristics

Part Number	Inductance (uH) ①	Inductance tolerance	Test Frequency	DCR max. (mΩ) ②	Rated current (A) ③
KTDRH125S-1R3MCS	1.3	±20%	100kHz/0.5V	12	8.00
KTDRH125S-2R1MCS	2.1	±20%	100kHz/0.5V	14	7.00
KTDRH125S-2R2MCS	2.2	±20%	100kHz/0.5V	14	7.00
KTDRH125S-3R1MCS	3.1	±20%	100kHz/0.5V	17	6.00
KTDRH125S-3R9MCS	3.9	±20%	100kHz/0.5V	18	5.50
KTDRH125S-4R4MCS	4.4	±20%	100kHz/0.5V	20	5.00
KTDRH125S-4R7MCS	4.7	±20%	100kHz/0.5V	20	5.00
KTDRH125S-5R8MCS	5.8	±20%	100kHz/0.5V	21	4.40
KTDRH125S-6R8MCS	6.8	±20%	100kHz/0.5V	22	3.00
KTDRH125S-7R5MCS	7.5	±20%	100kHz/0.5V	24	4.20
KTDRH125S-8R2MCS	8.2	±20%	100kHz/0.5V	25	4.00
KTDRH125S-100MCS	10	±20%	100kHz/0.5V	25	4.00
KTDRH125S-120MCS	12	±20%	100kHz/0.5V	27	3.50
KTDRH125S-150MCS	15	±20%	100kHz/0.5V	30	3.30
KTDRH125S-180MCS	18	±20%	100kHz/0.5V	34	3.00
KTDRH125S-220MCS	22	±20%	100kHz/0.5V	42	2.80
KTDRH125S-270MCS	27	±20%	100kHz/0.5V	51	2.30
KTDRH125S-330MCS	33	±20%	100kHz/0.5V	65	2.10
KTDRH125S-390MCS	39	±20%	100kHz/0.5V	68	2.00
KTDRH125S-470MCS	47	±20%	100kHz/0.5V	75	1.80
KTDRH125S-560MCS	56	±20%	100kHz/0.5V	110	1.70
KTDRH125S-680MCS	68	±20%	100kHz/0.5V	120	1.50
KTDRH125S-820MCS	82	±20%	100kHz/0.5V	140	1.40
KTDRH125S-101MCS	100	±20%	1kHz/0.5V	198	1.30
KTDRH125S-121MCS	120	±20%	1kHz/0.5V	220	1.10
KTDRH125S-151MCS	150	±20%	1kHz/0.5V	230	1.00
KTDRH125S-181MCS	180	±20%	1kHz/0.5V	290	0.90
KTDRH125S-221MCS	220	±20%	1kHz/0.5V	400	0.80
KTDRH125S-271MCS	270	±20%	1kHz/0.5V	460	0.75
KTDRH125S-331MCS	330	±20%	1kHz/0.5V	510	0.68
KTDRH125S-391MCS	390	±20%	1kHz/0.5V	690	0.65
KTDRH125S-471MCS	470	±20%	1kHz/0.5V	770	0.58
KTDRH125S-561MCS	560	±20%	1kHz/0.5V	860	0.54
KTDRH125S-681MCS	680	±20%	1kHz/0.5V	1200	0.48
KTDRH125S-821MCS	820	±20%	1kHz/0.5V	1340	0.43
KTDRH125S-102MCS	1000	±20%	1kHz/0.5V	1900	0.40
KTDRH125S-472MCS	4700	±20%	1kHz/0.5V	8280	0.30
KTDRH125S-802MCS	8000	±20%	1kHz/0.5V	15000	0.22
KTDRH125S-103MCS	10000	±20%	1kHz/0.5V	20000	0.12

① Inductance tested using an Agilent/HP 4192A or equivalent.

② DCR measured on a micro-ohmmeter.

③ Rated current: the DC current at which the inductance decreases by 20% of its nominal value or at which $\Delta t=40^{\circ}\text{C}$, whichever is lower ($T_a=20^{\circ}\text{C}$).

KTDRH127S Electrical Characteristics

Part Number	Inductance (uH) ①	Inductance tolerance	Test Frequency	DCR max. (mΩ) ②	Rated current (A) ③
KTDRH127S-1R0NCS	1.0	±30%	100kHz/0.5V	7	9.80
KTDRH127S-1R5NCS	1.5	±30%	100kHz/0.5V	10	9.00
KTDRH127S-2R2NCS	2.2	±30%	100kHz/0.5V	11.5	7.50
KTDRH127S-2R4NCS	2.4	±30%	100kHz/0.5V	11.5	8.00
KTDRH127S-2R5NCS	2.5	±30%	100kHz/0.5V	11.5	7.50
KTDRH127S-3R3NCS	3.3	±30%	100kHz/0.5V	13.5	7.50
KTDRH127S-3R5NCS	3.5	±30%	100kHz/0.5V	13.5	7.50
KTDRH127S-4R7NCS	4.7	±30%	100kHz/0.5V	15.8	6.80
KTDRH127S-5R6NCS	5.6	±30%	100kHz/0.5V	17.6	6.70
KTDRH127S-6R1NCS	6.1	±30%	100kHz/0.5V	17.6	6.60
KTDRH127S-6R8NCS	6.8	±30%	100kHz/0.5V	20	6.60
KTDRH127S-7R6NCS	7.6	±30%	100kHz/0.5V	20	5.90
KTDRH127S-8R2NCS	8.2	±30%	100kHz/0.5V	25	5.90
KTDRH127S-100MCS	10	±20%	100kHz/0.5V	21.6	5.40
KTDRH127S-120MCS	12	±20%	100kHz/0.5V	24.3	4.90
KTDRH127S-150MCS	15	±20%	100kHz/0.5V	27	4.50
KTDRH127S-180MCS	18	±20%	100kHz/0.5V	39.2	3.90
KTDRH127S-220MCS	22	±20%	100kHz/0.5V	43.2	3.60
KTDRH127S-250MCS	25	±20%	100kHz/0.5V	45.9	3.40
KTDRH127S-270MCS	27	±20%	100kHz/0.5V	45.9	3.40
KTDRH127S-330MCS	33	±20%	100kHz/0.5V	64.8	3.20
KTDRH127S-390MCS	39	±20%	100kHz/0.5V	72.9	2.75
KTDRH127S-400MCS	40	±20%	100kHz/0.5V	79	2.75
KTDRH127S-470MCS	47	±20%	100kHz/0.5V	100	2.50
KTDRH127S-500MCS	50	±20%	100kHz/0.5V	73	3.00
KTDRH127S-560MCS	56	±20%	100kHz/0.5V	110	2.35
KTDRH127S-680MCS	68	±20%	100kHz/0.5V	140	2.10
KTDRH127S-820MCS	82	±20%	100kHz/0.5V	160	1.95
KTDRH127S-101MCS	100	±20%	1kHz/0.5V	220	1.70
KTDRH127S-121MCS	120	±20%	1kHz/0.5V	250	1.60
KTDRH127S-151MCS	150	±20%	1kHz/0.5V	280	1.42
KTDRH127S-181MCS	180	±20%	1kHz/0.5V	350	1.30
KTDRH127S-221MCS	220	±20%	1kHz/0.5V	390	1.16
KTDRH127S-271MCS	270	±20%	1kHz/0.5V	560	1.06
KTDRH127S-331MCS	330	±20%	1kHz/0.5V	640	0.95
KTDRH127S-391MCS	390	±20%	1kHz/0.5V	700	0.88
KTDRH127S-471MCS	470	±20%	1kHz/0.5V	980	0.79
KTDRH127S-561MCS	560	±20%	1kHz/0.5V	1070	0.73
KTDRH127S-681MCS	680	±20%	1kHz/0.5V	1460	0.67
KTDRH127S-821MCS	820	±20%	1kHz/0.5V	1640	0.60
KTDRH127S-102MCS	1000	±20%	1kHz/0.5V	1820	0.55
KTDRH127S-152MCS	1500	±20%	1kHz/0.5V	2400	0.50
KTDRH127S-222MCS	2200	±20%	1kHz/0.5V	2950	0.30

All specifications are subject to change without notice.

KTDRH129S Electrical Characteristics

Part Number	Inductance (uH) ①	Inductance tolerance	Test Frequency	DCR max. (mΩ) ②	Rated current (A) ③
KTDRH129S-1R0NCS	1.0	±30%	100kHz/0.5V	6	19.90
KTDRH129S-1R5NCS	1.5	±30%	100kHz/0.5V	7	13.40
KTDRH129S-1R8NCS	1.8	±30%	100kHz/0.5V	7	13.40
KTDRH129S-2R2NCS	2.2	±30%	100kHz/0.5V	8	12.16
KTDRH129S-3R3NCS	3.3	±30%	100kHz/0.5V	10	12.00
KTDRH129S-4R7NCS	4.7	±30%	100kHz/0.5V	11	10.08
KTDRH129S-5R6NCS	5.6	±30%	100kHz/0.5V	13	9.30
KTDRH129S-6R8NCS	6.8	±30%	100kHz/0.5V	14	8.56
KTDRH129S-7R5NCS	7.5	±30%	100kHz/0.5V	17	8.48
KTDRH129S-8R2NCS	8.2	±30%	100kHz/0.5V	17	8.48
KTDRH129S-100MCS	10	±20%	100kHz/0.5V	18	7.12
KTDRH129S-120MCS	12	±20%	100kHz/0.5V	23	7.04
KTDRH129S-150MCS	15	±20%	100kHz/0.5V	28	5.84
KTDRH129S-220MCS	22	±20%	100kHz/0.5V	41	5.12
KTDRH129S-330MCS	33	±20%	100kHz/0.5V	44	4.25
KTDRH129S-470MCS	47	±20%	100kHz/0.5V	80	3.60
KTDRH129S-560MCS	56	±20%	100kHz/0.5V	91	2.85
KTDRH129S-680MCS	68	±20%	100kHz/0.5V	98	2.76
KTDRH129S-820MCS	82	±20%	100kHz/0.5V	138	2.62
KTDRH129S-101MCS	100	±20%	1kHz/0.5V	140	2.50
KTDRH129S-121MCS	120	±20%	1kHz/0.5V	169	2.05
KTDRH129S-151MCS	150	±20%	1kHz/0.5V	245	1.80
KTDRH129S-181MCS	180	±20%	1kHz/0.5V	270	1.66
KTDRH129S-221MCS	220	±20%	1kHz/0.5V	306	1.64
KTDRH129S-331MCS	330	±20%	1kHz/0.5V	488	1.28
KTDRH129S-471MCS	470	±20%	1kHz/0.5V	599	1.06
KTDRH129S-561MCS	560	±20%	1kHz/0.5V	887	1.01
KTDRH129S-681MCS	680	±20%	1kHz/0.5V	1003	0.83
KTDRH129S-821MCS	820	±20%	1kHz/0.5V	1108	0.81
KTDRH129S-102MCS	1000	±20%	1kHz/0.5V	1200	0.75

① Inductance tested using an Agilent/HP 4192A or equivalent.

② DCR measured on a micro-ohmmeter.

③ Rated current: the DC current at which the inductance decreases by 20% of its nominal value or at which $\Delta t=40^{\circ}\text{C}$, whichever is lower ($T_a=20^{\circ}\text{C}$).

KTDRH74S Series SMD Power Inductors

Product outline

- Magnetically shielded types.
- A wide range of product line up is available to meet various requirements.
- Excellent saturation current handling to be up to 1.84A.
- For DC/DC converter applications.
- Ideally used in car navigation, LED Lighting, Notebook PC, power modules, etc.
- Custom design is also available.

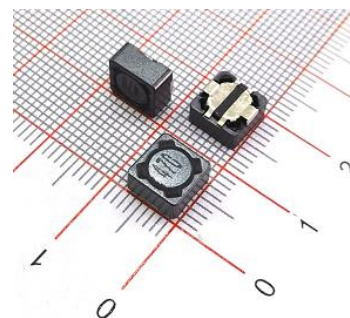

Dimensions(mm)

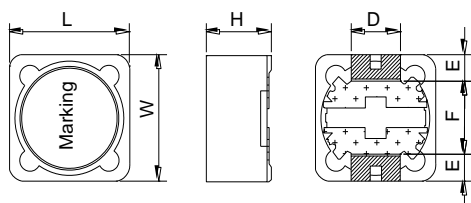

Recommended Patterns

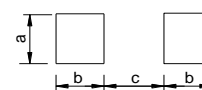

Type	L	W	H	D	E	F	a	b	c	Packaging (pcs/reel)
KTDRH74S	7.8 Max	7.8 Max	5.0 Max	1.8	1.0	5.4	2.2	1.6	4.8	1000

Dimensions without tolerance are typical.

Electrical Characteristics

Part Number	Inductance-L (uH)	Inductance tolerance	Test Conditions	DCR max. (mΩ) ①	Rated current (A) ②
KTDRH74S-100MCS	10	±20%	100kHz/0.5V	49	1.84
KTDRH74S-120MCS	12	±20%	100kHz/0.5V	58	1.71
KTDRH74S-150MCS	15	±20%	100kHz/0.5V	81	1.47
KTDRH74S-180MCS	18	±20%	100kHz/0.5V	91	1.31
KTDRH74S-220MCS	22	±20%	100kHz/0.5V	110	1.23
KTDRH74S-270MCS	27	±20%	100kHz/0.5V	150	1.12
KTDRH74S-330MCS	33	±20%	100kHz/0.5V	170	0.96
KTDRH74S-390MCS	39	±20%	100kHz/0.5V	230	0.91
KTDRH74S-470MCS	47	±20%	100kHz/0.5V	260	0.88
KTDRH74S-560MCS	56	±20%	100kHz/0.5V	350	0.75
KTDRH74S-680MCS	68	±20%	100kHz/0.5V	380	0.69
KTDRH74S-820MCS	82	±20%	100kHz/0.5V	430	0.61
KTDRH74S-101MCS	100	±20%	1kHz/0.5V	610	0.60
KTDRH74S-121MCS	120	±20%	1kHz/0.5V	660	0.52
KTDRH74S-151MCS	150	±20%	1kHz/0.5V	880	0.46
KTDRH74S-181MCS	180	±20%	1kHz/0.5V	980	0.42
KTDRH74S-221MCS	220	±20%	1kHz/0.5V	1170	0.36
KTDRH74S-271MCS	270	±20%	1kHz/0.5V	1640	0.34
KTDRH74S-331MCS	330	±20%	1kHz/0.5V	1860	0.32
KTDRH74S-391MCS	390	±20%	1kHz/0.5V	2850	0.29
KTDRH74S-471MCS	470	±20%	1kHz/0.5V	3010	0.26
KTDRH74S-561MCS	560	±20%	1kHz/0.5V	3620	0.23
KTDRH74S-102MCS	1000	±20%	1kHz/0.5V	6000	0.18

①DCR measured on a micro-ohmmeter.

②Rated current: the DC current at which the inductance decreases by 35% of its nominal value or at which $\Delta t=40^{\circ}\text{C}$, whichever is lower ($T_a=20^{\circ}\text{C}$).

All specifications are subject to change without notice.

Product outline

- Magnetically shielded types.
- A wide range of product line up is available to meet various requirements.
- Excellent saturation current handling to be up to 3.57A.
- For DC/DC converter applications.
- Ideally used in car navigation, LED Lighting, Notebook PC, power modules, etc.
- Custom design is also available.

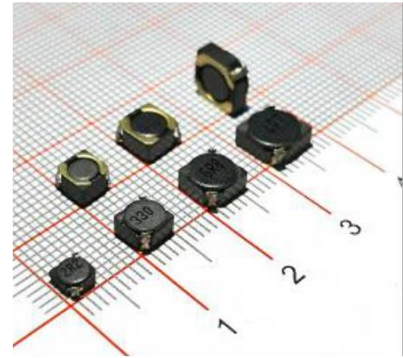

Dimensions(mm)

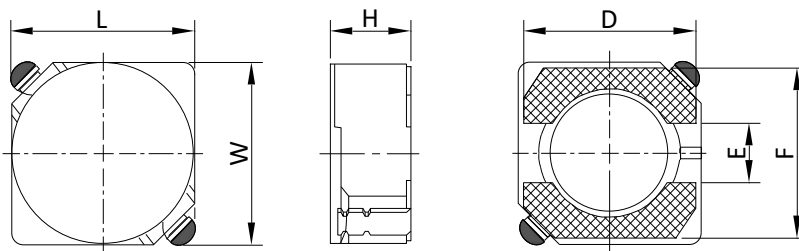

Recommended land patterns

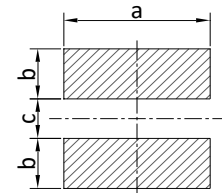

Type	L	W	H	D	E	F	a	b	c	Packaging (pcs/reel)
KT3D16S	3.8±0.2	3.8±0.3	1.6±0.2	3.5	1.0	3.5	4.6	1.6	1.0	3000
KT4D28S	4.70±0.3	4.70±0.3	2.80±0.2	4.5	1.5	4.5	5.3	1.9	1.5	2000
KT5D18S	5.70±0.3	5.70±0.3	1.80±0.2	5.5	2.0	5.5	6.3	2.15	2.0	3000
KT5D28S	5.70±0.3	5.70±0.3	2.80±0.2	5.5	2.0	5.5	6.3	2.15	2.0	2000
KT6D28S	6.70±0.3	6.70±0.3	2.80±0.2	6.5	2.0	6.5	7.3	2.65	2.0	1500
KT6D38S	6.70±0.3	6.70±0.3	3.80±0.2	6.5	2.0	6.5	7.3	2.65	2.0	1000

Dimensions without tolerance are typical.

Product Identification

KT **4D28** **S** - **470** **M** **C** **S**
 ① ② ③ ④ ⑤ ⑥ ⑦

- ① Product Series No.
- ② Dimension symbol: 4D28=4.7x4.7x2.8mm (L x W x H)
- ③ Internal control code.
- ④ Inductance value: 100=10×10⁰ uH=10uH, 2R2=2.2uH, 101=100uH
- ⑤ Tolerance: M=±20%, N=±30%, K=±10%
- ⑥ Packing Style: C=Carrier Tape, B=Bulk
- ⑦ Characteristic parameter level.

All specifications are subject to change without notice.

KT3D16S Electrical Characteristics

Part Number	Inductance (uH) ①	Inductance tolerance	Test Conditions	DCR max. (mΩ) ②	Rated current max.(A) ③
KT3D16S-R26PCS	0.26	±35%	100kHz/0.5V	27	3.60
KT3D16S-R47PCS	0.47	±35%	100kHz/0.5V	35	2.80
KT3D16S-R70PCS	0.7	±35%	100kHz/0.5V	42	2.30
KT3D16S-1R1PCS	1.1	±35%	100kHz/0.5V	50	1.90
KT3D16S-1R5NCS	1.5	±30%	100kHz/0.5V	52	1.58
KT3D16S-2R2NCS	2.2	±30%	100kHz/0.5V	72	1.20
KT3D16S-3R3NCS	3.3	±30%	100kHz/0.5V	85	1.12
KT3D16S-4R7NCS	4.7	±30%	100kHz/0.5V	105	0.92
KT3D16S-6R8NCS	6.8	±30%	100kHz/0.5V	170	0.73
KT3D16S-100MCS	10	±20%	100kHz/0.5V	210	0.56
KT3D16S-150MCS	15	±20%	100kHz/0.5V	290	0.46
KT3D16S-220MCS	22	±20%	100kHz/0.5V	425	0.41
KT3D16S-330MCS	33	±20%	100kHz/0.5V	670	0.33

KT4D28S Electrical Characteristics

Part Number	Inductance (uH) ①	Inductance tolerance	Test Conditions	DCR max. (mΩ) ②	Rated current max. (A) ③
KT4D28S-1R2NCS	1.2	±30%	100kHz/0.5V	23.1	2.61
KT4D28S-1R8NCS	1.8	±30%	100kHz/0.5V	43	2.35
KT4D28S-2R2NCS	2.2	±30%	100kHz/0.5V	45	2.04
KT4D28S-2R7NCS	2.7	±30%	100kHz/0.5V	42.4	1.63
KT4D28S-3R3NCS	3.3	±30%	100kHz/0.5V	65	1.57
KT4D28S-3R9NCS	3.9	±30%	100kHz/0.5V	63.5	1.47
KT4D28S-4R7NCS	4.7	±30%	100kHz/0.5V	72	1.32
KT4D28S-5R6NCS	5.6	±30%	100kHz/0.5V	75	1.30
KT4D28S-6R8NCS	6.8	±30%	100kHz/0.5V	108	1.12
KT4D28S-8R2NCS	8.2	±30%	100kHz/0.5V	117	1.04
KT4D28S-100MCS	10	±20%	100kHz/0.5V	128	1.00
KT4D28S-120MCS	12	±20%	100kHz/0.5V	129	0.86
KT4D28S-150MCS	15	±20%	100kHz/0.5V	180	0.80
KT4D28S-180MCS	18	±20%	100kHz/0.5V	200	0.73
KT4D28S-220MCS	22	±20%	100kHz/0.5V	235	0.70
KT4D28S-270MCS	27	±20%	100kHz/0.5V	256	0.59
KT4D28S-330MCS	33	±20%	100kHz/0.5V	378	0.56
KT4D28S-390MCS	39	±20%	100kHz/0.5V	376	0.51
KT4D28S-470MCS	47	±20%	100kHz/0.5V	587	0.48
KT4D28S-560MCS	56	±20%	100kHz/0.5V	622	0.42
KT4D28S-680MCS	68	±20%	100kHz/0.5V	690	0.38
KT4D28S-820MCS	82	±20%	100kHz/0.5V	792	0.33
KT4D28S-101MCS	100	±20%	100kHz/0.5V	1020	0.29
KT4D28S-121MCS	120	±20%	100kHz/0.5V	1245	0.28
KT4D28S-151MCS	150	±20%	100kHz/0.5V	1350	0.28
KT4D28S-181MCS	180	±20%	100kHz/0.5V	1509	0.22

All specifications are subject to change without notice.

KT5D18S Electrical Characteristics

Part Number	Inductance (uH) ①	Inductance tolerance	Test Conditions	DCR max. (mΩ) ②	Rated current max. (A) ③
KT5D18S-3R3NCS	3.3	±30%	100kHz/0.5V	55	2.2
KT5D18S-4R7NCS	4.7	±30%	100kHz/0.5V	70	1.8
KT5D18S-100MCS	10	±20%	100kHz/0.5V	124	1.2
KT5D18S-120MCS	12	±20%	100kHz/0.5V	150	1.12
KT5D18S-150MCS	15	±20%	100kHz/0.5V	192	0.99
KT5D18S-180MCS	18	±20%	100kHz/0.5V	206	0.87
KT5D18S-220MCS	22	±20%	100kHz/0.5V	290	0.8
KT5D18S-270MCS	27	±20%	100kHz/0.5V	323	0.77
KT5D18S-330MCS	33	±20%	100kHz/0.5V	400	0.6
KT5D18S-390MCS	39	±20%	100kHz/0.5V	510	0.58
KT5D18S-470MCS	47	±20%	100kHz/0.5V	595	0.54
KT5D18S-560MCS	56	±20%	100kHz/0.5V	634	0.48
KT5D18S-680MCS	68	±20%	100kHz/0.5V	670	0.44
KT5D18S-820MCS	82	±20%	100kHz/0.5V	978	0.41
KT5D18S-101MCS	100	±20%	100kHz/0.5V	1112	0.35

KT5D28S Electrical Characteristics

Part Number	Inductance (uH) ①	Inductance tolerance	Test Conditions	DCR max. (mΩ) ②	Rated current max. (A) ③
KT5D28S-2R5NCS	2.5	±30%	100kHz/0.1V	17.6	2.65
KT5D28S-3R0NCS	3.0	±30%	100kHz/0.1V	23.5	2.45
KT5D28S-4R2NCS	4.2	±30%	100kHz/0.1V	30.4	2.24
KT5D28S-4R7NCS	4.7	±30%	100kHz/0.1V	33.0	2.10
KT5D28S-5R3NCS	5.3	±30%	100kHz/0.1V	37.2	1.94
KT5D28S-6R2NCS	6.2	±30%	100kHz/0.1V	45	1.80
KT5D28S-8R2NCS	8.2	±30%	100kHz/0.1V	53	1.60
KT5D28S-100MCS	10	±20%	100kHz/0.1V	67	1.20
KT5D28S-120MCS	12	±20%	100kHz/0.1V	74.5	1.22
KT5D28S-150MCS	15	±20%	100kHz/0.1V	103	1.10
KT5D28S-180MCS	18	±20%	100kHz/0.1V	108	1.02
KT5D28S-220MCS	22	±20%	100kHz/0.1V	150	0.90
KT5D28S-270MCS	27	±20%	100kHz/0.1V	175	0.85
KT5D28S-330MCS	33	±20%	100kHz/0.1V	189	0.75
KT5D28S-390MCS	39	±20%	100kHz/0.1V	208	0.71
KT5D28S-470MCS	47	±20%	100kHz/0.1V	300	0.62
KT5D28S-560MCS	56	±20%	100kHz/0.1V	305	0.58
KT5D28S-680MCS	68	±20%	100kHz/0.1V	355	0.52
KT5D28S-820MCS	82	±20%	100kHz/0.1V	468	0.45
KT5D28S-101MCS	100	±20%	1kHz/0.5V	520	0.42

① Inductance tested using an Agilent/HP 4192A or equivalent.

② DCR measured on a micro-ohmmeter.

③ Rated current: the DC current at which the inductance decreases by 35% of its nominal value or at which $\Delta t=40^{\circ}\text{C}$, whichever is lower ($T_a=20^{\circ}\text{C}$).

KT6D28S Electrical Characteristics

Part Number	Inductance (uH) ①	Inductance tolerance	Test Conditions	DCR max. (mΩ) ②	Rated current max. (A) ③
KT6D28S-2R2NCS	2.2	±30%	100kHz/0.1V	18.0	3.50
KT6D28S-3R9NCS	3.9	±30%	100kHz/0.1V	26.5	2.65
KT6D28S-5R0NCS	5.0	±30%	100kHz/0.1V	30.4	2.45
KT6D28S-6R0NCS	6.0	±30%	100kHz/0.1V	34.3	2.30
KT6D28S-7R3NCS	7.3	±30%	100kHz/0.1V	52.9	2.14
KT6D28S-8R6NCS	8.6	±30%	100kHz/0.1V	56.8	1.89
KT6D28S-100MCS	10	±20%	100kHz/0.1V	63.7	1.73
KT6D28S-120MCS	12	±20%	100kHz/0.1V	68.6	1.58
KT6D28S-150MCS	15	±20%	100kHz/0.1V	82.3	1.43
KT6D28S-180MCS	18	±20%	100kHz/0.1V	93	1.35
KT6D28S-220MCS	22	±20%	100kHz/0.1V	125	1.22
KT6D28S-270MCS	27	±20%	100kHz/0.1V	139	1.07
KT6D28S-330MCS	33	±20%	100kHz/0.1V	162	0.99
KT6D28S-390MCS	39	±20%	100kHz/0.1V	206	0.88
KT6D28S-470MCS	47	±20%	100kHz/0.1V	233	0.82
KT6D28S-560MCS	56	±20%	100kHz/0.1V	271	0.74
KT6D28S-680MCS	68	±20%	100kHz/0.1V	298	0.66
KT6D28S-820MCS	82	±20%	100kHz/0.1V	382	0.61
KT6D28S-101MCS	100	±20%	1kHz/0.5V	524	0.55

KT6D38S Electrical Characteristics

Part Number	Inductance (uH) ①	Inductance tolerance	Test Conditions	DCR max. (mΩ) ②	Rated current max. (A) ③
KT6D38S-3R3NCS	3.3	±30%	100kHz/0.1V	20	3.72
KT6D38S-100MCS	10	±20%	100kHz/0.1V	48	2.00
KT6D38S-120MCS	12	±20%	100kHz/0.1V	53	1.70
KT6D38S-150MCS	15	±20%	100kHz/0.1V	57	1.60
KT6D38S-180MCS	18	±20%	100kHz/0.1V	92	1.50
KT6D38S-220MCS	22	±20%	100kHz/0.1V	96	1.30
KT6D38S-270MCS	27	±20%	100kHz/0.1V	109	1.20
KT6D38S-330MCS	33	±20%	100kHz/0.1V	124	1.10
KT6D38S-390MCS	39	±20%	100kHz/0.1V	138	1.00
KT6D38S-470MCS	47	±20%	100kHz/0.1V	155	0.95
KT6D38S-560MCS	56	±20%	100kHz/0.1V	202	0.85
KT6D38S-680MCS	68	±20%	100kHz/0.1V	234	0.75
KT6D38S-820MCS	82	±20%	100kHz/0.1V	324	0.70
KT6D38S-101MCS	100	±20%	1kHz/0.5V	358	0.65

① Inductance tested using an Agilent/HP 4192A or equivalent.

② DCR measured on a micro-ohmmeter.

③ Rated current: the DC current at which the inductance decreases by 35% of its nominal value or at which $\Delta t=40^{\circ}\text{C}$, whichever is lower ($T_a=20^{\circ}\text{C}$).

Product Outline

- Inductance is up to 8.0mH
- A wide range of product line up is available to meet the various requirements.
- For DC/DC converter applications and power chokes.
- Ideally used in PDA, HDD,DSC/DVC,portable DVD, car navigation, LED lighting,smart screen, power module,etc.
- Custom design is also available.

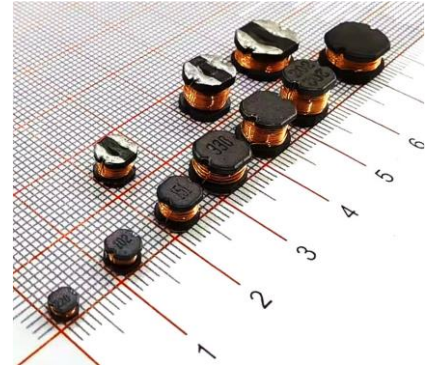

Dimensions(mm)

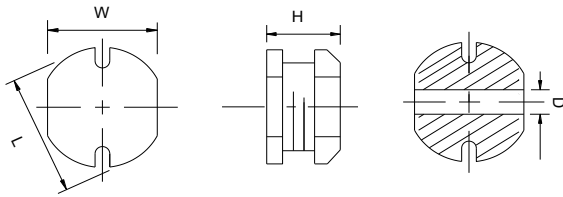

Recommended Patterns

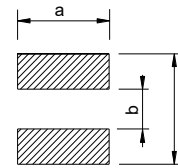

Type	L	W	H	D	a	b	c	Packaging (pcs/reel)
CD3521S	3.5±0.3	3.0±0.3	2.4 max.	1.0	3.5	0.8	4.0	3000
CD4532S	4.5±0.3	4.0±0.3	3.5 max.	1.6	4.5	1.5	5.0	2000
CD5830S	5.8±0.3	5.2±0.3	3.3 max.	2.0	5.5	1.7	6.0	2000
CD5845S	5.8±0.3	5.2±0.3	4.8 max.	2.0	5.5	1.7	6.0	1500
CD5845H	5.8±0.3	5.2±0.3	4.8 max.	2.0	5.5	1.7	6.0	1500
CD7850S	7.8±0.3	7.0±0.3	5.3 max.	2.5	7.5	2.0	8.0	1000
CD7850H	7.8±0.3	7.0±0.3	5.3 max.	2.5	7.5	2.0	8.0	1000
CD7862H	7.8±0.3	7.0±0.3	6.5 max.	2.6	7.5	2.0	8.0	900
CD7870H	7.8±0.3	7.0±0.3	7.3 max.	2.6	7.5	2.0	8.0	800
CD1054S/H	10.0±0.3	9.0±0.3	5.7 max.	3.0	9.5	2.5	10.0	750

Dimensions without tolerance are typical.

Product Identification

CD **7850** **S** - **470** **K** **C** **S**
 ① ② ③ ④ ⑤ ⑥ ⑦

- ① Product Series No.
- ② Dimension symbol. 7850=7.8 x 5.0mm (L x H)
- ③ Internal control code.
- ④ Inductance value. 470=47×10⁰ uH=47 uH 2R2=2.2uH,101=100uH,182=1800uH
- ⑤ Tolerance. M=±20%, K=±10%,N=±30%
- ⑥ Packing Style, C=Carrier Tape, B=Bulk
- ⑦ Characteristic parameter level.

All specifications are subject to change without notice.

CD3521S Electrical Characteristics

Part Number	Inductance (uH) ①	Inductance tolerance	Test Conditions	DCR max. (mΩ) ②	Rated current (A) ③
CD3521S-1R0MCS	1.0	±20%	100kHz/0.5V	50	1.85
CD3521S-1R5MCS	1.5	±20%	100kHz/0.5V	60	1.80
CD3521S-2R2MCS	2.2	±20%	100kHz/0.5V	80	1.60
CD3521S-3R3MCS	3.3	±20%	100kHz/0.5V	100	1.40
CD3521S-3R9MCS	3.9	±20%	100kHz/0.5V	150	1.30
CD3521S-4R7MCS	4.7	±20%	100kHz/0.5V	165	1.25
CD3521S-5R6MCS	5.6	±20%	100kHz/0.5V	185	1.20
CD3521S-6R8MCS	6.8	±20%	100kHz/0.5V	210	1.10
CD3521S-8R2MCS	8.2	±20%	100kHz/0.5V	240	1.05
CD3521S-100KCS	10	±10%	100kHz/0.5V	350	0.76
CD3521S-150KCS	15	±10%	100kHz/0.5V	500	0.64
CD3521S-220KCS	22	±10%	100kHz/0.5V	650	0.50
CD3521S-330KCS	33	±10%	100kHz/0.5V	850	0.38
CD3521S-390KCS	39	±10%	100kHz/0.5V	1000	0.36
CD3521S-470KCS	47	±10%	100kHz/0.5V	1600	0.33
CD3521S-560KCS	56	±10%	100kHz/0.5V	1650	0.29
CD3521S-680KCS	68	±10%	100kHz/0.5V	1850	0.28
CD3521S-820KCS	82	±10%	100kHz/0.5V	2100	0.25
CD3521S-101KCS	100	±10%	1kHz/0.5V	3200	0.22
CD3521S-181KCS	180	±10%	1kHz/0.5V	5000	0.20

CD4532S Electrical Characteristics

Part Number	Inductance (uH) ①	Inductance tolerance	Test Conditions	DCR max. (mΩ) ②	Rated current (A) ③
CD4532S-1R0MCS	1.0	±20%	100kHz/0.5V	45	3.50
CD4532S-2R2MCS	2.2	±20%	100kHz/0.5V	70	2.40
CD4532S-2R7MCS	2.7	±20%	100kHz/0.5V	75	2.30
CD4532S-3R3MCS	3.3	±20%	100kHz/0.5V	85	2.25
CD4532S-3R9MCS	3.9	±20%	100kHz/0.5V	90	1.70
CD4532S-4R7MCS	4.7	±20%	100kHz/0.5V	105	1.65
CD4532S-5R6MCS	5.6	±20%	100kHz/0.5V	120	1.60
CD4532S-6R8MCS	6.8	±20%	100kHz/0.5V	130	1.40
CD4532S-8R2MCS	8.2	±20%	100kHz/0.5V	145	1.30
CD4532S-100KCS	10	±10%	100kHz/0.5V	180	1.10
CD4532S-120KCS	12	±10%	100kHz/0.5V	210	1.00
CD4532S-150KCS	15	±10%	100kHz/0.5V	235	0.85
CD4532S-180KCS	18	±10%	100kHz/0.5V	330	0.80
CD4532S-220KCS	22	±10%	100kHz/0.5V	360	0.70
CD4532S-270KCS	27	±10%	100kHz/0.5V	520	0.65
CD4532S-330KCS	33	±10%	100kHz/0.5V	540	0.60
CD4532S-390KCS	39	±10%	100kHz/0.5V	580	0.55
CD4532S-470KCS	47	±10%	100kHz/0.5V	840	0.48
CD4532S-560KCS	56	±10%	100kHz/0.5V	930	0.46
CD4532S-680KCS	68	±10%	100kHz/0.5V	1110	0.44
CD4532S-820KCS	82	±20%	100kHz/0.5V	1250	0.42
CD4532S-101KCS	100	±10%	1kHz/0.5V	1400	0.40
CD4532S-121KCS	120	±10%	1kHz/0.5V	1500	0.38

All specifications are subject to change without notice.

CD4532S Electrical Characteristics

Part Number	Inductance (uH) ①	Inductance tolerance	Test Conditions	DCR max. (mΩ) ②	Rated current (A) ③
CD4532S-151KCS	150	±10%	1kHz/0.5V	2000	0.35
CD4532S-181KCS	180	±10%	1kHz/0.5V	2120	0.30
CD4532S-221KCS	220	±10%	1kHz/0.5V	2460	0.27
CD4532S-271KCS	270	±10%	1kHz/0.5V	2980	0.23
CD4532S-331KCS	330	±10%	1kHz/0.5V	4500	0.20
CD4532S-471KCS	470	±10%	1kHz/0.5V	5500	0.16
CD4532S-561KCS	560	±10%	1kHz/0.5V	6000	0.14
CD4532S-681KCS	680	±10%	1kHz/0.5V	6800	0.13

CD5845S Electrical Characteristics

Part Number	Inductance (uH) ①	Inductance tolerance	Test Conditions	DCR max. (mΩ) ②	Rated current (A) ③
CD5845S-1R0MCS	1.0	±20%	100kHz/0.5V	25	3.50
CD5845S-1R5MCS	1.5	±20%	100kHz/0.5V	25	3.30
CD5845S-2R2MCS	2.2	±20%	100kHz/0.5V	28	3.20
CD5845S-2R7MCS	2.7	±20%	100kHz/0.5V	30	3.00
CD5845S-3R3MCS	3.3	±20%	100kHz/0.5V	35	2.50
CD5845S-3R9MCS	3.9	±20%	100kHz/0.5V	38	2.40
CD5845S-4R7MCS	4.7	±20%	100kHz/0.5V	40	2.30
CD5845S-5R0MCS	5.0	±20%	100kHz/0.5V	49	2.20
CD5845S-5R6MCS	5.6	±20%	100kHz/0.5V	50	2.10
CD5845S-6R8MCS	6.8	±20%	100kHz/0.5V	55	2.00
CD5845S-7R2MCS	7.2	±20%	100kHz/0.5V	70	1.80
CD5845S-8R2MCS	8.2	±20%	100kHz/0.5V	90	1.70
CD5845S-100KCS	10	±10%	100kHz/0.5V	100	1.65
CD5845S-120KCS	12	±10%	100kHz/0.5V	120	1.55
CD5845S-150KCS	15	±10%	100kHz/0.5V	140	1.40
CD5845S-180KCS	18	±10%	100kHz/0.5V	150	1.25
CD5845S-200KCS	20	±10%	100kHz/0.5V	160	1.15
CD5845S-220KCS	22	±10%	100kHz/0.5V	180	1.10
CD5845S-270KCS	27	±10%	100kHz/0.5V	200	0.95
CD5845S-330KCS	33	±10%	100kHz/0.5V	220	0.90
CD5845S-390KCS	39	±10%	100kHz/0.5V	300	0.80
CD5845S-470KCS	47	±10%	100kHz/0.5V	350	0.75
CD5845S-560KCS	56	±10%	100kHz/0.5V	400	0.70
CD5845S-680KCS	68	±10%	100kHz/0.5V	450	0.65
CD5845S-820KCS	82	±10%	100kHz/0.5V	600	0.60
CD5845S-101KCS	100	±10%	1kHz/0.5V	700	0.55
CD5845S-121KCS	120	±10%	1kHz/0.5V	850	0.45
CD5845S-151KCS	150	±10%	1kHz/0.5V	1100	0.43
CD5845S-181KCS	180	±10%	1kHz/0.5V	1350	0.40
CD5845S-221KCS	220	±10%	1kHz/0.5V	1550	0.35
CD5845S-301KCS	300	±10%	1kHz/0.5V	1690	0.32
CD5845S-331KCS	330	±10%	1kHz/0.5V	1760	0.30
CD5845S-391KCS	390	±10%	1kHz/0.5V	1890	0.27
CD5845S-471KCS	470	±10%	1kHz/0.5V	2500	0.25

All specifications are subject to change without notice.

CD5845S Electrical Characteristics

Part Number	Inductance (uH) ①	Inductance tolerance	Test Conditions	DCR max. (mΩ) ②	Rated current (A) ③
CD5845S-511KCS	510	±10%	1kHz/0.5V	2700	0.22
CD5845S-561KCS	560	±10%	1kHz/0.5V	2870	0.20
CD5845S-681KCS	680	±10%	1kHz/0.5V	3500	0.18
CD5845S-821KCS	820	±10%	1kHz/0.5V	5200	0.17

CD5845H Electrical Characteristics

Part Number	Inductance (uH) ①	Inductance tolerance	Test Conditions	DCR max. (Ω) ②	Rated current (A) ③
CD5845H-501KCS	500	±10%	1kHz/0.5V	4.0	0.45
CD5845H-102KCS	1000	±10%	1kHz/0.5V	7.0	0.25
CD5845H-152KCS	1500	±10%	1kHz/0.5V	11.5	0.22
CD5845H-182KCS	1800	±10%	1kHz/0.5V	11.7	0.19
CD5845H-202KCS	2000	±10%	1kHz/0.5V	13.0	0.18
CD5845H-222KCS	2200	±10%	1kHz/0.5V	13.8	0.17
CD5845H-252KCS	2500	±10%	1kHz/0.5V	14.0	0.16
CD5845H-302KCS	3000	±10%	1kHz/0.5V	20.0	0.15
CD5845H-402KCS	4000	±10%	1kHz/0.5V	23.0	0.12
CD5845H-502KCS	5000	±10%	1kHz/0.5V	35.0	0.12

CD7850S Electrical Characteristics

Part Number	Inductance (uH) ①	Inductance tolerance	Test Conditions	DCR max. (mΩ) ②	Rated current (A) ③
CD7850S-1R0MCS	1.0	±20%	100kHz/0.5V	15	5.80
CD7850S-1R5MCS	1.5	±20%	100kHz/0.5V	17	5.50
CD7850S-2R2MCS	2.2	±20%	100kHz/0.5V	18	5.20
CD7850S-2R7MCS	2.7	±20%	100kHz/0.5V	23	5.00
CD7850S-3R3MCS	3.3	±20%	100kHz/0.5V	25	4.80
CD7850S-3R9MCS	3.9	±20%	100kHz/0.5V	27	4.20
CD7850S-4R7MCS	4.7	±20%	100kHz/0.5V	28	4.00
CD7850S-5R6MCS	5.6	±20%	100kHz/0.5V	30	3.80
CD7850S-6R0MCS	6.0	±20%	100kHz/0.5V	32	3.20
CD7850S-6R8MCS	6.8	±20%	100kHz/0.5V	36	3.00
CD7850S-8R2MCS	8.2	±20%	100kHz/0.5V	42	2.70
CD7850S-100KCS	10	±10%	100kHz/0.5V	70	2.55
CD7850S-120KCS	12	±10%	100kHz/0.5V	80	2.40
CD7850S-150KCS	15	±10%	100kHz/0.5V	90	2.00
CD7850S-180KCS	18	±10%	100kHz/0.5V	100	1.95
CD7850S-220KCS	22	±10%	100kHz/0.5V	110	1.70
CD7850S-270KCS	27	±10%	100kHz/0.5V	120	1.55
CD7850S-330KCS	33	±10%	100kHz/0.5V	130	1.40
CD7850S-390KCS	39	±10%	100kHz/0.5V	150	1.35
CD7850S-470KCS	47	±10%	100kHz/0.5V	190	1.25
CD7850S-560KCS	56	±10%	100kHz/0.5V	230	1.10
CD7850S-680KCS	68	±10%	100kHz/0.5V	250	1.00
CD7850S-820KCS	82	±10%	100kHz/0.5V	300	0.95

All specifications are subject to change without notice.

CD7850S Electrical Characteristics

Part Number	Inductance (uH) ①	Inductance tolerance	Test Conditions	DCR max. (mΩ) ②	Rated current (A) ③
CD7850S-850KCS	85	±10%	100kHz/0.5V	320	0.90
CD7850S-101KCS	100	±10%	1kHz/0.5V	400	0.78
CD7850S-121KCS	120	±10%	1kHz/0.5V	450	0.73
CD7850S-151KCS	150	±10%	1kHz/0.5V	600	0.70
CD7850S-181KCS	180	±10%	1kHz/0.5V	700	0.60
CD7850S-201KCS	200	±10%	1kHz/0.5V	900	0.58
CD7850S-221KCS	220	±10%	1kHz/0.5V	950	0.55
CD7850S-271KCS	270	±10%	1kHz/0.5V	1100	0.50
CD7850S-331KCS	330	±10%	1kHz/0.5V	1250	0.45
CD7850S-391KCS	390	±10%	1kHz/0.5V	1750	0.40
CD7850S-471KCS	470	±10%	1kHz/0.5V	1950	0.35
CD7850S-561KCS	560	±10%	1kHz/0.5V	1980	0.32
CD7850S-681KCS	680	±10%	1kHz/0.5V	2180	0.31
CD7850S-821KCS	820	±10%	1kHz/0.5V	2300	0.30

CD7850H Electrical Characteristics

Part Number	Inductance (uH) ①	Inductance tolerance	Test Conditions	DCR max. (Ω) ②	Rated current (A) ③
CD7850H-501KCS	500	±10%	1kHz/0.5V	2.1	0.63
CD7850H-102KCS	1000	±10%	1kHz/0.5V	5.3	0.39
CD7850H-152KCS	1500	±10%	1kHz/0.5V	7.5	0.36
CD7850H-182KCS	1800	±10%	1kHz/0.5V	7.8	0.32
CD7850H-202KCS	2000	±10%	1kHz/0.5V	9.0	0.30
CD7850H-222KCS	2200	±10%	1kHz/0.5V	9.8	0.28
CD7850H-252KCS	2500	±10%	1kHz/0.5V	11.5	0.27
CD7850H-302KCS	3000	±10%	1kHz/0.5V	12.2	0.27
CD7850H-332KCS	3300	±10%	1kHz/0.5V	14.5	0.24
CD7850H-472KCS	4700	±10%	1kHz/0.5V	18.5	0.19
CD7850H-502KCS	5000	±10%	1kHz/0.5V	22.0	0.18
CD7850H-602KCS	6000	±10%	1kHz/0.5V	25.0	0.17
CD7850H-682KCS	6800	±10%	1kHz/0.5V	28.0	0.16
CD7850H-802KCS	8000	±10%	1kHz/0.5V	36.0	0.15

CD7862H Electrical Characteristics

Part Number	Inductance (uH) ①	Inductance tolerance	Test Conditions	DCR max. (Ω) ②	Rated current (A) ③
CD7862H-701KCS	700	±10%	1kHz/0.5V	3.0	0.68
CD7862H-102KCS	1000	±10%	1kHz/0.5V	3.5	0.56
CD7862H-152KCS	1500	±10%	1kHz/0.5V	6.0	0.45
CD7862H-182KCS	1800	±10%	1kHz/0.5V	6.2	0.42
CD7862H-202KCS	2000	±10%	1kHz/0.5V	6.7	0.40
CD7862H-302KCS	3000	±10%	1kHz/0.5V	11.5	0.30

All specifications are subject to change without notice.

CD7870H Electrical Characteristics

Part Number	Inductance (uH) ①	Inductance tolerance	Test Conditions	DCR max. (Ω) ②	Rated current (A) ③
CD7870H-701KCS	700	±10%	1kHz/0.5V	3.0	0.70
CD7870H-801KCS	800	±10%	1kHz/0.5V	3.1	0.65
CD7870H-821KCS	820	±10%	1kHz/0.5V	3.2	0.64
CD7870H-102KCS	1000	±10%	1kHz/0.5V	4.5	0.58
CD7870H-122KCS	1200	±10%	1kHz/0.5V	5.1	0.55
CD7870H-152KCS	1500	±10%	1kHz/0.5V	6.2	0.47
CD7870H-182KCS	1800	±10%	1kHz/0.5V	6.3	0.45
CD7870H-202KCS	2000	±10%	1kHz/0.5V	7.4	0.43
CD7870H-222KCS	2200	±10%	1kHz/0.5V	7.8	0.40
CD7870H-252KCS	2500	±10%	1kHz/0.5V	8.25	0.38
CD7870H-302KCS	3000	±10%	1kHz/0.5V	12.0	0.37
CD7870H-332KCS	3300	±10%	1kHz/0.5V	12.5	0.34
CD7870H-402KCS	4000	±10%	1kHz/0.5V	15.0	0.30
CD7870H-442KCS	4400	±10%	1kHz/0.5V	15.4	0.29
CD7870H-472KCS	4700	±10%	1kHz/0.5V	16.0	0.28
CD7870H-482KCS	4800	±10%	1kHz/0.5V	16.5	0.28
CD7870H-522KCS	5200	±10%	1kHz/0.5V	20.5	0.27

CD1054S/H Electrical Characteristics

Part Number	Inductance (uH) ①	Inductance tolerance	Test Conditions	DCR max. (mΩ) ②	Rated current (A) ③
CD1054S-1R0MCS	1.0	±20%	100kHz/0.5V	10	8.00
CD1054S-2R2MCS	2.2	±20%	100kHz/0.5V	15	7.20
CD1054S-3R3MCS	3.3	±20%	100kHz/0.5V	18	7.00
CD1054S-4R7MCS	4.7	±20%	100kHz/0.5V	20	6.00
CD1054S-6R2MCS	6.2	±20%	100kHz/0.5V	22	5.00
CD1054S-8R2MCS	8.2	±20%	100kHz/0.5V	50	4.00
CD1054S-100KCS	10	±10%	100kHz/0.5V	60	3.80
CD1054S-120KCS	12	±10%	100kHz/0.5V	70	3.40
CD1054S-150KCS	15	±10%	100kHz/0.5V	80	2.90
CD1054S-180KCS	18	±10%	100kHz/0.5V	90	2.65
CD1054S-220KCS	22	±10%	100kHz/0.5V	100	2.50
CD1054S-270KCS	27	±10%	100kHz/0.5V	110	2.25
CD1054S-330KCS	33	±10%	100kHz/0.5V	120	2.00
CD1054S-390KCS	39	±10%	100kHz/0.5V	130	1.90
CD1054S-470KCS	47	±10%	100kHz/0.5V	150	1.70
CD1054S-560KCS	56	±10%	100kHz/0.5V	190	1.60
CD1054S-680KCS	68	±10%	100kHz/0.5V	220	1.45
CD51054S-820KCS	82	±10%	100kHz/0.5V	250	1.30
CD1054S-101KCS	100	±10%	1kHz/0.5V	330	1.15
CD1054S-121KCS	120	±10%	1kHz/0.5V	400	1.00
CD1054S-151KCS	150	±10%	1kHz/0.5V	450	0.95
CD1054S-181KCS	180	±10%	1kHz/0.5V	600	0.85
CD1054S-221KCS	220	±10%	1kHz/0.5V	700	0.75
CD1054S-271KCS	270	±10%	1kHz/0.5V	950	0.70

All specifications are subject to change without notice.

CD1054S/H Electrical Characteristics

Part Number	Inductance (uH) ①	Inductance tolerance	Test Conditions	DCR max. (mΩ) ②	Rated current (A) ③
CD1054S-331KCS	330	±10%	1kHz/0.5V	1100	0.60
CD1054S-391KCS	390	±10%	1kHz/0.5V	1200	0.55
CD1045S-471KCS	470	±10%	1kHz/0.5V	1450	0.50
CD1054S-561KCS	560	±10%	1kHz/0.5V	1900	0.48
CD1054S-621KCS	620	±10%	1kHz/0.5V	2000	0.46
CD1054S-681KCS	680	±10%	1kHz/0.5V	2250	0.45
CD1054S-821KCS	820	±10%	1kHz/0.5V	2500	0.40
CD1054H-102KCS	1000	±10%	1kHz/0.5V	3000	0.45④
CD1054H-502KCS	5000	±10%	1kHz/0.5V	11500	0.22④
CD1054H-562KCS	5600	±10%	1kHz/0.5V	14500	0.20④

Notes:

- ① Inductance tested using an Agilent/HP 4192A or equivalent.
- ② DCR measured on a micro-ohmmeter.
- ③ Rated current: The DC current at which the inductance decreases by 10% of its nominal value or at which $\Delta t=40^{\circ}\text{C}$, whichever is lower($T_a=20^{\circ}\text{C}$).

Product Outline

- Handles current up to 2.9A.
- Ceramic base with Au plating is used for high temperature applications.
- For DC/DC converter applications.
- Custom design is also available.



Dimensions(mm)

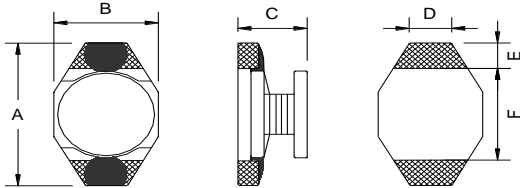

Recommended Patterns

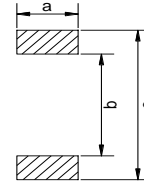

Type	A	B	C	D	E	F	a	b	c	Packaging (pcs/reel)
CBF1608C	6.6±0.2	4.45±0.2	2.92 max.	1.3	1.3	4.0	3.6	4.0	6.9	2500

Dimensions without tolerance are typical

CBF1608C Electrical Characteristics

Part Number	Inductance ① (uH)	Inductance tolerance	DCR ② (mΩ) max.	Isat ③ (A) max.	Irms ③ (A) typ.	SRF Ref. (MHz)
CBF1608C-1R0MCS	1.0	±20%	50	2.9	2.9	130
CBF1608C-1R5MCS	1.5	±20%	60	2.6	2.8	115
CBF1608C-2R2MCS	2.2	±20%	70	2.3	2.4	100
CBF1608C-2R7MCS	2.7	±20%	80	2.1	2.1	75
CBF1608C-3R3MCS	3.3	±20%	80	2.0	2.0	70
CBF1608C-4R7MCS	4.7	±20%	90	1.5	1.5	50
CBF1608C-6R8MCS	6.8	±20%	130	1.2	1.4	45
CBF1608C-8R2MCS	8.2	±20%	160	1.15	1.3	40
CBF1608C-100MCS	10	±20%	160	1.10	1.2	35
CBF1608C-150MCS	15	±20%	230	0.90	1.1	30
CBF1608C-220MCS	22	±20%	370	0.70	0.8	20
CBF1608C-330MCS	33	±20%	510	0.58	0.6	15
CBF1608C-470MCS	47	±20%	640	0.50	0.5	14
CBF1608C-680MCS	68	±20%	860	0.40	0.4	11
CBF1608C-101MCS	100	±20%	1270	0.31	0.3	9
CBF1608C-151MCS	150	±20%	2000	0.27	0.25	6
CBF1608C-221MCS	220	±20%	3110	0.22	0.20	5.5
CBF1608C-331MCS	330	±20%	3800	0.18	0.16	5
CBF1608C-471MCS	470	±20%	5060	0.16	0.15	4
CBF1608C-681MCS	680	±20%	9200	0.14	0.12	3
CBF1608C-102MCS	1000	±20%	13800	0.10	0.07	2

① Inductance tested at 100kHz/ 0.1 Vrms using an Agilent/HP 4192A or equivalent.

② DCR measured on a micro-ohmmeter.

③ Rated current: The DC current at which the inductance decreases by 10% of its nominal value or at which $\Delta t=40^{\circ}\text{C}$, whichever is lower ($T_a=20^{\circ}\text{C}$).

All specifications are subject to change without notice.

Product Outline

- Excellent saturation current handling to be up to 8.6A.
- Low DC resistance keeps power losses to a minimum.
- For DC-DC converter applications.
- Ideally used in thin-screen TV, LCDs, AV equipment and other electronic devices.
- Custom design is also available.



Dimensions(mm)

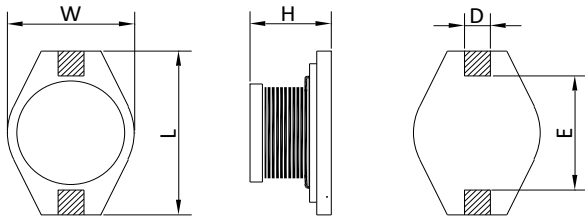

Recommended Patterns

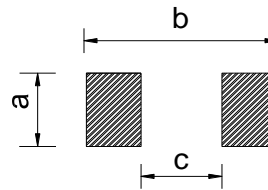

Schematics

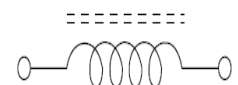

Type	L	W	H	D	E	a	b	c	Packaging (pcs/reel)
SBF3316M	12.95±0.2	9.3±0.2	5.20 max.	2.54	7.62	2.8	13.2	7.4	1000
SBF3340M	12.95±0.2	9.4±0.2	11.43max.	2.54	7.62	2.8	13.2	7.4	350
SBF5022M	18.2±0.2	14.0±0.2	7.10 max.	2.54	12.65	2.8	18.4	12.4	300

Dimensions without tolerance are typical

SBF3316M Electrical Characteristics

Part Number	Inductance (uH) ①	Inductance tolerance	DCR max. (mΩ) ②	Rated current (A) ③
SBF3316M-1R0MT01	1.0	±20%	9.0	6.8
SBF3316M-1R5MT01	1.5	±20%	10	6.4
SBF3316M-2R2MT01	2.2	±20%	11.9	6.1
SBF3316M-3R3MT01	3.3	±20%	15	5.4
SBF3316M-4R7MT01	4.7	±20%	17.8	4.8
SBF3316M-6R8MT01	6.8	±20%	26.8	4.4
SBF3316M-100MT01	10	±20%	37.5	3.88
SBF3316M-150MT01	15	±20%	45.8	3.06
SBF3316M-220MT01	22	±20%	84.7	2.35
SBF3316M-330MT01	33	±20%	99.5	2.04
SBF3316M-470MT01	47	±20%	140	1.63
SBF3316M-680MT01	68	±20%	195	1.43
SBF3316M-101MT01	100	±20%	274	1.22
SBF3316M-151MT01	150	±20%	398	1.0
SBF3316M-221MT01	220	±20%	608	0.8
SBF3316M-331MT01	330	±20%	1015	0.6
SBF3316M-471MT01	470	±20%	1265	0.5
SBF3316M-681MT01	680	±20%	2015	0.4
SBF3316M-102MT01	1000	±20%	2995	0.3
SBF3316M-152MT01	1500	±20%	4490	0.27
SBF3316M-332MT01	3300	±20%	8968	0.17

All specifications are subject to change without notice.

SBF3340M Electrical Characteristics

Part Number	Inductance (uH) ①	Inductance tolerance	DCR max. (mΩ) ②	Rated current (A) ③
SBF3340M-100MT01	10	±20%	40	3.57
SBF3340M -150MT01	15	±20%	50	3.06
SBF3340M -220MT01	22	±20%	66	2.55
SBF3340M -330MT01	33	±20%	79.8	2.04
SBF3340M -470MT01	47	±20%	109	1.63
SBF3340M -680MT01	68	±20%	168	1.22
SBF3340M -101MT01	100	±20%	220	1.22
SBF3340M -151MT01	150	±20%	340	0.92
SBF3340M -221MT01	220	±20%	438	0.71
SBF3340M -331MT01	330	±20%	698	0.61
SBF3340M -471MT01	470	±20%	948	0.31
SBF3340M -681MT01	680	±20%	1150	0.20
SBF3340M -102MT01	1000	±20%	1995	0.10

SBF5022M Electrical Characteristics

Part Number	Inductance (uH) ①	Inductance tolerance	DCR max. (mΩ) ②	Rated current (A) ③
SBF5022M-1R0MT01	1.0	±20%	9	8.6
SBF5022M-2R2MT01	2.2	±20%	14	7.1
SBF5022M-3R3MT01	3.3	±20%	16	6.2
SBF5022M-5R6MT01	5.6	±20%	20	5.3
SBF5022M-8R2MT01	8.2	±20%	29	4.8
SBF5022M-100MT01	10	±20%	31	4.3
SBF5022M-150MT01	15	±20%	36	4.0
SBF5022M-220MT01	22	±20%	47	3.5
SBF5022M-330MT01	33	±20%	66	3.0
SBF5022M-470MT01	47	±20%	86	2.6
SBF5022M-680MT01	68	±20%	130	2.3
SBF5022M-101MT01	100	±20%	190	1.8
SBF5022M-151MT01	150	±20%	250	1.5
SBF5022M-221MT01	220	±20%	380	1.2
SBF5022M-331MT01	330	±20%	560	1.0
SBF5022M-471MT01	470	±20%	850	0.82
SBF5022M-681MT01	680	±20%	1100	0.72
SBF5022M-102MT01	1000	±20%	1800	0.56

① Inductance tested at 100kHz/0.1 Vrms using an Agilent/HP 4192A or equivalent.

② DCR measured on a micro-ohmmeter.

③ Rated current: The DC current at which the inductance decreases by 10% of its nominal value or at which $\Delta t=40^{\circ}\text{C}$, whichever is lower ($T_a=20^{\circ}\text{C}$).

DEP Series Ultra High Current Power Inductors

Product Outline

- Mn-Zn core is used to realize excellent saturation characteristic.
- Flat wire is used to realize ultra low DCR and higher temperature rise rated current.
- For high current DC/DC converter applications.
- Ideally used in LCD, Notebook PC CPU power supply, server etc.
- Custom design is also available.



Dimensions(mm)



Recommended Patterns

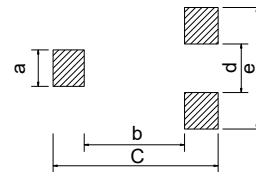

Type	L	W	H	D	E	F	G	a	b	c	d	e	Packaging (pcs/reel)
DEP1256H	12.5±0.2	12.5±0.2	5.6 max.	8.2	7.0	2.6	2.1	3.0	8.2	13.5	4.0	10.0	500
DEP1349S	13.5±0.2	13.5±0.2	4.9 max.	9.6	7.2	2.6	2.5	2.7	9.4	15.0	4.4	10.0	500

Dimensions without tolerance are typical.

DEP1256H Electrical Characteristics

Part Number	Inductance (uH) ①	Inductance Tolerance	DCR ② (mΩ) max.	Isat ③ (A) max.	Irms ③ (A) typ.
DEP1256H-R90NT01	0.9	±30%	2.2	20.5	18.2
DEP1256H-1R0NT01	1.0	±30%	2.2	20.3	18.2
DEP1256H-1R8NT01	1.8	±30%	3.4	15.5	15.5
DEP1256H-2R8MT01	2.8	±20%	5.5	12.5	12.5
DEP1256H-4R0MT01	4.0	±20%	8.0	10.5	10.0
DEP1256H-5R6MT01	5.6	±20%	11.3	9.0	8.4
DEP1256H-7R2MT01	7.2	±20%	13.5	7.9	7.7
DEP1256H-100MT01	10	±20%	13.5	5.0	7.6

DEP1349S Electrical Characteristics

Part Number	Inductance (uH) ①	Inductance Tolerance	DCR ② (mΩ) max.	Isat ③ (A) max.	Irms ③ (A) typ.
DEP1349S-R90NT01	0.9	±30%	2.45	22.03	17.34
DEP1349S-2R5NT01	2.5	±30%	6.47	13.06	10.71
DEP1349S-3R6MT01	3.6	±20%	10.58	11.12	8.16
DEP1349S-4R8MT01	4.8	±20%	11.76	9.49	7.65
DEP1349S-6R4MT01	6.4	±20%	15.97	8.16	7.14
DEP1349S-8R0MT01	8.0	±20%	18.03	7.34	6.63

① Inductance tested at 100kHz, 0.1 Vrms using an Agilent/HP 4192A or equivalent.

② DCR measured on a micro-ohmmeter.

③ Rated current: The DC current at which the inductance decreases by 25% of its nominal value or at which $\Delta t=40^{\circ}\text{C}$, whichever is lower ($T_a=20^{\circ}\text{C}$).

All specifications are subject to change without notice.

Dimensions(mm)

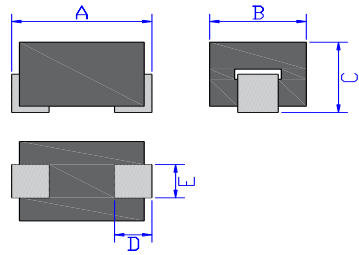

Schematics

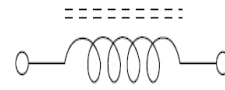

Part Number	A	B	C	D	E	Packaging pcs/reel
HCBD323023-390T01	3.1±0.3	2.9±0.25	2.2±0.25	0.8±0.2.	0.85±0.2	1000
HCBD403025-530T01	4.7±0.5	3.0±0.25	2.8±0.25	1.4±0.2.	1.4±0.2	500
HCBD853225-101T01	9.0±0.5	3.1±0.25	2.8±0.25	1.5±0.5	1.2±0.2	500

Dimensions do not include solder on the Pins

Electrical Characteristics

Part Number	Impedance(Ω) at 25MHz	Impedance(Ω) at 100MHz	DCR(mΩ) Max.	Rated Current ΔT=40°C
HCBD323023-390T01	23 Typ.	39±30%	0.6	15A Typ.
HCBD403025-530T01	33 Typ.	53±25%	0.6	15A Typ.
HCBD853225-101T01	64 Typ.	100±25%	1.2	15A Typ.

- ① Rated current based on Temp. rise 40°Cmax.
- ② Operating Temperature: -40 to 125°C
- ③ Storage Temperature: -40 to 125°C

Impedance Z-f

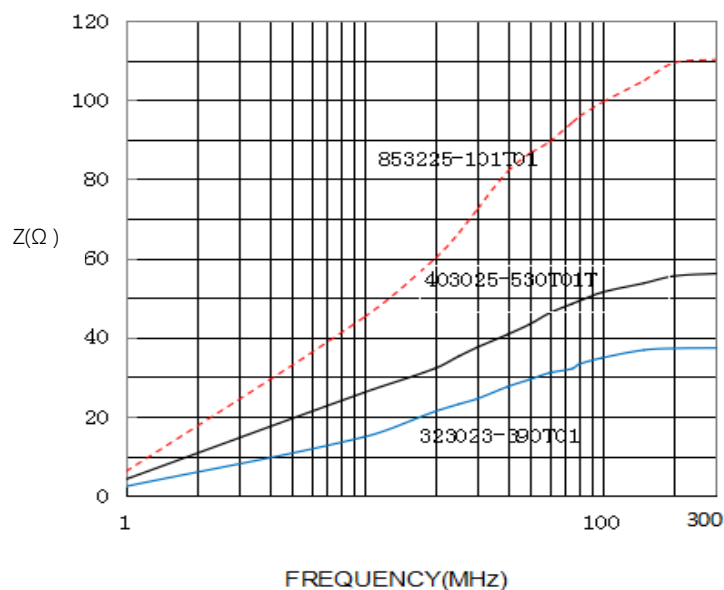

Features

- High common mode impedance at high frequency cause excellent noise suppression performance.
- CMSC series realizes small size and low profile.
- Operating temperature-40~+125°C (Including self-temperature rise)



CMSC-S

Applications

- USB2.0 of IEEE1394, PC, peripheral equipment, small digital AV equipment, etc.
- LVDS lines of Note PC, LCD
- Audio lines



CMSC-M

Dimensions(mm)

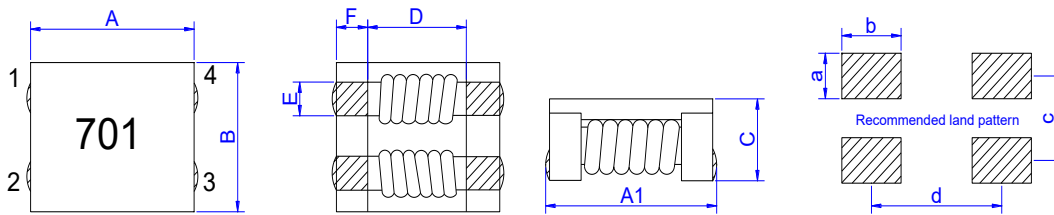

Schematics

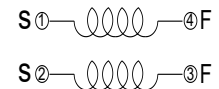

Type	A	A1	B	C	D	E	F	a	b	c	d	Packaging (pcs/reel)
CMSC4520S/M	4.7±0.5	5.0±0.5	4.5±0.5	2.2 max	2.7	1.0±0.2	1.0±0.2	1.5	1.5	2.0	3.7	1000
CMSC7060S/M	7.0±0.5	7.5±0.5	6.0±0.5	3.8 max	3.5	1.5±0.2	1.7±0.2	2.0	2.5	3.25	5.3	1500
CMSC9070S/M	9.0±0.5	9.5±0.5	7.0±0.5	4.8 max	5.6	1.8±0.2	1.7±0.2	2.0	2.75	3.5	7.2	700
CMSC1211S/M	12.0±0.5	12.5±0.5	10.8±0.5	6.4 max	7.0	2.7±0.2	2.5±0.2	3.2	3.0	5.25	9.5	500
CMSC1513S/M	15.0±0.5	15.5±0.5	13.0±0.5	6.6 max	9.8	2.6±0.2	2.5±0.2	3.0	3.6	6.0	12.5	350

Dimensions without tolerance are typical.

Product Identification

CMSC 7060 S - 701 T 01

① ② ③ ④ ⑤ ⑥

- ① Product Series No.
- ② Dimension symbol. 7060=7.0 x 6.0mm (L x H)
- ③ Internal control code. **M**:transparent brown cover, **S**:black plastic cover
- ④ Impedance value. 701=70×10¹Ω=700 Ω, 102=1000 Ω
- ⑤ Packing. T=Taping, B=Bulk.
- ⑥ Characteristic parameter level.

CMSC4520 Electrical Characteristics

Part Number	Impedance ① (Ω) at 100MHz		DCR (mΩ) ②	Insulation Resistance (MΩ)	Rated Voltage (V)	Rated ③ Current (A)
	typ	min	max	Min	max	max
CMSC4520□-900T01	90	60	35	10	50	3.8
CMSC4520□-151T01	150	90	40	10	50	3.5
CMSC4520□-231T01	230	180	45	10	50	3.2
CMSC4520□-301T01	300	200	45	10	50	3.0
CMSC4520□-401T01	400	300	50	10	50	2.5
CMSC4520□-701T01	700	500	59	10	50	2.2
CMSC4520□-901T01	900	650	68	10	50	2.1
CMSC4520□-102T01	1000	800	68	10	50	2.1
CMSC4520□-122T01	1200	1000	74	10	50	2.0
CMSC4520□-142T01	1400	1200	81	10	50	1.9

CMSC7060 Electrical Characteristics

Part Number	Impedance ① (Ω) at 100MHz		DCR (mΩ) ②	Insulation Resistance (MΩ)	Rated Voltage (V)	Rated ③ Current (A)
	typ	min	max	Min	max	max
CMSC7060□-700T01	70	40	5.0	10	125	15.0
CMSC7060□-101T01	140	100	10	10	125	9.0
CMSC7060□-301T01	300	225	10	10	125	5.0
CMSC7060□-501T01	500	275	10	10	125	5.0
CMSC7060□-701T01	700	500	15	10	125	4.0
CMSC7060□-102T01	1000	800	17	10	125	3.0
CMSC7060□-132T01	1300	910	21	10	125	2.5
CMSC7060□-222T01	2200	1500	53	10	125	1.5
CMSC7060□-272T01	2700	2000	63	10	125	1.0
CMSC7060□-302T01	3000	2500	75	10	125	0.9

CMSC9070 Electrical Characteristics

Part Number	Impedance ① (Ω) at 100MHz		DCR (mΩ) ②	Insulation Resistance (MΩ)	Rated Voltage (V)	Rated ③ Current (A)
	typ	min	max	Min	max	max
CMSC9070□-301T01	300	225	6.0	10	125	6.0
CMSC9070□-501T01	500	450	8.0	10	125	5.5
CMSC9070□-701T01	700	500	10	10	125	5.0
CMSC9070□-102T01	1000	750	13	10	125	4.0
CMSC9070□-222T01	2200	1700	50	10	125	3.0
CMSC9070□-272T01	2700	2000	80	10	125	2.0
CMSC9070□-302T01	3000	2500	85	10	125	2.0

All specifications are subject to change without notice.

CMSC1211 Electrical Characteristics

Part Number	Impedance (Ω) ①			DCR (mΩ) ②	Insulation Resistance (MΩ)	Rated Voltage (V)	Rated ③ Current (A)
	typ	min	TEST Frequency				
CMSC1211□-231T01	230	80	100MHz	2.0	10	125	10.0
CMSC1211□-301T01	300	200	100MHz	4.0	10	125	9.0
CMSC1211□-501T01	500	300	100MHz	5.5	10	125	8.0
CMSC1211□-701T01	700	500	100MHz	6.0	10	125	8.0
CMSC1211□-801T01	800	600	100MHz	8.0	10	125	8.0
CMSC1211□-102T01	1000	750	100MHz	14	10	125	6.0
CMSC1211□-252T01	2500	2200	10MHz	35	10	125	1.8
CMSC1211□-272T01	2700	2300	10MHz	50	10	125	1.5

CMSC1513 Electrical Characteristics

Part Number	Impedance ① (Ω) at 100MHz		DCR (mΩ) ②	Insulation Resistance (MΩ)	Rated Voltage (V)	Rated ③ Current (A)
	typ	min				
CMSC1513□-301T01	300	225	4.0	10	125	15.0
CMSC1513□-301T02	300	225	5.0	10	125	13.0
CMSC1513□-501T01	500	400	6.0	10	125	10.0
CMSC1513□-551T01	550	400	5.0	10	125	12.0
CMSC1513□-551T02	550	400	6.0	10	125	10.0
CMSC1513□-601T01	600	500	7.0	10	125	10.0
CMSC1513□-701T01	700	500	7.0	10	125	10.0
CMSC1513□-102T01	1000	800	10.0	10	125	9.0
CMSC1513□-152T01	1500	1200	23.0	10	125	5.0

Note:

- ① Impedance measured on a 4991A Keysight Technologies or equivalent.
- ② DCR measured on a micro-ohmmeter (Single winding) .
- ③ Rated Current: The DC current at which $\Delta t=40^{\circ}\text{C}$,measure pin1 to 2,short pin3,4 (at 25 $^{\circ}\text{C}$).

Common Mode Impedance TEST

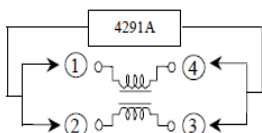

Features

- High common mode impedance at high frequency cause excellent noise suppression performance.
- CMDI series realizes small size and low profile.
- Operating temperature -40~+125°C (Including self-temperature rise)



Applications

- USB2.0 of IEEE1394, PC, peripheral equipment, small digital AV equipment, etc.
- LVDS lines of Note PC, LCD
- Audio lines



Dimensions(mm)

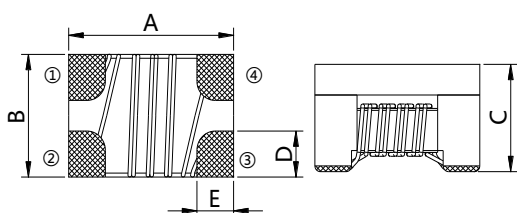

Schematic Diagram

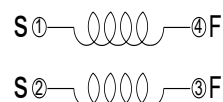

Type	A	B	C	D	E	Packaging (pcs/reel)
CMDI1608S	1.6±0.1	0.8±0.1	1.1±0.1	0.33	0.25	3000
CMDI2012S	2.0±0.2	1.2±0.2	1.2±0.2	0.5	0.5	2000
CMDI2520S	2.5±0.2	2.0±0.2	1.2±0.2	0.6	0.45	2000
CMDI3216S	3.2±0.2	1.6±0.2	1.8±0.2	0.6	0.6	2000
CMDI3216N	3.4±0.2	1.6±0.2	2.0±0.2	0.6	0.7	2000
CMDI3225L	3.2±0.2	2.5±0.2	2.2±0.2	0.9	0.8	2000
CMDI3225D	3.2±0.2	2.5±0.2	2.2±0.2	0.9	0.8	2000
CMDI4532C	4.5±0.2	3.2±0.2	2.8±0.5	1.2	1.0	500
CMDI4532T	4.5±0.2	3.2±0.2	2.8±0.5	1.2	1.0	500

Dimensions without tolerance are typical.

Product Identification

CMDI 3216 S - 221 T 01

① ② ③ ④ ⑤ ⑥

- ① Product Series No.
- ② Dimension symbol. 3216=3.2 x 1.6mm (L x H)
- ③ Internal control code.
- ④ Impedance value. 221=22×10¹ Ω=220 Ω; Inductance Value:510=51uH,101=100uH
- ⑤ Packing. T=Taping, B=Bulk
- ⑥ Characteristic parameter level.

CMDI1608S Electrical Characteristics

Part Number	Impedance ① Ω at 100MHz	DCR ② (mΩ) max	Insulation Resistance (MΩ) Min	Rated Voltage (V) max.	Rated ③ Current -mA
CMDI1608S-220T01	22±25%	110	10	20	500
CMDI1608S-900T01	90±25%	250	10	20	300

CMDI2012S Electrical Characteristics

Part Number	Impedance ① Ω at 100MHz	DCR ② (mΩ) max	Insulation Resistance (MΩ) Min	Rated Voltage (V) max.	Rated ③ Current -mA
CMDI2012S-500T01	50±25%	250	10	50	400
CMDI2012S-670T01	67±25%	250	10	50	400
CMDI2012S-700T01	70±25%	300	10	50	400
CMDI2012S-750T01	75±25%	300	10	50	400
CMDI2012S-900T01	90±25%	300	10	50	400
CMDI2012S-121T01	120±25%	300	10	50	370
CMDI2012S-161T01	160±25%	350	10	50	330
CMDI2012S-181T01	180±25%	350	10	50	330
CMDI2012S-221T01	220±25%	400	10	50	300
CMDI2012S-261T01	260±25%	400	10	50	300
CMDI2012S-301T01	300±25%	420	10	50	300
CMDI2012S-361T01	360±25%	450	10	50	280
CMDI2012S-371T01	370±25%	500	10	50	280
CMDI2012S-451T01	450±25%	500	10	50	250
CMDI2012S-601T01	600±25%	600	10	50	220
CMDI2012S-801T01	800±25%	880	10	50	300
CMDI2012S-901T01	900±25%	900	10	50	150
CMDI2012S-102T01	1000±25%	1300	10	50	150

CMDI2520S Electrical Characteristics

Part Number	Impedance ① Ω at 100MHz	DCR ② (mΩ) max	Insulation Resistance (MΩ) Min	Rated Voltage (V) max.	Rated ③ Current -mA
CMDI2520S-301T01	300±25%	200	10	50	400
CMDI2520S-451T01	450±25%	300	10	50	350
CMDI2520S-601T01	600±25%	380	10	50	330
CMDI2520S-102T01	1000±25%	500	10	50	240

CMDI3216N Electrical Characteristics

Part Number	Inductance ① uH at 100kHz/0.1V	DCR ② (Ω) max	Insulation Resistance (MΩ) Min	Rated Voltage (V) max.	Rated ③ Current -mA
CMDI3216N-400T01	40 MIN.	2.0	10	50	100
CMDI3216N-600T01	60 MIN.	1.1	10	50	200
CMDI3216N-600T02	60 MIN.	0.9	10	50	200
CMDI3216N-600T03	60 MIN.	1.7	10	50	200
CMDI3216N-900T01	90 MIN.	2.0	10	50	100

All specifications are subject to change without notice.

CMDI3216S Electrical Characteristics

Part Number	Impedance ① Ω at 100MHz	DCR ② (mΩ) max	Insulation Resistance (MΩ) Min	Rated Voltage (V) max.	Rated ③ Current (mA)
CMDI3216S-900T01	90±25%	300	10	50	370
CMDI3216S-121T01	120±25%	300	10	50	350
CMDI3216S-161T01	160±25%	400	10	50	340
CMDI3216S-221T01	220±25%	450	10	50	300
CMDI3216S-261T01	260±25%	500	10	50	310
CMDI3216S-361T01	370±25%	600	10	50	300
CMDI3216S-601T01	600±25%	800	10	50	260
CMDI3216S-801T01	800±25%	900	10	50	240
CMDI3216S-102T01	1000±25%	1000	10	50	230
CMDI3216S-142T01	1400±25%	1000	10	50	220
CMDI3216S-202T01	2000±25%	1200	10	50	200
CMDI3216S-222T01	2200±25%	1200	10	50	200

CMDI3225D Electrical Characteristics

Part Number	Impedance ① Ω at 100MHz	DCR ② (mΩ) max	Insulation Resistance (MΩ) Min	Rated Voltage (V) max.	Rated ③ Current -mA
CMDI3225D-800T01	80±25%	120	10	50	640
CMDI3225D-161T01	160±25%	150	10	50	480
CMDI3225D-271T01	270±25%	250	10	50	450
CMDI3225D-501T01	500±25%	300	10	50	1000
CMDI3225D-601T01	600±25%	200	10	50	1000
CMDI3225D-801T01	800±25%	350	10	50	350
CMDI3225D-102T01	1000±25%	350	10	50	480
CMDI3225D-102T02	1000±25%	100	10	50	1500

CMDI3225L Electrical Characteristics

Part Number	Inductance ① uH at 100kHz/0.1V	Impedance① Ω at 10MHz	DCR ② (mΩ) max	Insulation Resistance (MΩ) Min	Rated Voltage (V) max.	Rated ③ Current -mA
CMDI3225L-110T01	11+50%,-30%	300min.	400	10	50	300
CMDI3225L-220T01	22+50%,-30%	500min.	500	10	50	250
CMDI3225L-510T01	51+50%,-30%	1000min.	700	10	50	200
CMDI3225L-101T01	100+50%,-30%	2200min.	1500	10	50	150
CMDI3225L-201T01	200+50%,-30%	8000min.	4800	10	50	70

- ① Impedance measured on a 4991A Keysight Technologies or equivalent.
- ② DCR measured on a micro-ohmmeter (Single winding)
- ③ Rated Current: The DC current at which $\Delta t=40^{\circ}\text{C}$,measure pin1 to 2,short pin3,4 (at 25°C).

CMDI4532T Electrical Characteristics

Part Number	Impedance ① Ω at 100MHz MIN.	Impedance Ω at 100MHz Typ. ①	DCR ② (mΩ) max	Insulation Resistance (MΩ) Min	Rated Voltage (V) max.	Rated ③ Current -A
CMDI4532T-800T01	60	80	50	10	50	2.3
CMDI4532T-900T01	68	90	78	10	50	2.3
CMDI4532T-121T01	90	120	100	10	50	1.4
CMDI4532T-201T01	150	200	100	10	50	1.5
CMDI4532T-221T01	165	220	100	10	50	1.3
CMDI4532T-331T01	248	330	110	10	50	1.1
CMDI4532T-421T01	300	420	55	10	50	1.4
CMDI4532T-501T01	380	500	70	10	50	1.4
CMDI4532T-601T01	450	600	85	10	50	1.5
CMDI4532T-701T01	525	700	120	10	50	1.2
CMDI4532T-801T01	600	800	150	10	50	1.1
CMDI4532T-901T01	675	900	100	10	50	1.0
CMDI4532T-102T01	750	1000	130	10	50	1.0
CMDI4532T-142T01	1050	1400	100	10	50	0.9

CMDI4532C Electrical Characteristics

Part Number	Inductance uH at 100kHz	Impedance ① Ω at 10MHz typ.	Impedance Ω at 10MHz min①	DCR ② (Ω) max	Insulation Resistance (MΩ) Min	Rated Voltage (V) max.	Rated ③ Current (mA) Max.
CMDI4532C-100T01	10+50%/-30%	600	300	0.60	10	50	360
CMDI4532C-110T01	11+50%/-30%	600	300	0.60	10	50	360
CMDI4532C-220T01	22+50%/-30%	1200	500	1.00	10	50	310
CMDI4532C-510T01	51+50%/-30%	2800	1000	1.00	10	50	230
CMDI4532C-101T01	100+50%/-30%	5800	2000	2.00	10	50	200
CMDI4532C-201T01	200+50%/-30%	8000	5000	4.50	10	50	100

- ① Impedance measured on a 4991A Keysight Technologies or equivalent.
- ② DCR measured on a micro-ohmmeter (Single winding)
- ③ Rated Current: The DC current at which $\Delta t=40^{\circ}\text{C}$,measure pin1 to 2,short pin3,4 (at 25°C).

Common Mode Impedance TEST

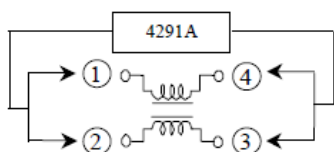

Dimensions(mm)

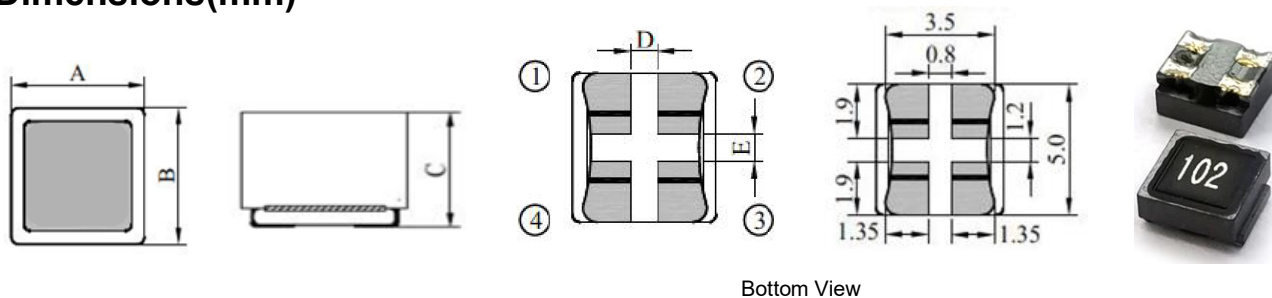

Bottom View

Type	A	B	C	D	E	F	G	H	I	Packaging (pcs/reel)
CMDR5020S	4.8±0.5	5.0±0.5	2.5 max	0.8	1.0±0.2	2.3	1.6	0.8	1.0	2500
CMDR5040S	4.8±0.5	5.0±0.5	3.8 max	0.8	1.0±0.2	2.3	1.6	0.8	1.0	1000

Dimensions without tolerance are typical.

Schematic Diagram

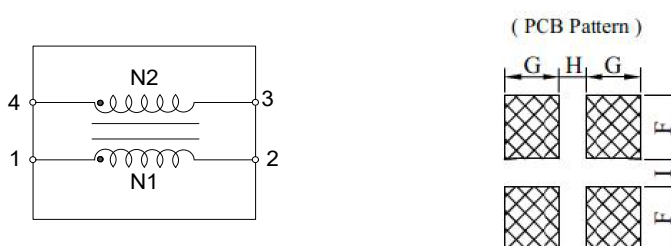

CMDR5020S Electrical Characteristics

Part Number	Impedance① (Ω) at 100MHz	Rated Voltage (VDC)Max.	Rated Current (A)Max. ②	DC Resistance (mΩ)Max. ③	Insulation Resistance (MΩ)Min.	Marking
CMDR5020S-101TS	100	50	6.0	13	10	101
CMDR5020S-251TS	250	50	5.0	20	10	251
CMDR5020S-501TS	500	50	4.0	27	10	501
CMDR5020S-102TS	1000	50	2.0	34	10	102
CMDR5020S-142TS	1400	50	1.5	56	10	142
CMDR5020S-152TS	1500	50	1.5	56	10	152

CMDR5040S Electrical Characteristics

Part Number	Impedance (Ω) at 100MHz Typ.	Rated Voltage (VDC)Max.	Rated Current (A)Max. ②	DC Resistance (mΩ) Max.	Insulation Resistance (MΩ) Min.	Marking
CMDR5040S-191TS	190	50	5.0	20	10	191
CMDR5040S-351TS	350	50	2.0	40	10	351
CMDR5040S-501TS	500	50	1.0	230	10	501
CMDR5040S-102TS	1000	50	1.5	60	10	102
CMDR5040S-152TS	1500	50	1.0	100	10	152
CMDR5040S-302TS	3000	50	0.5	200	10	302
CMDR5040S-402TS	4000	50	0.2	300	10	402

- ① Impedance measured on a 4991A Keysight Technologies or equivalent.
- ② Rated Current: The DC current at which Δt=40°C,measure pin1 to 2,short pin3,4 (at 25°C).
- ③ DCR measured on a micro-ohmmeter (Single winding)

All specifications are subject to change without notice.

Dimensions(mm)

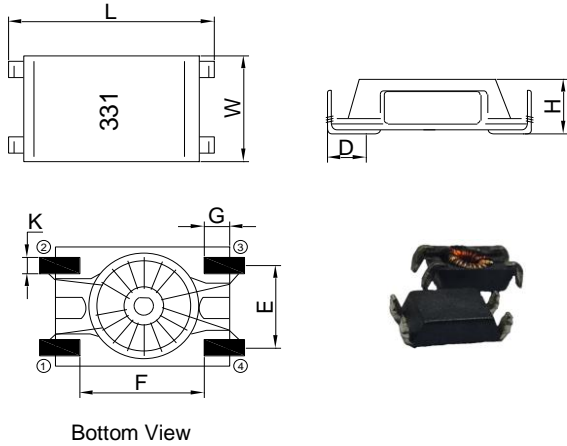

Recommended Patterns

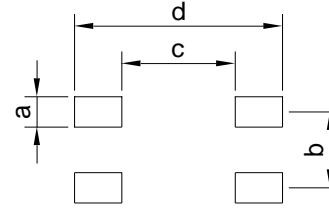

L	W	H	D	E	F	G	K	a	b	c	d
6.5Max.	3.6±0.15	1.65±0.15	0.9Min	2.5	3.4	0.8Max.	0.55	1.0	2.5	3.6	6.6

Dimensions do not include solder on the Pins

Schematics

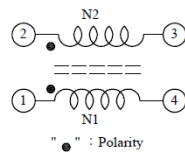

Electrical Characteristics

Part Number	L (uH) 10kHz/0.25V	L1-L2 (uH)max.at 1MHz/0.1V	RDC (Ω) ^① max. N1=N2	Rated current (mA) ^②
CMTR0602S-100T01	10±50%	0.58	0.24	300
CMTR0602S-470T01	47±50%	0.28	0.16	300
CMTR0602S-510T01	51±50%	0.27	0.16	300
CMTR0602S-820T01	82±50%	0.37	0.25	300
CMTR0602S-101T01	100±50%	0.53	0.25	300
CMTR0602S-181T01	180±50%	0.76	0.25	300
CMTR0602S-221T01	220±50%	0.95	0.28	300
CMTR0602S-331T01	330±50%	1.30	0.30	300

- ① RDC:Single winding
- ② Rated current based on Temp. rise 20°Cmax. (Ta=25°C)
- ③ HI-POT Tested at 250Vac 60Hz 3mA 1s.
- ④ Nominal voltage : 60Vdc

Packaging

Packaging Quantity: 2500 pcs per Reel.

All specifications are subject to change without notice.

Dimensions(mm)

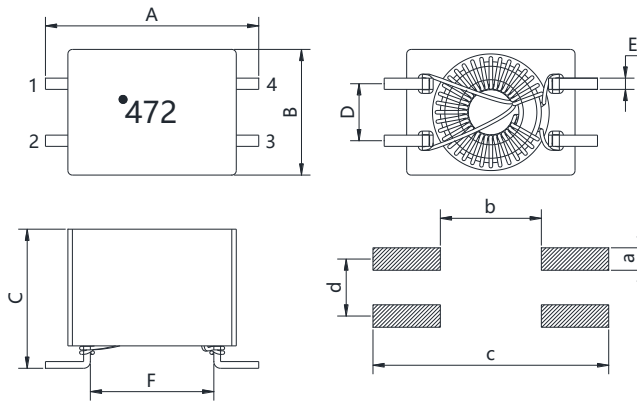

Schematics

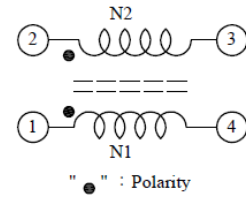

A	B	C	D	E	F	a	b	c	d
9.50Max	5.60Max	5.20Max	2.54Typ	0.50Typ	5.50Typ	1.00Typ	4.50Typ	10.5Typ	2.54Typ

Dimensions do not include solder on the pins

Electrical Characteristics

Part Number	Inductance +50%/-30% (uH) ^①	Leakage Inductance L1-4(2-3short) (uH)	DC ^② Resistance (mΩ) Max	Rated current (mA) ^③	Impedance (Ω) Min ^④	Freq. range (MHz)	Rated Volt. (Vdc)Max.
CMTR0904S-110T01	11	0.08	110	500	160	20-300	50V
CMTR0904S-250T01	25	0.15	190	500	450	20-150	50V
CMTR0904S-510T01	51	0.20	290	500	800	20-100	50V
CMTR0904S-101T01	100	0.25	95	500	600	3-20	50V
CMTR0904S-471T01	470	0.28	270	500	1200	2-15	50V
CMTR0904S-102T01	1000	0.28	290	500	1800	1-10	50V
CMTR0904S-222T01	2200	0.29	380	500	3000	0.8-5	50V
CMTR0904S-472T01	4700	0.30	680	200	5000	0.5-3	50V

① Inductance tested at 100kHz/0.1V

② DCR measured on a micro-ohmmeter (Single winding)

③ Rated Current: The DC current at which $\Delta t=40^{\circ}\text{C}$,measure pin1 to 2,short pin3,4 (at 25 $^{\circ}\text{C}$).

④ Impedance measured on a 4991A Keysight Technologies or equivalent.

Packaging

Packaging Quantity: 1500 pcs per Reel.

Dimensions(mm)

Recommended Patterns

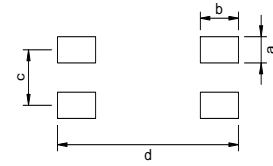
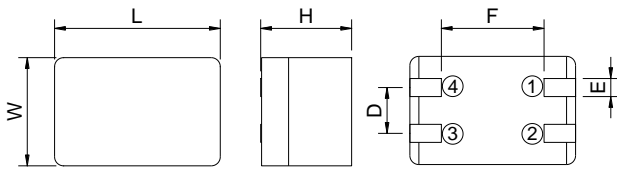

L	W	H	E	D	F	a	b	c	d
9.2±0.3	6.0±0.3	5.0±0.3	1.0 typ.	2.54 typ.	5.6 typ.	1.2	2.0	2.54	9.5

Schematics

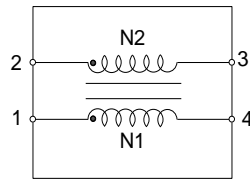

Electrical Characteristics

Part Number	Inductance (uH)①	DC Resistance (Ω) Max②	Rated current (A) ③	Impedance (Ω) Min	Freq. range (MHz)	Rated Volt. (Vdc)Max.	IR(Ω) Min
CMTR0905S-100T01	10+50%/-30%	1KHz/0.1V	0.075	1.6	300	20~200	10M
CMTR0905S-250T01	25+50%/-30%	1KHz/0.1V	0.13	1.0	600	5~150	10M
CMTR0905S-400T01	40+50%/-30%	1KHz/0.1V	0.22	0.9	800	20~100	10M
CMTR0905S-510T01	51+50%/-30%	1KHz/0.1V	0.16	0.8	1000	20~100	10M
CMTR0905S-251T01	250 ±50%	100KHz/5mV	0.13	1.2	600	5~50	10M
CMTR0905S-471T01	470 ±50%	100KHz/5mV	0.14	1.1	800	1~50	10M
CMTR0905S-501T01	500 ±50%	100KHz/5mV	0.15	1.0	900	1~40	10M
CMTR0905S-102T01	1000 ±50%	1KHz/0.1V	0.31	0.8	1000	1~30	10M
CMTR0905S-202T01	2000 ±50%	1KHz/0.1V	0.42	0.6	2000	1~10	10M
CMTR0905S-472T01	4700 ±50%	1KHz/0.1V	0.85	0.4	3000	0.3~3	10M
CMTR0905S-652T01	6500 ±50%	1KHz/0.1V	1.05	0.3	4000	0.3~2	10M

- ① Inductance measured on a 4284A or equivalent.
- ② DCR measured on a micro-ohmmeter (Single winding) .
- ③ Rated Current: The DC current at which $\Delta t=40^{\circ}\text{C}$,measure pin1 to 2,short pin3,4 (at 25°C).

Packaging Q'ty: 1000pcs/reel

KTW-C Series Ceramic Chip Wire Wound Inductors

Dimensions(mm)

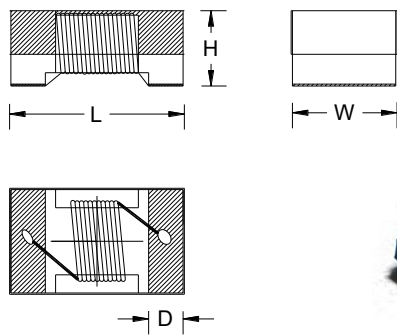

Recommended Patterns

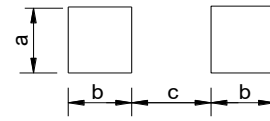

Type	L	W	H	D	a	b	c	Packaging (pcs/reel)
KTW0402UC	1.19 Max.	0.66 Max.	0.6 Max.	0.23	0.66	0.36	0.46	5000
KTW0603UC	1.78 Max.	1.10 Max.	0.95 Max.	0.30	1.02	0.64	0.64	4000
KTW0805UC	2.30 Max.	1.70 Max.	1.52 Max.	0.50	1.78	1.02	0.76	3000
KTW1008UC	2.92 Max.	2.79 Max.	2.10Max.	0.50	2.54	1.02	1.27	2000
KTW1210HC	3.50 Max.	2.90 Max.	2.25 Max.	0.50	2.54	1.02	1.78	2000

Dimensions without tolerance are typical.

Product Identification

KTW **0402** **UC** **1N0** □ **S** **C**
 ① ② ③ ④ ⑤ ⑥ ⑦

- ① Wire Wound Inductor Series
- ② Dimensions : 0402(inch)=1005(mm)=1.0x0.5mm
- ③ Material : UC Ceramic core
- ④ Inductance : 1N0=1.0nH, 010=10nH, R10=100nH, 1R0=1.0μH, 100=10μH
- ⑤ Tolerance : G=±2% ; J=±5% ; K=±10%
- ⑥ Terminal : G(Gold),S(Tin)
- ⑦ Packaging type : C=Tape& Reel,B=Bulk

KTW0402UC Electrical Characteristics

Part Number	Tolerance	Inductance (nH) ①	Inductance Test Conditions	Q value min.	Q value Test frequency (MHz)	DCR(Ω) max. ②	Rated current (mA) ③	SRF(MHz) min.
KTW0402UC1N0□SC	K	1.0	250MHz/0.5V	13	250	0.045	1360	10000
KTW0402UC1N2□SC	K	1.2	250MHz/0.5V	8	250	0.135	640	10000
KTW0402UC1N8□SC	K	1.8	250MHz/0.5V	16	250	0.070	1040	6000
KTW0402UC1N9□SC	K	1.9	250MHz/0.5V	16	250	0.070	1040	6000
KTW0402UC2N0□SC	K	2.0	250MHz/0.5V	18	250	0.070	1040	6000
KTW0402UC2N2□SC	K	2.2	250MHz/0.5V	18	250	0.070	960	6000
KTW0402UC2N4□SC	K	2.4	250MHz/0.5V	16	250	0.080	790	6000
KTW0402UC2N5□SC	K	2.5	250MHz/0.5V	15	250	0.120	640	6000
KTW0402UC2N7□SC	K	2.7	250MHz/0.5V	15	250	0.120	640	6000
KTW0402UC2N9□SC	K	2.9	250MHz/0.5V	8	250	0.300	400	6000
KTW0402UC3N3□SC	J、K	3.3	250MHz/0.5V	20	250	0.066	840	6000
KTW0402UC3N6□SC	G、J、K	3.6	250MHz/0.5V	20	250	0.066	840	6000
KTW0402UC3N9□SC	G、J、K	3.9	250MHz/0.5V	20	250	0.066	840	6000
KTW0402UC4N3□SC	J、K	4.3	250MHz/0.5V	20	250	0.091	700	6000
KTW0402UC4N7□SC	G、J、K	4.7	250MHz/0.5V	18	250	0.200	640	4500
KTW0402UC5N1□SC	G、J、K	5.1	250MHz/0.5V	18	250	0.083	800	4800
KTW0402UC5N6□SC	G、J、K	5.6	250MHz/0.5V	20	250	0.083	760	4800
KTW0402UC6N2□SC	G、J、K	6.2	250MHz/0.5V	23	250	0.083	760	4800
KTW0402UC6N8□SC	G、J、K	6.8	250MHz/0.5V	23	250	0.260	680	4800
KTW0402UC7N5□SC	G、J、K	7.5	250MHz/0.5V	23	250	0.100	680	4800
KTW0402UC8N2□SC	G、J、K	8.2	250MHz/0.5V	25	250	0.100	680	4400
KTW0402UC8N7□SC	G、J、K	8.7	250MHz/0.5V	25	250	0.200	480	4100
KTW0402UC9N0□SC	G、J、K	9.0	250MHz/0.5V	25	250	0.100	680	4160
KTW0402UC9N5□SC	G、J、K	9.5	250MHz/0.5V	25	250	0.200	480	4000
KTW0402UC010□SC	G、J、K	10	250MHz/0.5V	25	250	0.20	480	3900
KTW0402UC011□SC	G、J、K	11	250MHz/0.5V	25	250	0.120	640	3680
KTW0402UC012□SC	J、K	12	250MHz/0.5V	25	250	0.120	640	3600
KTW0402UC013□SC	G、J、K	13	250MHz/0.5V	25	250	0.210	440	3450
KTW0402UC015□SC	G、J、K	15	250MHz/0.5V	25	250	0.300	560	3280
KTW0402UC016□SC	G、J、K	16	250MHz/0.5V	25	250	0.220	560	3100
KTW0402UC018□SC	G、J、K	18	250MHz/0.5V	25	250	0.230	420	3100
KTW0402UC019□SC	G、J、K	19	250MHz/0.5V	25	250	0.200	480	3040
KTW0402UC020□SC	G、J、K	20	250MHz/0.5V	25	250	0.250	420	3000
KTW0402UC022□SC	G、J、K	22	250MHz/0.5V	25	250	0.300	400	2800
KTW0402UC023□SC	G、J、K	23	250MHz/0.5V	22	250	0.380	310	2720
KTW0402UC024□SC	G、J、K	24	250MHz/0.5V	25	250	0.300	400	2700
KTW0402UC027□SC	G、J、K	27	250MHz/0.5V	24	250	0.520	280	2480
KTW0402UC030□SC	G、J、K	30	250MHz/0.5V	25	250	0.500	400	2350
KTW0402UC033□SC	G、J、K	33	250MHz/0.5V	24	250	0.650	350	2350
KTW0402UC036□SC	G、J、K	36	250MHz/0.5V	25	250	0.600	250	2320
KTW0402UC039□SC	G、J、K	39	250MHz/0.5V	25	250	0.750	200	2100
KTW0402UC040□SC	G、J、K	40	250MHz/0.5V	25	250	0.600	220	2240
KTW0402UC043□SC	J、K	43	250MHz/0.5V	25	250	0.810	100	2030
KTW0402UC047□SC	G、J、K	47	250MHz/0.5V	25	250	0.830	150	2100
KTW0402UC051□SC	J、K	51	250MHz/0.5V	25	250	0.820	100	1750
KTW0402UC056□SC	G、J、K	56	250MHz/0.5V	25	250	0.97	100	1760

All specifications are subject to change without notice.

KTW0402UC Electrical Characteristics

Part Number	Tolerance	Inductance (nH) ①	Inductance Test Conditions	Q value min.	Q value Test frequency (MHz)	DCR(Ω) max. ②	Rated current (mA) ③	SRF(MHz) min.
KTW0402UC068□SC	G、J、K	68	250MHz/0.5V	25	250	1.12	100	1620
KTW0402UC075□SC	G、J、K	75	250MHz/0.5V	25	250	1.63	50	1400
KTW0402UC082□SC	G、J、K	82	250MHz/0.5V	25	250	1.70	50	1260
KTW0402UCR10□SC	G、J、K	100	250MHz/0.5V	25	250	2.00	30	1160
KTW0402UCR12□SC	G、J、K	120	250MHz/0.5V	25	250	2.20	30	1100

KTW0603UC Electrical Characteristics

Part Number	Tolerance	Inductance (nH) ①	Inductance Test Conditions	Q value min.	Q value Test frequency (MHz)	DCR(Ω) max. ②	Rated current (mA) ③	SRF(MHz) min.
KTW0603UC1N6□SC	K	1.6	250MHz/0.5V	18	250	0.04	700	12500
KTW0603UC1N7□SC	J、K	1.7	250MHz/0.5V	18	250	0.045	700	12500
KTW0603UC1N8□SC	K	1.8	250MHz/0.5V	16	250	0.045	700	12500
KTW0603UC2N0□SC	J、K	2.0	250MHz/0.5V	12	250	0.09	700	10000
KTW0603UC2N2□SC	K	2.2	250MHz/0.5V	12	250	0.09	700	10000
KTW0603UC3N3□SC	K	3.3	250MHz/0.5V	20	250	0.075	700	5900
KTW0603UC3N6□SC	G、J、K	3.6	250MHz/0.5V	22	250	0.075	700	5900
KTW0603UC3N9□SC	G、J、K	3.9	250MHz/0.5V	22	250	0.08	700	6900
KTW0603UC4N3□SC	G、J、K	4.3	250MHz/0.5V	22	250	0.075	700	5900
KTW0603UC4N7□SC	G、J、K	4.7	250MHz/0.5V	20	250	0.116	700	5800
KTW0603UC5N1□SC	G、J、K	5.1	250MHz/0.5V	20	250	0.12	700	5700
KTW0603UC5N6□SC	K	5.6	250MHz/0.5V	18	250	0.20	700	5700
KTW0603UC6N0□SC	G、J、K	6.0	250MHz/0.5V	27	250	0.11	700	5700
KTW0603UC6N2□SC	G、J、K	6.2	250MHz/0.5V	27	250	0.11	700	5700
KTW0603UC6N8□SC	G、J、K	6.8	250MHz/0.5V	27	250	0.11	700	5800
KTW0603UC7N5□SC	G、J、K	7.5	250MHz/0.5V	28	250	0.11	700	4800
KTW0603UC8N2□SC	G、J、K	8.2	250MHz/0.5V	28	250	0.12	700	4700
KTW0603UC8N7□SC	G、J、K	8.7	250MHz/0.5V	28	250	0.12	700	4600
KTW0603UC9N1□SC	G、J、K	9.1	250MHz/0.5V	26	250	0.15	700	4500
KTW0603UC9N5□SC	G、J、K	9.5	250MHz/0.5V	26	250	0.15	700	5400
KTW0603UC010□SC	G、J、K	10	250MHz/0.5V	31	250	0.13	700	4800
KTW0603UC011□SC	G、J、K	11	250MHz/0.5V	33	250	0.13	700	4000
KTW0603UC012□SC	G、J、K	12	250MHz/0.5V	35	250	0.13	700	4000
KTW0603UC013□SC	G、J、K	13	250MHz/0.5V	30	250	0.14	700	4000
KTW0603UC014□SC	G、J、K	14	250MHz/0.5V	35	250	0.14	700	4000
KTW0603UC015□SC	G、J、K	15	250MHz/0.5V	30	250	0.15	700	4000
KTW0603UC016□SC	G、J、K	16	250MHz/0.5V	34	250	0.16	700	3300
KTW0603UC018□SC	G、J、K	18	250MHz/0.5V	35	250	0.17	700	3100
KTW0603UC020□SC	G、J、K	20	250MHz/0.5V	38	250	0.19	700	3000
KTW0603UC022□SC	G、J、K	22	250MHz/0.5V	38	250	0.19	700	3000
KTW0603UC024□SC	G、J、K	24	250MHz/0.5V	37	250	0.20	700	2650
KTW0603UC025□SC	G、J、K	25	250MHz/0.5V	38	250	0.21	700	2600
KTW0603UC027□SC	G、J、K	27	250MHz/0.5V	36	250	0.22	600	2800
KTW0603UC030□SC	G、J、K	30	250MHz/0.5V	37	250	0.22	600	2250
KTW0603UC033□SC	G、J、K	33	250MHz/0.5V	36	250	0.22	600	2300

All specifications are subject to change without notice.

KTW0603UC Electrical Characteristics

Part Number	Tolerance	Inductance (nH) ①	Inductance Test Conditions	Q value min.	Q value Test frequency (MHz)	DCR(Ω) max. ②	Rated current (mA) ③	SRF(MHz) min.
KTW0603UC036□SC	G、J、K	36	250MHz/0.5V	36	250	0.25	600	2080
KTW0603UC039□SC	G、J、K	39	250MHz/0.5V	40	250	0.25	600	2200
KTW0603UC043□SC	G、J、K	43	250MHz/0.5V	36	250	0.28	600	2000
KTW0603UC049□SC	G、J、K	49	200MHz/0.5V	36	200	0.28	600	2000
KTW0603UC051□SC	G、J、K	51	200MHz/0.5V	36	200	0.28	600	1900
KTW0603UC056□SC	G、J、K	56	200MHz/0.5V	38	200	0.28	600	1900
KTW0603UC068□SC	G、J、K	68	200MHz/0.5V	36	200	0.34	600	1700
KTW0603UC072□SC	G、J、K	72	150MHz/0.5V	34	150	0.53	400	1700
KTW0603UC075□SC	G、J、K	75	150MHz/0.5V	30	150	0.60	400	1400
KTW0603UC082□SC	G、J、K	82	150MHz/0.5V	34	150	0.55	400	1700
KTW0603UC091□SC	G、J、K	91	150MHz/0.5V	30	150	0.63	400	1400
KTW0603UCR10□SC	G、J、K	100	150MHz/0.5V	30	150	0.63	400	1400
KTW0603UCR11□SC	G、J、K	110	150MHz/0.5V	32	150	0.67	300	1350
KTW0603UCR12□SC	G、J、K	120	150MHz/0.5V	32	150	0.73	300	1300
KTW0603UCR15□SC	G、J、K	150	150MHz/0.5V	28	150	0.80	280	990
KTW0603UCR16□SC	J、K	160	100MHz/0.5V	25	100	1.25	250	990
KTW0603UCR18□SC	G、J、K	180	100MHz/0.5V	25	100	1.45	240	990
KTW0603UCR20□SC	G、J、K	200	100MHz/0.5V	25	100	1.55	200	900
KTW0603UCR22□SC	G、J、K	220	100MHz/0.5V	25	100	2.10	200	900
KTW0603UCR25□SC	G、J、K	250	100MHz/0.5V	25	100	3.55	120	822
KTW0603UCR27□SC	G、J、K	270	100MHz/0.5V	24	100	2.30	170	900
KTW0603UCR30□SC	G、J、K	300	100MHz/0.5V	24	100	3.00	100	1000
KTW0603UCR33□SC	G、J、K	330	100MHz/0.5V	25	100	3.89	100	900
KTW0603UCR39□SC	G、J、K	390	100MHz/0.5V	25	100	4.35	100	800
KTW0603UCR47□SC	G、J、K	470	100MHz/0.5V	25	100	7.00	75	700

KTW0805UC Electrical Characteristics

Part Number	Tolerance	Inductance (nH) ①	Inductance Test Conditions	Q value min.	Q value Test frequency (MHz)	DCR(Ω) max. ②	Rated current (mA) ③	SRF(MHz) min.
KTW0805UC2N2□SC	K	2.2	250MHz/0.5V	50	1500	0.03	800	8500
KTW0805UC2N5□SC	J、K	2.5	250MHz/0.5V	40	1500	0.04	800	8000
KTW0805UC2N7□SC	G、J、K	2.7	250MHz/0.5V	50	1500	0.045	800	8000
KTW0805UC3N0□SC	J、K	3.0	250MHz/0.5V	35	1500	0.09	600	8000
KTW0805UC3N3□SC	K	3.3	250MHz/0.5V	35	1500	0.09	600	7900
KTW0805UC4N7□SC	K	4.7	250MHz/0.5V	40	1000	0.05	600	6000
KTW0805UC5N1□SC	G、J、K	5.1	250MHz/0.5V	50	1000	0.05	600	5800
KTW0805UC5N4□SC	G、J、K	5.4	250MHz/0.5V	50	1000	0.05	600	5800
KTW0805UC5N6□SC	G、J、K	5.6	250MHz/0.5V	50	1000	0.065	600	5500
KTW0805UC6N2□SC	G、J、K	6.2	250MHz/0.5V	50	1000	0.11	600	5500
KTW0805UC6N8□SC	G、J、K	6.8	250MHz/0.5V	50	1000	0.11	600	5500
KTW0805UC7N5□SC	G、J、K	7.5	250MHz/0.5V	35	1000	0.15	600	4700
KTW0805UC7N8□SC	G、J、K	7.8	250MHz/0.5V	35	1000	0.20	600	4700
KTW0805UC8N2□SC	G、J、K	8.2	250MHz/0.5V	35	1000	0.20	600	4700
KTW0805UC010□SC	G、J、K	10	250MHz/0.5V	50	500	0.15	600	4200

All specifications are subject to change without notice.

KTW0805UC Electrical Characteristics

Part Number	Tolerance	Inductance (nH) ①	Inductance Test Conditions	Q value min.	Q value Test frequency (MHz)	DCR(Ω) max. ②	Rated current (mA) ③	SRF(MHz) min.
KTW0805UC011□SC	G、J、K	11	250MHz/0.5V	50	500	0.15	600	4000
KTW0805UC012□SC	G、J、K	12	250MHz/0.5V	50	500	0.15	600	4000
KTW0805UC014□SC	G、J、K	14	250MHz/0.5V	50	500	0.16	600	3500
KTW0805UC015□SC	G、J、K	15	250MHz/0.5V	45	500	0.17	600	3400
KTW0805UC016□SC	G、J、K	16	250MHz/0.5V	55	500	0.10	600	3400
KTW0805UC018□SC	G、J、K	18	250MHz/0.5V	55	500	0.20	600	3300
KTW0805UC020□SC	G、J、K	20	250MHz/0.5V	55	500	0.22	500	2800
KTW0805UC022□SC	G、J、K	22	250MHz/0.5V	55	500	0.22	500	2600
KTW0805UC024□SC	G、J、K	24	250MHz/0.5V	50	500	0.23	500	2500
KTW0805UC025□SC	G、J、K	25	250MHz/0.5V	50	500	0.24	500	2500
KTW0805UC027□SC	G、J、K	27	250MHz/0.5V	55	500	0.25	500	2500
KTW0805UC030□SC	G、J、K	30	250MHz/0.5V	55	500	0.26	500	2100
KTW0805UC033□SC	G、J、K	33	250MHz/0.5V	55	500	0.27	500	2050
KTW0805UC036□SC	G、J、K	36	250MHz/0.5V	55	500	0.28	500	2000
KTW0805UC039□SC	G、J、K	39	250MHz/0.5V	55	500	0.29	500	2000
KTW0805UC043□SC	G、J、K	43	250MHz/0.5V	50	500	0.30	500	1800
KTW0805UC047□SC	G、J、K	47	200MHz/0.5V	55	500	0.31	500	1650
KTW0805UC050□SC	G、J、K	50	200MHz/0.5V	55	500	0.34	500	1600
KTW0805UC051□SC	G、J、K	51	200MHz/0.5V	55	500	0.34	500	1600
KTW0805UC052□SC	G、J、K	52	200MHz/0.5V	55	500	0.34	500	1600
KTW0805UC053□SC	G、J、K	53	200MHz/0.5V	55	500	0.34	500	1600
KTW0805UC054□SC	G、J、K	54	200MHz/0.5V	55	500	0.34	500	1550
KTW0805UC056□SC	G、J、K	56	200MHz/0.5V	55	500	0.34	500	1550
KTW0805UC058□SC	G、J、K	58	200MHz/0.5V	55	500	0.38	500	1500
KTW0805UC060□SC	G、J、K	60	200MHz/0.5V	55	500	0.38	500	1500
KTW0805UC062□SC	G、J、K	62	200MHz/0.5V	55	500	0.38	500	1500
KTW0805UC068□SC	G、J、K	68	200MHz/0.5V	55	500	0.38	500	1450
KTW0805UC070□SC	G、J、K	70	200MHz/0.5V	55	500	0.38	500	1400
KTW0805UC072□SC	G、J、K	72	200MHz/0.5V	55	500	0.38	500	1400
KTW0805UC074□SC	G、J、K	74	200MHz/0.5V	55	500	0.40	400	1400
KTW0805UC075□SC	G、J、K	75	200MHz/0.5V	55	500	0.40	400	1400
KTW0805UC078□SC	G、J、K	78	200MHz/0.5V	55	500	0.42	400	1400
KTW0805UC080□SC	G、J、K	82	150MHz/0.5V	55	500	0.42	400	1300
KTW0805UC086□SC	G、J、K	86	150MHz/0.5V	55	500	0.45	400	1200
KTW0805UC091□SC	G、J、K	91	150MHz/0.5V	50	500	0.46	400	1100
KTW0805UC095□SC	G、J、K	95	150MHz/0.5V	50	500	0.46	400	1100
KTW0805UCR10□SC	G、J、K	100	150MHz/0.5V	50	500	0.46	400	1200
KTW0805UCR11□SC	G、J、K	110	150MHz/0.5V	45	250	0.51	400	1100
KTW0805UCR12□SC	G、J、K	120	150MHz/0.5V	45	250	0.51	400	1100
KTW0805UCR14□SC	G、J、K	140	150MHz/0.5V	45	250	0.56	400	950
KTW0805UCR15□SC	G、J、K	150	100MHz/0.5V	45	250	0.56	400	920
KTW0805UCR18□SC	G、J、K	180	100MHz/0.5V	45	250	0.64	400	870
KTW0805UCR20□SC	G、J、K	200	100MHz/0.5V	40	250	1.10	400	850
KTW0805UCR22□SC	G、J、K	220	100MHz/0.5V	40	250	1.05	400	850
KTW0805UCR23□SC	G、J、K	230	100MHz/0.5V	40	250	1.10	350	850
KTW0805UCR24□SC	G、J、K	240	100MHz/0.5V	40	250	1.10	350	850

All specifications are subject to change without notice.

KTW0805UC Electrical Characteristics

Part Number	Tolerance	Inductance (nH) ①	Inductance Test Conditions	Q value min.	Q value Test frequency (MHz)	DCR(Ω) max. ②	Rated current (mA) ③	SRF(MHz) min.
KTW0805UCR25□SC	G、J、K	250	100MHz/0.5V	40	250	1.40	350	650
KTW0805UCR27□SC	G、J、K	270	100MHz/0.5V	40	250	1.10	350	650
KTW0805UCR29□SC	G、J、K	290	100MHz/0.5V	40	250	1.55	350	600
KTW0805UCR30□SC	G、J、K	300	100MHz/0.5V	40	250	1.55	350	600
KTW0805UCR33□SC	G、J、K	330	100MHz/0.5V	40	250	1.40	310	600
KTW0805UCR36□SC	G、J、K	360	100MHz/0.5V	40	250	1.50	290	560
KTW0805UCR39□SC	G、J、K	390	100MHz/0.5V	40	250	1.50	290	560
KTW0805UCR43□SC	J、K	430	100MHz/0.5V	33	100	2.00	260	420
KTW0805UCR47□SC	J、K	470	50MHz/0.5V	33	100	2.00	250	375
KTW0805UCR51□SC	J、K	510	25MHz/0.5V	30	100	3.20	150	530
KTW0805UCR56□SC	J、K	560	25MHz/0.5V	23	50	1.90	230	340
KTW0805UCR62□SC	J、K	620	25MHz/0.5V	23	50	2.08	200	320
KTW0805UCR68□SC	J、K	680	25MHz/0.5V	23	50	2.10	190	300
KTW0805UCR75□SC	J、K	750	25MHz/0.5V	23	50	2.12	180	280
KTW0805UCR82□SC	J、K	820	25MHz/0.5V	23	50	2.14	180	250
KTW0805UCR91□SC	J、K	910	25MHz/0.5V	20	50	2.28	180	220
KTW0805UC1R0□SC	J、K	1000	25MHz/0.5V	20	50	2.40	170	200
KTW0805UC1R2□SC	J、K	1200	7.9MHz/0.5V	18	50	2.55	170	180
KTW0805UC1R5□SC	J、K	1500	7.9MHz/0.5V	18	50	2.80	160	170
KTW0805UC1R8□SC	J、K	1800	7.9MHz/0.5V	18	50	3.80	150	140
KTW0805UC2R2□SC	J、K	2200	7.9MHz/0.5V	16	7.9	4.20	150	50

KTW1008UC Electrical Characteristics

Part Number	Tolerance	Inductance (nH) ①	Inductance Test Conditions	Q value min.	Q value Test frequency (MHz)	DCR(Ω) max. ②	Rated current (mA) ③	SRF(MHz) min.
KTW1008UC3N9□SC	J、K	3.9	50MHz/0.5V	50	1500	0.035	1000	6000
KTW1008UC4N3□SC	J、K	4.3	50MHz/0.5V	50	1500	0.04	1000	6000
KTW1008UC4N7□SC	J、K	4.7	50MHz/0.5V	50	1500	0.045	1000	6000
KTW1008UC5N6□SC	J、K	5.6	50MHz/0.5V	30	1000	0.18	1000	6000
KTW1008UC010□SC	G、J、K	10	50MHz/0.5V	50	500	0.08	1000	4100
KTW1008UC012□SC	G、J、K	12	50MHz/0.5V	50	500	0.09	1000	3300
KTW1008UC015□SC	G、J、K	15	50MHz/0.5V	45	500	0.15	1000	2500
KTW1008UC018□SC	G、J、K	18	50MHz/0.5V	50	350	0.11	1000	2500
KTW1008UC020□SC	G、J、K	20	50MHz/0.5V	50	350	0.12	1000	2400
KTW1008UC022□SC	G、J、K	22	50MHz/0.5V	55	350	0.12	1000	2400
KTW1008UC024□SC	G、J、K	24	50MHz/0.5V	55	350	0.12	1000	2400
KTW1008UC027□SC	G、J、K	27	50MHz/0.5V	55	350	0.13	1000	1600
KTW1008UC033□SC	G、J、K	33	50MHz/0.5V	60	350	0.14	1000	1600
KTW1008UC036□SC	G、J、K	36	50MHz/0.5V	60	350	0.14	1000	1550
KTW1008UC039□SC	G、J、K	39	50MHz/0.5V	60	350	0.15	1000	1500
KTW1008UC047□SC	G、J、K	47	50MHz/0.5V	65	350	0.16	1000	1500
KTW1008UC051□SC	G、J、K	51	50MHz/0.5V	65	350	0.17	1000	1100
KTW1008UC056□SC	G、J、K	56	50MHz/0.5V	65	350	0.18	1000	1100
KTW1008UC068□SC	G、J、K	68	50MHz/0.5V	65	350	0.20	1000	1000

All specifications are subject to change without notice.

KTW1008UC Electrical Characteristics

Part Number	Tolerance	Inductance (nH) ①	Inductance Test Conditions	Q value min.	Q value Test frequency (MHz)	DCR(Ω) max. ②	Rated current (mA) ③	SRF(MHz) min.
KTW1008UC075□SC	G、J、K	75	50MHz/0.5V	60	350	0.20	1000	1000
KTW1008UC082□SC	G、J、K	82	50MHz/0.5V	60	350	0.22	1000	1000
KTW1008UC090□SC	G、J、K	90	50MHz/0.5V	60	350	0.30	1000	1000
KTW1008UC091□SC	G、J、K	91	50MHz/0.5V	60	350	0.30	1000	1000
KTW1008UCR10□SC	G、J、K	100	25MHz/0.5V	60	350	0.56	650	1000
KTW1008UCR11□SC	G、J、K	110	25MHz/0.5V	60	350	0.60	650	950
KTW1008UCR12□SC	G、J、K	120	25MHz/0.5V	60	350	0.63	650	950
KTW1008UCR14□SC	G、J、K	140	25MHz/0.5V	45	100	0.68	600	900
KTW1008UCR15□SC	G、J、K	150	25MHz/0.5V	45	100	0.70	580	800
KTW1008UCR16□SC	G、J、K	160	25MHz/0.5V	45	100	0.75	580	800
KTW1008UCR18□SC	G、J、K	180	25MHz/0.5V	45	100	0.77	620	640
KTW1008UCR20□SC	G、J、K	200	25MHz/0.5V	45	100	0.80	550	620
KTW1008UCR22□SC	G、J、K	220	25MHz/0.5V	45	100	0.84	500	620
KTW1008UCR24□SC	G、J、K	240	25MHz/0.5V	45	100	0.88	500	600
KTW1008UCR27□SC	G、J、K	270	25MHz/0.5V	45	100	0.91	500	600
KTW1008UCR30□SC	G、J、K	300	25MHz/0.5V	45	100	1.00	500	520
KTW1008UCR33□SC	G、J、K	330	25MHz/0.5V	45	100	1.05	450	500
KTW1008UCR36□SC	G、J、K	360	25MHz/0.5V	45	100	1.10	470	480
KTW1008UCR39□SC	G、J、K	390	25MHz/0.5V	45	100	1.12	470	480
KTW1008UCR43□SC	G、J、K	430	25MHz/0.5V	45	100	1.12	400	420
KTW1008UCR47□SC	G、J、K	470	25MHz/0.5V	45	100	1.19	470	450
KTW1008UCR50□SC	G、J、K	500	25MHz/0.5V	45	100	1.25	400	450
KTW1008UCR51□SC	G、J、K	510	25MHz/0.5V	45	100	1.30	400	430
KTW1008UCR56□SC	G、J、K	560	25MHz/0.5V	45	100	1.33	400	415
KTW1008UCR62□SC	G、J、K	620	25MHz/0.5V	45	100	1.40	400	375
KTW1008UCR66□SC	G、J、K	660	25MHz/0.5V	45	100	1.47	400	375
KTW1008UCR68□SC	G、J、K	680	25MHz/0.5V	45	100	1.47	400	375
KTW1008UCR75□SC	G、J、K	750	25MHz/0.5V	45	100	1.54	360	360
KTW1008UCR82□SC	G、J、K	820	25MHz/0.5V	45	100	1.61	400	250
KTW1008UCR91□SC	G、J、K	910	25MHz/0.5V	35	50	1.68	380	220
KTW1008UC1R0□SC	G、J、K	1000	25MHz/0.5V	35	50	1.75	370	210
KTW1008UC1R2□SC	G、J、K	1200	7.9MHz/0.5V	35	50	2.00	310	200
KTW1008UC1R5□SC	G、J、K	1500	7.9MHz/0.5V	28	50	2.30	330	180
KTW1008UC1R8□SC	G、J、K	1800	7.9MHz/0.5V	28	50	2.60	300	160
KTW1008UC2R0□SC	G、J、K	2000	7.9MHz/0.5V	20	50	2.80	280	90
KTW1008UC2R2□SC	G、J、K	2200	7.9MHz/0.5V	20	50	2.80	280	90
KTW1008UC2R7□SC	G、J、K	2700	7.9MHz/0.5V	22	25	3.20	290	80
KTW1008UC3R0□SC	G、J、K	3000	7.9MHz/0.5V	22	25	3.30	290	80
KTW1008UC3R3□SC	G、J、K	3300	7.9MHz/0.5V	22	25	3.40	290	70
KTW1008UC3R9□SC	G、J、K	3900	7.9MHz/0.5V	16	25	3.60	260	60
KTW1008UC4R3□SC	G、J、K	4300	7.9MHz/0.5V	18	25	3.80	260	60
KTW1008UC4R7□SC	J、K	4700	7.9MHz/0.5V	18	25	4.00	260	60
KTW1008UC5R6□SC	J、K	5600	7.9MHz/0.5V	18	7.9	7.60	240	55
KTW1008UC6R8□SC	J、K	6800	7.9MHz/0.5V	18	7.9	8.20	200	50
KTW1008UC7R5□SC	J、K	7500	7.9MHz/0.5V	18	7.9	8.00	180	45
KTW1008UC8R2□SC	J、K	8200	7.9MHz/0.5V	18	7.9	8.20	170	40

All specifications are subject to change without notice.

KTW1210HC Electrical Characteristics

Part Number	Tolerance	Inductance (nH) ①	Inductance Test Conditions	Q value min.	Q value Test frequency (MHz)	DCR(Ω) max. ②	Rated current (mA) ③	SRF(MHz) min.
KTW1210HC3N9□SC	K	3.9	100MHz/0.5V	30	300	0.05	1000	6000
KTW1210HC4N7□SC	J、K	4.7	100MHz/0.5V	30	300	0.065	1000	5800
KTW1210HC8N2□SC	K	8.2	100MHz/0.5V	30	300	0.07	1000	5500
KTW1210HC010□SC	G、J、K	10	100MHz/0.5V	40	300	0.08	1000	4000
KTW1210HC012□SC	G、J、K	12	100MHz/0.5V	40	300	0.08	1000	3200
KTW1210HC015□SC	J、K	15	100MHz/0.5V	40	300	0.10	1000	3200
KTW1210HC018□SC	G、J、K	18	100MHz/0.5V	50	300	0.10	1000	2800
KTW1210HC022□SC	G、J、K	22	100MHz/0.5V	50	300	0.10	1000	2000
KTW1210HC027□SC	G、J、K	27	100MHz/0.5V	50	300	0.11	1000	1800
KTW1210HC033□SC	G、J、K	33	100MHz/0.5V	55	300	0.11	1000	1800
KTW1210HC039□SC	G、J、K	39	100MHz/0.5V	55	300	0.12	1000	1800
KTW1210HC043□SC	G、J、K	43	100MHz/0.5V	55	300	0.12	1000	1500
KTW1210HC047□SC	G、J、K	47	100MHz/0.5V	55	300	0.13	1000	1500
KTW1210HC056□SC	G、J、K	56	100MHz/0.5V	55	300	0.14	1000	1450
KTW1210HC068□SC	G、J、K	68	100MHz/0.5V	55	300	0.15	900	1200
KTW1210HC082□SC	G、J、K	82	100MHz/0.5V	55	300	0.20	900	1000
KTW1210HCR10□SC	G、J、K	100	100MHz/0.5V	55	300	0.21	850	900
KTW1210HCR12□SC	G、J、K	120	100MHz/0.5V	60	300	0.21	800	800
KTW1210HCR15□SC	G、J、K	150	100MHz/0.5V	60	300	0.25	750	780
KTW1210HCR18□SC	G、J、K	180	50MHz/0.5V	60	300	0.30	700	760
KTW1210HCR20□SC	G、J、K	200	50MHz/0.5V	60	300	0.31	680	650
KTW1210HCR22□SC	G、J、K	220	50MHz/0.5V	60	300	0.32	670	650
KTW1210HCR24□SC	G、J、K	240	50MHz/0.5V	60	300	0.32	650	600
KTW1210HCR27□SC	G、J、K	270	50MHz/0.5V	55	300	0.34	630	620
KTW1210HCR30□SC	G、J、K	300	50MHz/0.5V	45	150	0.35	600	600
KTW1210HCR33□SC	G、J、K	330	50MHz/0.5V	45	150	0.38	590	600
KTW1210HCR37□SC	G、J、K	370	50MHz/0.5V	45	150	0.50	550	550
KTW1210HCR39□SC	G、J、K	390	50MHz/0.5V	45	150	0.58	530	510
KTW1210HCR43□SC	G、J、K	430	50MHz/0.5V	45	150	0.65	500	500
KTW1210HCR47□SC	G、J、K	470	50MHz/0.5V	45	150	0.80	490	500
KTW1210HCR56□SC	G、J、K	560	35MHz/0.5V	45	150	1.10	460	420
KTW1210HCR60□SC	G、J、K	600	35MHz/0.5V	45	150	1.20	450	420
KTW1210HCR62□SC	G、J、K	620	35MHz/0.5V	45	150	1.20	430	420
KTW1210HCR68□SC	G、J、K	680	35MHz/0.5V	45	150	1.20	430	400
KTW1210HCR75□SC	G、J、K	750	35MHz/0.5V	45	150	1.70	400	380
KTW1210HCR82□SC	G、J、K	820	35MHz/0.5V	45	150	1.82	400	370
KTW1210HCR88□SC	G、J、K	880	35MHz/0.5V	45	150	1.85	350	360
KTW1210HCR91□SC	G、J、K	910	35MHz/0.5V	45	150	1.85	350	360
KTW1210HC1R0□SC	G、J、K	1000	35MHz/0.5V	45	150	1.85	320	340
KTW1210HC1R2□SC	G、J、K	1200	35MHz/0.5V	35	150	1.87	300	220
KTW1210HC1R3□SC	G、J、K	1300	35MHz/0.5V	35	150	1.90	300	280
KTW1210HC1R5□SC	G、J、K	1500	7.9MHz/0.5V	30	50	1.95	310	160
KTW1210HC1R8□SC	G、J、K	1800	7.9MHz/0.5V	30	50	2.25	310	160
KTW1210HC2R2□SC	G、J、K	2200	7.9MHz/0.5V	30	50	2.41	310	110
KTW1210HC2R6□SC	G、J、K	2600	7.9MHz/0.5V	25	25	2.50	300	100
KTW1210HC2R7□SC	G、J、K	2700	7.9MHz/0.5V	25	25	2.85	300	100

All specifications are subject to change without notice.

KTW-C Series Ceramic Chip Wire Wound Inductors

KTW1210HC Electrical Characteristics

Part Number	Tolerance	Inductance (nH) ①	Inductance Test Conditions	Q value min.	Q value Test frequency (MHz)	DCR(Ω) max. ②	Rated current (mA) ③	SRF(MHz) min.
KTW1210HC3R3□SC	G、J、K	3300	7.9MHz/0.5V	20	25	3.12	300	85
KTW1210HC3R5□SC	G、J、K	3500	7.9MHz/0.5V	20	25	3.20	300	82
KTW1210HC3R9□SC	G、J、K	3900	7.9MHz/0.5V	20	25	3.60	290	80
KTW1210HC4R7□SC	J、K	4700	7.9MHz/0.5V	16	25	4.00	280	60
KTW1210HC5R6□SC	J、K	5600	7.9MHz/0.5V	20	7.9	5.00	250	60
KTW1210HC6R8□SC	J、K	6800	7.9MHz/0.5V	20	7.9	8.00	230	55
KTW1210HC7R5□SC	J、K	7500	7.9MHz/0.5V	20	7.9	8.50	200	50
KTW1210HC8R2□SC	J、K	8200	7.9MHz/0.5V	20	7.9	8.60	170	50
KTW1210HC8R6□SC	J、K	8600	7.9MHz/0.5V	20	7.9	9.00	160	40
KTW1210HC100□SC	J、K	10000	7.9MHz/0.5V	22	7.9	6.80	200	20

Note:

- ① Inductance tested using an Agilent/HP4286A or equivalent.
- ② DCR measured on a micro-ohmmeter.
- ③ Rated current: The DC current at which the temperature rise $\Delta t=40^{\circ}\text{C}$ ($T_a=20^{\circ}\text{C}$).
- ④ □ Represents the tolerance of inductance: G ($\pm 2\%$); J ($\pm 5\%$); K ($\pm 10\%$).

Dimensions(mm)

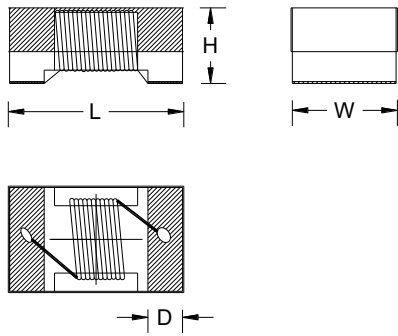

Recommended Patterns

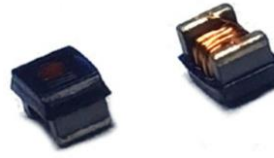
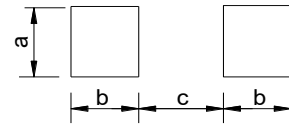

Type	L	W	H	D	a	b	c	Packaging (pcs/reel)
KTW0603UF	1.80 Max.	1.25 Max.	1.25 Max.	0.30	1.02	0.64	0.64	4000
KTW0805UF	2.30 Max.	1.70 Max.	1.52 Max.	0.50	1.78	1.02	0.76	3000
KTW1008IF	2.92 Max.	2.79 Max.	2.10 Max.	0.50	2.54	1.02	1.27	2000
KTW1210IF	3.50 Max.	2.90 Max.	2.25 Max.	0.50	2.54	1.02	1.78	2000
KTW1812IF	4.80 Max.	3.40 Max.	3.15 Max.	0.65	3.05	1.14	3.00	2000

Dimensions without tolerance are typical.

Product Identification

KTW **0603** **UF** **1N0** □ **S** **C**

① ② ③ ④ ⑤ ⑥ ⑦

- ① Wire Wound Inductor Series :
- ② Dimensions : 0603(inch)=1608(mm)=1.6x0.8mm
- ③ Material : UF Ferrite core :
- ④ Inductance : 1N0=1.0nH,010=10nH,R10=100nH,1R0=1.0μH,100=10μH,101=100uH,102=1.0mH
- ⑤ Tolerance : K=±10%,M=±20%
- ⑥ Terminal : S(Tin)
- ⑦ Packaging type : C=Tape& Reel, B=Bulk

KTW-F Series Ferrite Chip Wire Wound Inductors

KTW0603UF Electrical Characteristics

Part Number	Tolerance	Inductance (uH) ①	Inductance Test Conditions	Q value min.	Q value Test frequency (MHz)	DCR(Ω) max. ②	Rated current (mA) ③	SRF(MHz) min.
KTW0603UF047□SC	J、K	0.047	7.9MHz/0.5V	12	7.9	0.10	1000	1500
KTW0603UF072□SC	J、K	0.072	7.9MHz/0.5V	12	7.9	0.12	1000	1400
KTW0603UF082□SC	J、K	0.082	7.9MHz/0.5V	12	7.9	0.10	1000	1300
KTW0603UFR10□SC	J、K	0.10	7.9MHz/0.5V	12	7.9	0.13	1000	1150
KTW0603UFR12□SC	J、K	0.12	7.9MHz/0.5V	12	7.9	0.16	1000	1100
KTW0603UFR15□SC	J、K	0.15	7.9MHz/0.5V	12	7.9	0.15	1000	1050
KTW0603UFR18□SC	J、K	0.18	7.9MHz/0.5V	12	7.9	0.18	1000	950
KTW0603UFR22□SC	J、K	0.22	7.9MHz/0.5V	12	7.9	0.20	900	900
KTW0603UFR24□SC	J、K	0.24	7.9MHz/0.5V	12	7.9	0.28	850	800
KTW0603UFR27□SC	J、K	0.27	7.9MHz/0.5V	12	7.9	0.30	700	775
KTW0603UFR33□SC	J、K	0.33	7.9MHz/0.5V	12	7.9	0.32	600	725
KTW0603UFR39□SC	J、K	0.39	7.9MHz/0.5V	12	7.9	0.51	500	620
KTW0603UFR47□SC	J、K	0.47	7.9MHz/0.5V	12	7.9	0.62	420	540
KTW0603UFR56□SC	J、K	0.56	7.9MHz/0.5V	12	7.9	0.65	400	600
KTW0603UFR68□SC	J、K	0.68	7.9MHz/0.5V	12	7.9	1.00	380	500
KTW0603UFR78□SC	J、K	0.78	7.9MHz/0.5V	12	7.9	1.30	370	450
KTW0603UFR82□SC	J、K	0.82	7.9MHz/0.5V	12	7.9	1.30	350	500
KTW0603UF1R0□SC	J、K	1.0	7.9MHz/0.5V	12	7.9	1.50	330	400
KTW0603UF1R2□SC	J、K	1.2	7.9MHz/0.5V	12	7.9	1.70	320	380
KTW0603UF1R5□SC	J、K	1.5	7.9MHz/0.5V	12	7.9	1.90	310	300
KTW0603UF1R8□SC	J、K	1.8	7.9MHz/0.5V	12	7.9	2.20	300	180
KTW0603UF2R2□SC	J、K	2.2	7.9MHz/0.5V	12	7.9	2.30	280	180
KTW0603UF2R7□SC	J、K	2.7	7.9MHz/0.5V	12	7.9	3.10	250	150
KTW0603UF3R3□SC	J、K	3.3	7.9MHz/0.5V	12	7.9	2.90	230	150
KTW0603UF3R9□SC	J、K	3.9	7.9MHz/0.5V	12	7.9	3.20	210	120
KTW0603UF4R7□SC	J、K	4.7	7.9MHz/0.5V	12	7.9	4.0	200	100
KTW0603UF5R6□SC	J、K	5.6	7.9MHz/0.5V	12	7.9	2.6	240	32
KTW0603UF6R8□SC	J、K	6.8	7.9MHz/0.5V	12	7.9	3.9	200	31
KTW0603UF8R2□SC	J、K	8.2	7.9MHz/0.5V	12	7.9	4.2	190	26
KTW0603UF100□SC	J、K	10	2.5MHz/0.5V	10	2.5	4.8	180	25
KTW0603UF150□SC	J、K	15	2.5MHz/0.5V	10	2.5	8.5	170	23
KTW0603UF180□SC	J、K	18	2.5MHz/0.5V	10	2.5	10	160	22
KTW0603UF220□SC	J、K	22	2.5MHz/0.5V	10	2.5	12	100	10

KTW0805UF Electrical Characteristics

Part Number	Tolerance	Inductance (uH) ①	Inductance Test Conditions	Q value min.	Q value Test frequency (MHz)	DCR(Ω) max. ②	Rated current (mA) ③	SRF(MHz) min.
KTW0805UFR33□SC	J、K	0.33	25.2MHz/0.5V	15	25.2	0.40	500	500
KTW0805UFR56□SC	J、K	0.56	25.2MHz/0.5V	10	25.2	0.40	500	450
KTW0805UFR68□SC	J、K	0.68	25.2MHz/0.5V	10	25.2	0.60	500	400
KTW0805UFR82□SC	J、K	0.82	25.2MHz/0.5V	10	25.2	0.80	500	400
KTW0805UF1R0□SC	J、K	1.0	7.96MHz/0.5V	10	7.96	1.00	430	360
KTW0805UF1R2□SC	J、K	1.2	7.96MHz/0.5V	10	7.96	1.15	410	350
KTW0805UF1R5□SC	J、K	1.5	7.96MHz/0.5V	10	7.96	1.20	400	300
KTW0805UF1R8□SC	J、K	1.8	7.96MHz/0.5V	10	7.96	1.35	380	200

All specifications are subject to change without notice.

KTW-F Series Ferrite Chip Wire Wound Inductors

KTW0805UF Electrical Characteristics

Part Number	Tolerance	Inductance (uH) ①	Inductance Test Conditions	Q value min.	Q value Test frequency (MHz)	DCR (Ω) max. ②	Rated current (mA) ③	SRF(MHz) min.
KTW0805UF2R0□SC	J、K	2.0	7.96MHz/0.5V	12	7.96	1.45	350	200
KTW0805UF2R2□SC	J、K	2.2	7.96MHz/0.5V	10	7.96	1.50	350	170
KTW0805UF2R4□SC	J、K	2.4	7.96MHz/0.5V	10	7.96	1.60	330	145
KTW0805UF2R7□SC	J、K	2.7	7.96MHz/0.5V	10	7.96	1.70	320	100
KTW0805UF3R0□SC	J、K	3.0	7.96MHz/0.5V	10	7.96	1.80	300	100
KTW0805UF3R3□SC	J、K	3.3	7.96MHz/0.5V	10	7.96	1.80	300	90
KTW0805UF3R9□SC	J、K	3.9	7.96MHz/0.5V	10	7.96	1.95	280	90
KTW0805UF4R3□SC	J、K	4.3	7.96MHz/0.5V	10	7.96	2.00	270	85
KTW0805UF4R7□SC	J、K	4.7	7.96MHz/0.5V	10	7.96	2.05	250	85
KTW0805UF5R1□SC	J、K	5.1	7.96MHz/0.5V	10	7.96	2.20	240	60
KTW0805UF5R6□SC	J、K	5.6	7.96MHz/0.5V	10	7.96	2.30	240	70
KTW0805UF6R8□SC	J、K	6.8	7.96MHz/0.5V	10	7.96	2.60	220	55
KTW0805UF7R5□SC	J、K	7.5	7.96MHz/0.5V	10	7.96	2.80	210	55
KTW0805UF8R2□SC	J、K	8.2	7.96MHz/0.5V	10	7.96	3.00	180	50
KTW0805UF100□SC	J、K	10	2.52MHz/0.5V	8	2.52	3.20	150	30
KTW0805UF120□SC	J、K	12	2.52MHz/0.5V	8	2.52	3.50	110	17
KTW0805UF150□SC	J、K	15	2.52MHz/0.5V	8	2.52	4.20	100	16
KTW0805UF180□SC	J、K	18	2.52MHz/0.5V	8	2.52	4.50	95	15
KTW0805UF220□SC	J、K	22	2.52MHz/0.5V	8	2.52	6.00	80	14

KTW1008IF Electrical Characteristics

Part Number	Tolerance	Inductance (uH) ①	Inductance Test Conditions	Q value min.	Q value Test frequency (MHz)	DCR(Ω) max. ②	Rated current (mA) ③	SRF(MHz) min.
KTW1008IFR12□SC	J、K	0.12	25.2MHz/0.5V	12	25.2	0.15	800	850
KTW1008IFR39□SC	J、K	0.39	25.2MHz/0.5V	12	25.2	0.29	600	480
KTW1008IFR56□SC	J、K	0.56	25.2MHz/0.5V	12	25.2	0.42	600	330
KTW1008IFR68□SC	J、K	0.68	25.2MHz/0.5V	12	25.2	0.45	600	330
KTW1008IFR82□SC	J、K	0.82	25.2MHz/0.5V	12	25.2	0.62	600	300
KTW1008IF1R0□SC	J、K	1.0	25.2MHz/0.5V	12	25.2	0.55	580	300
KTW1008IF1R2□SC	J、K	1.2	7.96MHz/0.5V	12	7.96	0.75	550	250
KTW1008IF1R5□SC	J、K	1.5	7.96MHz/0.5V	12	7.96	0.85	400	230
KTW1008IF1R8□SC	J、K	1.8	7.96MHz/0.5V	12	7.96	0.95	320	168
KTW1008IF2R2□SC	J、K	2.2	7.96MHz/0.5V	12	7.96	1.30	315	150
KTW1008IF2R7□SC	J、K	2.7	7.96MHz/0.5V	12	7.96	1.40	300	100
KTW1008IF3R3□SC	J、K	3.3	7.96MHz/0.5V	12	7.96	1.50	280	80
KTW1008IF3R9□SC	J、K	3.9	7.96MHz/0.5V	12	7.96	1.55	250	60
KTW1008IF4R7□SC	J、K	4.7	7.96MHz/0.5V	12	7.96	1.75	210	50
KTW1008IF5R1□SC	J、K	5.1	7.96MHz/0.5V	12	7.96	1.80	200	45
KTW1008IF5R6□SC	J、K	5.6	7.96MHz/0.5V	12	7.96	1.90	190	40
KTW1008IF6R8□SC	J、K	6.8	7.96MHz/0.5V	12	7.96	2.00	175	35
KTW1008IF7R5□SC	J、K	7.5	7.96MHz/0.5V	12	7.96	2.10	170	30
KTW1008IF8R2□SC	J、K	8.2	7.96MHz/0.5V	12	7.96	2.20	160	25
KTW1008IF100□SC	J、K	10	2.52MHz/0.5V	10	2.52	2.50	155	25
KTW1008IF120□SC	J、K	12	2.52MHz/0.5V	10	2.52	2.60	145	20
KTW1008IF150□SC	J、K	15	2.52MHz/0.5V	10	2.52	3.00	130	20

All specifications are subject to change without notice.

KTW1008IF Electrical Characteristics

Part Number	Tolerance	Inductance (uH) ①	Inductance Test Conditions	Q value min.	Q value Test frequency (MHz)	DCR(Ω) max. ②	Rated current (mA) ③	SRF(MHz) min.
KTW1008IF180□SC	J、K	18	2.52MHz/0.5V	10	2.52	3.00	130	20
KTW1008IF220□SC	J、K	22	2.52MHz/0.5V	10	2.52	3.90	105	18
KTW1008IF270□SC	J、K	27	2.52MHz/0.5V	10	2.52	4.00	100	10
KTW1008IF330□SC	J、K	33	2.52MHz/0.5V	10	2.52	4.80	85	8
KTW1008IF390□SC	J、K	39	2.52MHz/0.5V	10	2.52	5.00	80	7
KTW1008IF470□SC	J、K	47	2.52MHz/0.5V	10	2.52	5.70	60	7
KTW1008IF560□SC	J、K	56	2.52MHz/0.5V	10	2.52	6.00	55	6.5
KTW1008IF680□SC	J、K	68	2.52MHz/0.5V	10	2.52	6.70	50	6.5
KTW1008IF820□SC	J、K	82	2.52MHz/0.5V	10	2.52	7.50	45	6.5
KTW1008IF101□SC	J、K	100	0.796MHz/0.5V	8	0.796	11.0	40	4.5
KTW1008IF121□SC	J、K	120	0.796MHz/0.5V	8	0.796	13.0	30	3
KTW1008IF151□SC	J、K	150	0.796MHz/0.5V	8	0.796	15.0	25	3
KTW1008IF221□SC	K	220	0.796MHz/0.5V	8	0.796	18.0	20	2.5

KTW1210IF Electrical Characteristics

Part Number	Tolerance	Inductance (uH) ①	Inductance Test Conditions	Q value min.	Q value Test frequency (MHz)	DCR (Ω) max.②.	Rated current (mA) ③	SRF(MHz) min.
KTW1210IFR12□SC	J、K	0.12	25.2MHz/0.5V	20	25.2	0.20	450	850
KTW1210IFR27□SC	J、K	0.27	25.2MHz/0.5V	20	25.2	0.20	450	700
KTW1210IFR33□SC	J、K	0.33	25.2MHz/0.5V	20	25.2	0.30	450	520
KTW1210IFR47□SC	J、K	0.47	25.2MHz/0.5V	20	25.2	0.30	450	480
KTW1210IFR82□SC	J、K	0.82	25.2MHz/0.5V	20	25.2	0.30	450	350
KTW1210IF1R0□SC	J、K	1.0	7.96MHz/0.5V	12	7.96	0.30	450	220
KTW1210IF1R2□SC	J、K	1.2	7.96MHz/0.5V	12	7.96	0.30	450	210
KTW1210IF1R5□SC	J、K	1.5	7.96MHz/0.5V	12	7.96	0.40	450	200
KTW1210IF1R8□SC	J、K	1.8	7.96MHz/0.5V	12	7.96	0.50	450	195
KTW1210IF2R2□SC	J、K	2.2	7.96MHz/0.5V	12	7.96	0.60	450	175
KTW1210IF2R7□SC	J、K	2.7	7.96MHz/0.5V	12	7.96	0.70	420	120
KTW1210IF3R3□SC	J、K	3.3	7.96MHz/0.5V	12	7.96	1.10	380	80
KTW1210IF3R9□SC	J、K	3.9	7.96MHz/0.5V	12	7.96	1.20	360	75
KTW1210IF4R3□SC	J、K	4.3	7.96MHz/0.5V	12	7.96	1.20	360	70
KTW1210IF4R7□SC	J、K	4.7	7.96MHz/0.5V	12	7.96	1.30	350	60
KTW1210IF5R6□SC	J、K	5.6	7.96MHz/0.5V	12	7.96	2.00	320	50
KTW1210IF6R8□SC	J、K	6.8	7.96MHz/0.5V	12	7.96	1.50	310	35
KTW1210IF8R2□SC	J、K	8.2	7.96MHz/0.5V	12	7.96	1.60	305	35
KTW1210IF100□SC	J、K	10	2.52MHz/0.5V	10	2.52	1.00	300	30
KTW1210IF120□SC	J、K	12	2.52MHz/0.5V	10	2.52	1.20	265	25
KTW1210IF130□SC	J、K	13	2.52MHz/0.5V	10	2.52	1.20	250	22
KTW1210IF150□SC	J、K	15	2.52MHz/0.5V	10	2.52	2.00	225	22
KTW1210IF180□SC	J、K	18	2.52MHz/0.5V	10	2.52	2.10	210	22
KTW1210IF200□SC	J、K	20	2.52MHz/0.5V	10	2.52	2.40	200	20
KTW1210IF220□SC	J、K	22	2.52MHz/0.5V	10	2.52	2.40	200	20
KTW1210IF270□SC	J、K	27	2.52MHz/0.5V	10	2.52	2.70	180	18
KTW1210IF330□SC	J、K	33	2.52MHz/0.5V	10	2.52	2.90	160	15
KTW1210IF350□SC	J、K	35	2.52MHz/0.5V	10	2.52	4.20	145	16

All specifications are subject to change without notice.

KTW-F Series Ferrite Chip Wire Wound Inductors

KTW1210IF Electrical Characteristics

Part Number	Tolerance	Inductance (uH) ①	Inductance Test Conditions	Q value min.	Q value Test frequency (MHz)	DCR(Ω) max. ②	Rated current (mA) ③	SRF(MHz) min.
KTW1210IF390□SC	J、K	39	2.52MHz/0.5V	10	2.52	4.70	150	16
KTW1210IF470□SC	J、K	47	2.52MHz/0.5V	10	2.52	5.20	140	10
KTW1210IF560□SC	J、K	56	2.52MHz/0.5V	10	2.52	5.60	125	8.0
KTW1210IF680□SC	J、K	68	2.52MHz/0.5V	10	2.52	4.70	110	5.0
KTW1210IF750□SC	J、K	75	2.52MHz/0.5V	10	2.52	5.50	100	5.0
KTW1210IF820□SC	J、K	82	2.52MHz/0.5V	10	2.52	5.60	100	5.0
KTW1210IF880□SC	J、K	88	2.52MHz/0.5V	10	2.52	6.00	95	5.0
KTW1210IF101□SC	J、K	100	0.796MHz/0.5V	8	0.796	6.80	95	5.0
KTW1210IF121□SC	J、K	120	0.796MHz/0.5V	8	0.796	7.90	85	4.0
KTW1210IF151□SC	J、K	150	0.796MHz/0.5V	8	0.796	9.00	80	4.0
KTW1210IF161□SC	J、K	160	0.796MHz/0.5V	8	0.796	9.10	75	3.0
KTW1210IF181□SC	J、K	180	0.796MHz/0.5V	8	0.796	14.5	70	3.0
KTW1210IF201□SC	J、K	200	0.796MHz/0.5V	8	0.796	16.5	65	2.5
KTW1210IF221□SC	J、K	220	0.796MHz/0.5V	8	0.796	16.5	65	2.6
KTW1210IF271□SC	K	270	0.796MHz/0.5V	8	0.796	18.0	60	2.5
KTW1210IF301□SC	K	300	0.796MHz/0.5V	8	0.796	20.0	55	2.4
KTW1210IF331□SC	K	330	0.796MHz/0.5V	8	0.796	19.0	55	2.3
KTW1210IF391□SC	K	390	0.796MHz/0.5V	8	0.796	21.5	45	2.2
KTW1210IF471□SC	K	470	0.796MHz/0.5V	8	0.796	22.5	40	2.0
KTW1210IF561□SC	K	560	0.796MHz/0.5V	8	0.796	28.0	30	1.5

KTW1812IF Electrical Characteristics

Part Number	Tolerance	Inductance (uH) ①	Inductance Test Conditions	Q value min.	Q value Test frequency (MHz)	DCR(Ω) max. ②	Rated current (mA) ③	SRF(MHz) min.
KTW1812IFR33□SC	J、K	0.33	25.2MHz/0.5V	10	25.2	0.13	1000	380
KTW1812IFR56□SC	J、K	0.56	25.2MHz/0.5V	10	25.2	0.15	1000	300
KTW1812IFR82□SC	J、K	0.82	25.2MHz/0.5V	10	25.2	0.20	1000	250
KTW1812IF1R0□SC	J、K	1.0	7.96MHz/0.5V	15	7.96	0.22	1000	200
KTW1812IF1R2□SC	J、K	1.2	7.96MHz/0.5V	15	7.96	0.35	1000	200
KTW1812IF1R5□SC	J、K	1.5	7.96MHz/0.5V	15	7.96	0.32	1000	180
KTW1812IF1R8□SC	J、K	1.8	7.96MHz/0.5V	15	7.96	0.35	950	160
KTW1812IF2R2□SC	J、K	2.2	7.96MHz/0.5V	15	7.96	0.37	900	150
KTW1812IF2R7□SC	J、K	2.7	7.96MHz/0.5V	15	7.96	0.37	850	145
KTW1812IF3R3□SC	J、K	3.3	7.96MHz/0.5V	15	7.96	0.48	800	140
KTW1812IF3R9□SC	J、K	3.9	7.96MHz/0.5V	15	7.96	0.60	750	135
KTW1812IF4R7□SC	J、K	4.7	7.96MHz/0.5V	15	7.96	1.00	700	120
KTW1812IF5R6□SC	J、K	5.6	7.96MHz/0.5V	15	7.96	0.55	650	110
KTW1812IF6R8□SC	J、K	6.8	7.96MHz/0.5V	15	7.96	0.80	600	80
KTW1812IF8R2□SC	J、K	8.2	7.96MHz/0.5V	10	7.96	0.85	600	70
KTW1812IF100□SC	J、K	10	2.52MHz/0.5V	10	2.52	1.00	550	65
KTW1812IF120□SC	J、K	12	2.52MHz/0.5V	10	2.52	1.10	550	55
KTW1812IF150□SC	J、K	15	2.52MHz/0.5V	10	2.52	1.20	500	35
KTW1812IF180□SC	J、K	18	2.52MHz/0.5V	10	2.52	1.20	500	29
KTW1812IF220□SC	J、K	22	2.52MHz/0.5V	10	2.52	1.30	450	20
KTW1812IF270□SC	J、K	27	2.52MHz/0.5V	10	2.52	1.50	400	20

All specifications are subject to change without notice.

KTW1812IF Electrical Characteristics

Part Number	Tolerance	Inductance (uH) ①	Inductance Test Conditions	Q value min.	Q value Test frequency (MHz)	DCR (Ω) max. ②	Rated current (mA) ③	SRF(MHz) min.
KTW1812IF330□SC	J、K	33	2.52MHz/0.5V	10	2.52	1.70	350	18
KTW1812IF390□SC	J、K	39	2.52MHz/0.5V	10	2.52	1.80	350	14
KTW1812IF470□SC	J、K	47	2.52MHz/0.5V	10	2.52	2.00	300	10
KTW1812IF560□SC	J、K	56	2.52MHz/0.5V	10	2.52	2.20	290	10
KTW1812IF680□SC	J、K	68	2.52MHz/0.5V	10	2.52	2.40	260	5.4
KTW1812IF820□SC	J、K	82	2.52MHz/0.5V	10	2.52	2.80	240	5.2
KTW1812IF101□SC	J、K	100	0.796MHz/0.5V	10	0.796	3.00	220	4.0
KTW1812IF121□SC	J、K	120	0.796MHz/0.5V	10	0.796	3.30	220	3.3
KTW1812IF151□SC	J、K	150	0.796MHz/0.5V	10	0.796	3.70	200	3.0
KTW1812IF181□SC	J、K	180	0.796MHz/0.5V	10	0.796	4.50	200	3.0
KTW1812IF221□SC	J、K	220	0.796MHz/0.5V	10	0.796	8.00	170	2.5
KTW1812IF271□SC	J、K	270	0.796MHz/0.5V	10	0.796	8.50	160	2.2
KTW1812IF331□SC	K	330	0.796MHz/0.5V	10	0.796	9.00	150	2.0
KTW1812IF391□SC	K	390	0.796MHz/0.5V	10	0.796	9.50	130	1.8
KTW1812IF471□SC	K	470	0.796MHz/0.5V	8	0.796	10.4	120	1.6
KTW1812IF561□SC	K	560	0.796MHz/0.5V	8	0.796	12.5	110	1.5
KTW1812IF681□SC	K	680	0.796MHz/0.5V	8	0.796	14.0	100	1.5
KTW1812IF751□SC	K	750	0.796MHz/0.5V	8	0.796	14.5	95	1.5
KTW1812IF821□SC	K	820	0.796MHz/0.5V	8	0.796	15.0	95	1.5
KTW1812IF102□SC	K	1000	0.252MHz/0.5V	6	0.252	16.5	90	1.4

Note:

- ① Inductance tested using an Agilent/HP4286A or equivalent.
 - ② DCR measured on a micro-ohmmeter.
 - ③ Rated current: The DC current at which the temperature rise $\Delta t=40^{\circ}\text{C}$ ($T_a=20^{\circ}\text{C}$).
- Represents the tolerance of inductance: K=±10%,M=±20%

Product outline

- Ferrite material chip inductors, miniature size, suitable for SMT process.
- Terminal electrode structure is used to restrain the parasitic component effect caused by lead.
- Low DC resistance, high current and high inductance value.
- For audio/Video equipment, telecom and Blue Tooth and earphones (KTW-TH, TU, TQ 蓝牙、耳机应用) applications.



Dimensions(mm)

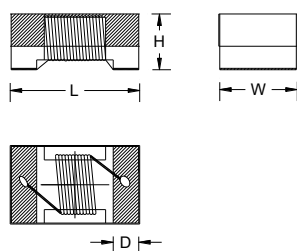

Recommended Patterns

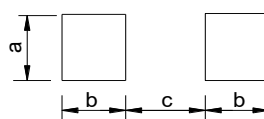

Type	L	W	H	D	a	b	c	Packaging (pcs/reel)
KTW0603TU	1.80 Max	1.25 Max	1.20 Max	0.35	1.02	0.64	0.64	4000
KTW0603TH	1.80 Max	1.25 Max	1.20 Max	0.35	1.02	0.64	0.64	4000
KTW0603TQ	1.80 Max	1.25 Max	1.20 Max	0.35	1.02	0.64	0.64	4000
KTW0805TU	2.40 Max	1.73 Max	1.52Max	0.50	1.78	1.02	0.76	2000
KTW0805TH	2.40 Max	1.73 Max	1.52Max.	0.50	1.78	1.02	0.76	2000
KTW0805TQ	2.40 Max	1.73 Max	1.52Max	0.50	1.78	1.02	0.76	2000

Dimensions without tolerance are typical.

Product Identification

KTW 0603 TU 1R0 □ S C - M

① ② ③ ④ ⑤ ⑥ ⑦ ⑧

- ① Wire Wound Inductor Series;
- ② Dimensions: 0603(inch)=1608(mm)=1.6x0.8mm
- ③ **TU**:UV Coating, **TH**:Magnetic Powder Epoxy Half Coating(半封),**TQ**: Magnetic Powder Epoxy Overall Coating(全封).
- ④ Inductance Value: 1R0=1.0uH,100=10uH,101=100uH
- ⑤ Tolerance: K=±10%; M=±20%
- ⑥ Terminal Material: S(Tin)
- ⑦ Packaging type: C=Tape& Reel, B=BULK
- ⑧ M:Colour Marking

KTW0603TU Electrical Characteristics

Tolerance:K±10%, M±20%

Part Number	Inductance uH ①	Q typ.①	Test Freq.	DCR (Ω) MAX.②	Isat-A Typ. ③	Irms-A Typ. ④	SRF-MHz Typ.	Colouring
KTW0603TU-1R0□SC-N	1.0	16	7.9MHz	0.41	0.86	0.70	250	N/A
KTW0603TU-1R5□SC-M	1.5	16	7.9MHz	0.52	0.70	0.60	160	Brown
KTW0603TU-1R8□SC-M	1.8	16	7.9MHz	0.56	0.65	0.58	121	Red
KTW0603TU-2R2□SC-M	2.2	16	7.9MHz	0.72	0.60	0.58	103	Orange
KTW0603TU-2R7□SC-M	2.7	16	7.9MHz	0.81	0.54	0.50	72	Yellow
KTW0603TU-3R3□SC-M	3.3	16	7.9MHz	0.91	0.48	0.50	66	Green
KTW0603TU-3R9□SC-M	3.9	16	7.9MHz	1.08	0.45	0.46	61	Blue
KTW0603TU-4R7□SC-M	4.7	16	7.9MHz	0.97	0.40	0.42	51	Violet
KTW0603TU-5R6□SC-M	5.6	16	7.9MHz	1.43	0.36	0.38	47	Gray
KTW0603TU-6R8□SC-M	6.8	16	7.9MHz	1.95	0.33	0.34	43	White
KTW0603TU-8R2□SC-N	8.2	16	7.9MHz	2.18	0.30	0.30	40	\
KTW0603TU-100□SC-M	10	14	2.5MHz	2.40	0.28	0.28	36	Brown
KTW0603TU-120□SC-M	12	14	2.5MHz	2.96	0.26	0.26	32	Red
KTW0603TU-150□SC-M	15	14	2.5MHz	3.38	0.24	0.22	29	Orange
KTW0603TU-180□SC-M	18	14	2.5MHz	3.75	0.22	0.22	28	Yellow
KTW0603TU-220□SC-M	22	14	2.5MHz	4.69	0.20	0.20	24	Green
KTW0603TU-270□SC-M	27	14	2.5MHz	6.76	0.18	0.14	20	Blue
KTW0603TU-330□SC-M	33	14	2.5MHz	8.58	0.16	0.12	15	Violet
KTW0603TU-470□SC-N	47	14	2.5MHz	12.0	0.13	0.10	5	\

KTW0603TH Electrical Characteristics

Part Number	Inductance uH ①	Q typ.①	Test Freq.	DCR± 30%(Ω)②	Isat-A Typ. ③	Irms-A Typ. ④	SRF-MHz Typ.
KTW0603TH-1R0MSC	1.0	10	1MHz	0.14	0.8	0.9	350
KTW0603TH-2R2MSC	2.2	10	1MHz	0.30	0.58	0.6	90
KTW0603TH-4R7MSC	4.7	10	1MHz	0.45	0.45	0.5	57
KTW0603TH-6R8MSC	6.8	9	1MHz	0.65	0.41	0.5	25
KTW0603TH-100MSC	10	9	1MHz	1.0	0.27	0.38	25
KTW0603TH-150MSC	15	9	1MHz	1.40	0.22	0.35	25
KTW0603TH-220MSC	22	9	1MHz	2.45	0.18	0.27	20

KTW0603TQ Electrical Characteristics

Part Number	Inductance uH ①	Q typ.①	Test Freq.	DCR (Ω) ±30%.②	Isat-A Typ. ③	Irms-A Typ. ④	SRF-MHz Typ.
KTW0603TQ-1R0MSC	1.0	10	1MHz	0.20	1.1	0.72	350
KTW0603TQ-1R5MSC	1.5	10	1MHz	0.38	0.65	0.52	300
KTW0603TQ-2R2MSC	2.2	10	1MHz	0.45	0.68	0.48	250
KTW0603TQ-4R7MSC	4.7	10	1MHz	0.70	0.45	0.4	100
KTW0603TQ-6R8MSC	6.8	9	1MHz	1.25	0.36	0.3	50
KTW0603TQ-100MSC	10	9	1MHz	1.5	0.27	0.38	25
KTW0603TQ-150MSC	15	9	1MHz	2.0	0.27	0.23	25
KTW0603TQ-220MSC	22	9	1MHz	3.9	0.22	0.16	10

All specifications are subject to change without notice.

KTW-T Series Ferrite Chip Wire Wound Inductors

KTW0805TU Electrical Characteristics

Tolerance:K±10%, M±20%

Part Number ^⑤	Inductance uH ^①	Q typ. ^①	Test Freq.	DCR (Ω) MAX. ^②	Irms-A Typ. ^④	SRF-MHz Typ.	Color
KTW0805TU-R68□SC-M	0.68	14	7.9 MHz	0.19	1.20	765	Gray
KTW0805TU-1R0□SC-N	1.0	14	7.9 MHz	0.17	1.10	208	/
KTW0805TU-1R2□SC-M	1.2	14	7.9 MHz	0.17	0.96	208	Red
KTW0805TU-1R5□SC-M	1.5	14	7.9 MHz	0.22	0.88	130	Brown
KTW0805TU-1R8□SC-M	1.8	14	7.9 MHz	0.26	0.86	112	Orange
KTW0805TU-2R2□SC-M	2.2	12	7.9 MHz	0.31	0.74	80	Red
KTW0805TU-3R3□SC-M	3.3	12	7.9 MHz	0.36	0.62	50	Orange
KTW0805TU-4R7□SC-M	4.7	14	7.9 MHz	0.56	0.52	51	Yellow
KTW0805TU-5R6□SC-M	5.6	12	7.9 MHz	0.65	0.48	42	Blue
KTW0805TU-6R8□SC-M	6.8	14	7.9 MHz	0.88	0.42	35	Green
KTW0805TU-8R2□SC-M	8.2	13	7.9 MHz	0.94	0.40	33	Purple
KTW0805TU-100□SC-M	10	14	2.5 MHz	1.17	0.30	25	Blue
KTW0805TU-120□SC-M	12	14	2.5 MHz	1.50	0.29	30	Gray
KTW0805TU-150□SC-M	15	15	2.5 MHz	1.82	0.28	28	Purple
KTW0805TU-180□SC-M	18	15	2.5 MHz	2.01	0.26	27	White
KTW0805TU-220□SC-M	22	15	2.5 MHz	2.29	0.24	20	Gray
KTW0805TU-470□SC-N	47	14	2.5 MHz	4.42	0.16	15	/
KTW0805TU-560□SC-M	56	14	2.5 MHz	5.75	0.15	10	Yellow
KTW0805TU-680□SC-M	68	14	2.5 MHz	5.79	0.14	10	Brown
KTW0805TU-820□SC-M	82	14	2.5 MHz	9.75	0.10	10	Orange
KTW0805TU-101□SC-M	100	10	1.0 MHz	9.75	0.10	9	Red

KTW0805TH Electrical Characteristics

Part Number ^⑤	Inductance uH ^①	Q typ. ^①	Test Freq.	DCR (Ω) ±30%. ^②	Isat-A Typ. ^③	Irms-A Typ. ^④	SRF-MHz Typ.
KTW0805TH-1R0MSC	1.0	12	1MHz	0.14	1.1	1.2	250
KTW0805TH-2R2MSC	2.2	12	1MHz	0.18	0.75	0.90	100
KTW0805TH-4R7MSC	4.7	12	1MHz	0.32	0.55	0.55	50
KTW0805TH-8R2MSC	8.2	12	1MHz	0.50	0.45	0.46	35
KTW0805TH-100MSC	10	12	1MHz	0.55	0.42	0.45	35

KTW0805TQ Electrical Characteristics

Part Number ^⑤	Inductance uH ^①	Q typ. ^①	Test Freq.	DCR (Ω) ±30%. ^②	Isat-A ^③ Typ.	Irms-A Typ. ^④	SRF-MHz Typ.
KTW0805TQ-1R0MSC	1.0	10	1MHz	0.12	1.2	1.0	550
KTW0805TQ-1R5MSC	1.5	10	1MHz	0.13	0.9	0.9	450
KTW0805TQ-2R2MSC	2.2	10	1MHz	0.18	0.78	0.75	400
KTW0805TQ-4R7MSC	4.7	10	1MHz	0.33	0.51	0.47	150
KTW0805TQ-6R8MSC	6.8	10	1MHz	0.35	0.47	0.45	50
KTW0805TQ-100MSC	10	10	1MHz	0.53	0.41	0.45	35
KTW0805TQ-150MSC	15	10	1MHz	0.65	0.27	0.35	25
KTW0805TQ-220MSC	22	9	1MHz	0.95	0.27	0.3	10

① Inductance L and Q tested using an E4991A or equivalent.

② DCR measured on a micro-ohmmeter.

③ Isat: The DC current at which the inductance decreases by 30% from the initial value..

④ Irms: The DC current at which the temperature rise $\Delta t=40^{\circ}\text{C}$ ($T_a=20^{\circ}\text{C}$).

All specifications are subject to change without notice.

Product outline

- Ferrite material multilayer chip inductors, miniature size, suitable for SMT process.
- No cross coupling due to magnetic shielded structures.
- Higher DC bias characteristics and Low DC resistance due to trench technology.



Dimensions(mm)

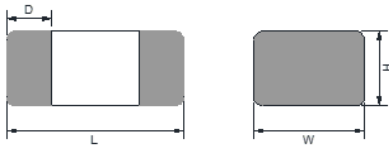

Recommended Patterns

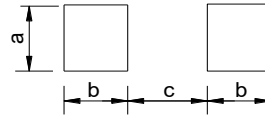

Type	L	W	H	D	a	b	c	Packaging (pcs/reel)
160809	1.6±0.2	0.8±0.2	1.1 max	0.30±0.2	0.6~0.8	0.6~0.8	0.6~0.8	4000
201210	2.0±0.2	1.2±0.2	1.0 max	0.5±0.3	0.9~1.6	0.8~1.2	0.8~1.2	4000
201212	2.0±0.2	1.2±0.2	1.2±0.2	0.5±0.3	0.9~1.6	0.8~1.2	0.8~1.2	3000
201610	2.0±0.2	1.6±0.2	1.0 max	0.5±0.3	1.2~2.0	0.8~1.2	0.8~1.2	3000
201612	2.0±0.2	1.6±0.2	1.2 max	0.5±0.3	1.2~2.0	0.8~1.2	0.8~1.2	3000
252010	2.5±0.2	2.0±0.2	1.0 max	0.5±0.3	1.8~2.2	0.6~1.0	1.0~1.4	3000
252012	2.5±0.2	2.0±0.2	1.2 max	0.5±0.3	1.8~2.2	0.6~1.0	1.0~1.4	3000

Product Identification

HPL 201209 G 2R2 M T S
 ① ② ③ ④ ⑤ ⑥ ⑦

- ① Higher DC bias Current Multilayer Inductor Series: HPL
- ② Dimensions: 0603(inch)=1608(mm)=1.6x0.8mm
- ③ G: Internal Code.
- ④ Inductance Value: R47=0.47uH, 4R7=4.7uH, 100=10uH
- ⑤ Tolerance: K=±10%, M=±20%, N=±30%
- ⑥ Packaging: T=TAPING&REEL
- ⑦ Characteristic level

HPL160809G Electrical Characteristics

Part Number	Inductance (uH) ①	DCR max. (Ω) ②	Isat-max. (A) ③	Isat-Typ. (A) ③	Irms-max (A) ④	SRF-min. MHz
HPL160809G-R47MTS	0.47	0.19	1.00	1.20	1.10	180
HPL160809G-R68MTS	0.68	0.23	0.95	1.10	1.15	160
HPL160809G-1R0MTS	1.0	0.25	0.65	0.80	1.00	125
HPL160809G-2R2MTS	2.2	0.38	0.25	0.30	0.85	80
HPL160809G-3R3MTS	3.3	0.50	0.13	0.15	0.70	80
HPL160809G-4R7MTS	4.7	0.50	0.07	0.08	0.70	65
HPL160809G-6R8MTS	6.8	0.70	0.13	0.15	0.50	45
HPL160809G-100MTS	10	0.47	0.06	0.08	0.50	35

HPL201210G Electrical Characteristics

Part Number	Inductance (uH) ①	DCR max. (Ω) ②	Isat-max. (A) ③	Isat-Typ. (A) ③	Irms-max (A) ④	SRF-min. MHz
HPL201210G-R47MTS	0.47	0.10	1.00	1.20	1.50	100
HPL201210G-1R0MTS	1	0.14	0.95	1.15	1.30	60
HPL201210G-2R2MTS	2.2	0.25	0.42	0.50	0.90	40
HPL201210G-3R3MTS	3.3	0.25	0.28	0.35	0.90	30
HPL201210G-4R7MTS	4.7	0.31	0.23	0.28	0.80	30
HPL201210G-4R7MTH	4.7	0.22	0.23	0.28	1.20	30

HPL201212G Electrical Characteristics

Part Number	Inductance (uH) ①	DCR max. (Ω) ②	Isat-max. (A) ③	Isat-Typ. (A) ③	Irms-max (A) ④	SRF-min. MHz
HPL201212G-2R2MTS	2.2	0.44	0.60	0.80	0.80	35
HPL201212G-3R3MTS	3.3	0.50	0.57	0.63	0.75	25
HPL201212G-4R7MTS	4.7	0.50	0.54	0.63	0.75	20
HPL201212G-6R8MTS	6.8	0.38	0.21	0.25	1.00	45
HPL201212G-100MTS	10	0.38	0.11	0.13	1.00	35
HPL201212G-100MTH	10	0.70	0.20	0.23	0.20	20

① Inductance tested at 1MHz/ 0.05 Vrms using an Agilent/HP 4192A or equivalent.

② DCR measured on a micro-ohmmeter.

③ Isat: The DC current at which the inductance decreases by 30% of it's initial value.

④ Irms: The DC current at which $\Delta t=40^{\circ}\text{C}$.

HPL201610G Electrical Characteristics

Part Number	Inductance (uH) ①	DCR max. (Ω) ②	Isat-max. (A) ③	Isat-Typ. (A) ③	Irms-max (A) ④	SRF-min. MHz
HPL201610G-R47MTS	0.47	0.1	1.35	1.6	1.5	100
HPL201610G-1R0MTS	1.0	0.11	1.0	1.2	1.4	70
HPL201610G-2R2MTS	2.2	0.14	0.42	0.5	1.2	50
HPL201610G-3R3MTS	3.3	0.15	0.27	0.33	1.2	40
HPL201610G-4R7MTS	4.7	0.18	0.18	0.22	1.1	30

HPL201612G Electrical Characteristics

Part Number	Inductance (uH) ①	DCR max. (Ω) ②	Isat-max. (A) ③	Isat-Typ. (A) ③	Irms-max (A) ④	SRF-min. MHz
HPL201612G-6R8MTS	6.8	0.21	0.18	0.22	1.2	40
HPL201612G-100MTS	10	0.31	0.17	0.20	1.1	35

HPL252010G Electrical Characteristics

Part Number	Inductance (uH) ①	DCR max. (Ω) ②	Isat-max. (A) ③	Isat-Typ. (A) ③	Irms-max (A) ④	SRF-min. MHz
HPL252010G-R47MTS	0.47	0.05	1.3	1.5	1.8	105
HPL252010G-1R0MTS	1.0	0.08	1.15	1.4	1.6	70
HPL252010G-2R2MTS	2.2	0.1	0.7	0.85	1.3	55
HPL252010G-3R3MTS	3.3	0.13	0.38	0.45	1.2	30
HPL252010G-4R7MTS	4.7	0.14	0.27	0.32	1.1	25
HPL252010G-6R8MTS	6.8	0.56	0.3	0.35	0.75	30
HPL252010G-100MTS	10	0.63	0.21	0.25	0.7	25

HPL252012G Electrical Characteristics

Part Number	Inductance (uH) ①	DCR max. (Ω) ②	Isat-max. (A) ③	Isat-Typ. (A) ③	Irms-max (A) ④	SRF-min. MHz
HPL252012G-1R0MTS	1.0	0.11	1.75	2.1	2.1	85
HPL252012G-2R2MTS	2.2	0.31	1.35	1.6	1.1	50
HPL252012G-3R3MTS	3.3	0.31	1.05	1.25	1.1	50
HPL252012G-4R7MTS	4.7	0.5	0.68	0.8	0.9	40
HPL252012G-6R8MTS	6.8	0.63	0.63	0.75	0.8	30
HPL252012G-100MTS	10	0.63	0.42	0.5	0.8	25

① Inductance tested at 1MHz, 0.05 Vrms using an Agilent/HP 4192A or equivalent.

② DCR measured on a micro-ohmmeter.

③ Isat: The DC current at which the inductance decreases by 30% of it's initial value.

④ Irms: The DC current at which $\Delta t=40^{\circ}\text{C}$.

Product outline

- Ferrite material multilayer chip inductors, miniature size, suitable for SMT process.
- No cross coupling due to magnetic shielded structures.



Dimensions(mm)

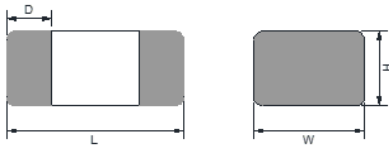

Recommended Patterns

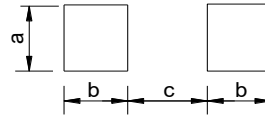

Type	L	W	H	D	a	b	c	Packaging (pcs/reel)
1608	1.6±0.2	0.8±0.2	0.8±0.2	0.3±0.2	0.6~1.5	0.2~1.0	0.2~1.0	4000
2012	2.0±0.2	1.2±0.2	0.9±0.2	0.5±0.3	0.9~1.6	0.8~1.2	0.8~1.2	4000
2016	2.0±0.2	1.6±0.2	0.9±0.2	0.5±0.3	0.9~1.6	0.8~1.2	0.8~1.2	4000
2520	2.5±0.2	2.0±0.2	1.0±0.2	0.5±0.3	1.8~2.5	0.8~1.5	0.8~1.5	3000
3216	3.2±0.2	1.6±0.2	0.90±0.2	0.5±0.3	1.8±0.2	0.8±0.2	2.0±0.2	4000

Product Identification

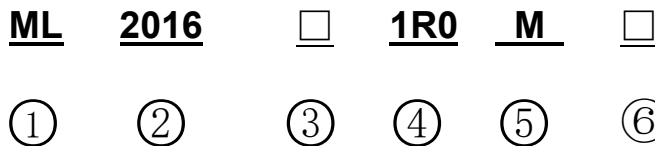

- ① Multilayer Inductor
- ② Dimensions: 2016=2.0x1.6mm
- ③ Internal control code
- ④ Inductance Value: R47=0.47uH, 4R7=4.7uH, 100=10uH
- ⑤ Tolerance: K=±10%, M=±20%, N=±30%
- ⑥ Characteristic level

ML1608H-B Electrical Characteristics

Part Number	Inductance uH	Tolerance	DCR max. (mΩ)	I _{rms} -A max.	SRF MHz Min.
ML1608HR47MB	0.47	±20%	100±30%	1.05	100
ML1608HR56MB	0.56	±20%	120±30%	1.05	100
ML1608H1R0MB	1.0	±20%	200±30%	0.9	98
ML1608H1R8MB	1.8	±20%	240±30%	0.75	95
ML1608H2R2MB	2.2	±20%	240±30%	0.75	95
ML1608H4R7MB	4.7	±20%	500±30%	0.7	65

ML2012H-A Electrical Characteristics

Part Number	Inductance uH	Tolerance	DCR max. (mΩ)	I _{rms} -A max.	SRF MHz Min.
ML2012H1R0MA	1.0	±20%	140±25%	0.3	75
ML2012H2R2MA	2.2	±20%	224±25%	0.22	50
ML2012H3R3MA	3.3	±20%	240±25%	0.2	35
ML2012H4R7MA	4.7	±20%	300±25%	0.18	25

ML2012H-B Electrical Characteristics

Part Number	Inductance uH	Tolerance	DCR max. (mΩ)	I _{rms} -A max.	SRF MHz Min.
ML2012H1R0MB	1.0	±20%	110±25%	1.15	75
ML2012H2R2MB	2.2	±20%	200±25%	0.95	50
ML2012H3R3MB	3.3	±20%	220±25%	0.8	35
ML2012H4R7MB	4.7	±20%	300±25%	0.75	25
ML2012H6R8MB	6.8	±20%	300±25%	0.6	25

ML2016H-B Electrical Characteristics

Part Number	Inductance uH	Tolerance	DCR max. (mΩ)	I _{rms} -A max.	SRF MHz Min.
ML2016H1R0MB	1.0	±20%	100±25%	1.4	70
ML2016H2R2MB	2.2	±20%	155±25%	1.2	50
ML2016H3R3MB	3.3	±20%	200±25%	1.2	40
ML2016H4R7MB	4.7	±20%	255±25%	1.1	30

- ④ Inductance :4284A. or equivalent at 1MHz/0.05V.
 ⑤ DCR: YOKOGAWA TYPE7561, or equivalent.
 ⑥ I_{rms}: based on temperature rise 40°C (Ta=20°C) .

ML2520H-A Electrical Characteristics

Part Number	Inductance uH	Tolerance	DCR max. (mΩ)	Isat-A max.	SRF MHz Min.
ML2520H1R0MA	1.0	±20%	80±25%	0.4	70
ML2520H2R2MA	2.2	±20%	120±25%	0.3	55
ML2520H3R3MA	3.3	±20%	144±25%	0.26	30
ML2520H4R7MA	4.7	±20%	180±25%	0.24	25

- ① Inductance :4284A. or equivalent at 1MHz/0.05V.
 ② DCR: YOKOGAWA TYPE7561, or equivalent.
 ③ Isat: based on the inductance drop from the initial value to be 50%.(4991B, test fixture 16200B+16192A, DC source 2400/2410).

ML2520H-B Electrical Characteristics

Part Number	Inductance uH	Tolerance	DCR max. (mΩ)	Irms-A max.	SRF MHz Min.
ML2520H1R0MB	1.0	±20%	60±25%	1.6	70
ML2520H2R2MB	2.2	±20%	100±25%	1.3	55
ML2520H3R3MB	3.3	±20%	140±25%	1.2	30
ML2520H4R7MB	4.7	±20%	180±25%	1.1	25
ML2520H6R8MB	6.8	±20%	220±25%	1.0	25

- ① Inductance :4284A. or equivalent at 1MHz/0.05V.
 ② DCR: YOKOGAWA TYPE7561, or equivalent.
 ③ Irms: based on temperature rise 40℃ (Ta=20℃) .

ML3216P Electrical Characteristics

Part Number	Inductance (uH)	Tolerance (%)	DCR max. (Ω)	Freq./voltage (MHz/mV)	Rated Current(mA)max	SRF min. (MHz)
ML3216P47NMT	0.047	±20	0.15	1MHz/50mV	450	320
ML3216P56NMT	0.056	±20	0.15	1MHz/50mV	450	320
ML3216P68NMT	0.068	±20	0.20	1MHz/50mV	450	280
ML3216P82NMT	0.082	±20	0.20	1MHz/50mV	450	280
ML3216PR10MT	0.10	±20	0.20	1MHz/50mV	350	235
ML3216PR12MT	0.12	±20	0.20	1MHz/50mV	350	220
ML3216PR15MT	0.15	±20	0.20	1MHz/50mV	350	200
ML3216PR18MT	0.18	±20	0.20	1MHz/50mV	350	185
ML3216PR22MT	0.22	±20	0.20	1MHz/50mV	350	170
ML3216PR27MT	0.27	±20	0.20	1MHz/50mV	350	150
ML3216PR33MT	0.33	±20	0.20	1MHz/50mV	350	145
ML3216PR39MT	0.39	±20	0.30	1MHz/50mV	220	135
ML3216PR47MT	0.47	±20	0.30	1MHz/50mV	220	125
ML3216PR56MT	0.56	±20	0.30	1MHz/50mV	220	115
ML3216PR68MT	0.68	±20	0.30	1MHz/50mV	220	105
ML3216PR82MT	0.82	±20	0.30	1MHz/50mV	220	100

All specifications are subject to change without notice.

ML3216P Electrical Characteristics

Part Number	Inductance (uH)	Tolerance (%)	DCR max. (Ω)	Freq./voltage (MHz/mV)	Rated Current(mA)max	SRF min. (MHz)
ML3216P1R0MT	1.0	±20	0.20	1MHz/50mV	250	75
ML3216P1R2MT	1.2	±20	0.20	1MHz/50mV	250	65
ML3216P1R5MT	1.5	±20	0.25	1MHz/50mV	250	60
ML3216P1R8MT	1.8	±20	0.25	1MHz/50mV	250	55
ML3216P2R2MT	2.2	±20	0.30	1MHz/50mV	200	50
ML3216P2R7MT	2.7	±20	0.30	1MHz/50mV	200	45
ML3216P3R3MT	3.3	±20	0.30	1MHz/50mV	200	41
ML3216P3R9MT	3.9	±20	0.35	1MHz/50mV	150	38
ML3216P4R7MT	4.7	±20	0.35	1MHz/50mV	150	35
ML3216P5R6MT	5.6	±20	0.50	1MHz/50mV	100	32
ML3216P6R8MT	6.8	±20	0.50	1MHz/50mV	100	29
ML3216P8R2MT	8.2	±20	0.50	1MHz/50mV	100	26
ML3216P100MT	10	±20	0.50	1MHz/50mV	100	24
ML3216P120MT	12	±20	0.60	1MHz/50mV	100	22
ML3216P150MT	15	±20	0.80	1MHz/50mV	50	19
ML3216P180MT	18	±20	0.80	1MHz/50mV	50	18
ML3216P220MT	22	±20	1.00	1MHz/50mV	50	16
ML3216P270MT	27	±20	1.00	1MHz/50mV	50	14

• Test equipment

Inductance : HP4291A+16193A, or equivalent

Tolerance: M=±20%

SRF: HP8720C, or equivalent

Rdc: YOKOGAWA TYPE7561, or equivalent

Product outline

- Ferrite material multilayer chip BEADS, miniature size, suitable for SMT process.
- Internal silver printed layers and magnetic shielded structures to minimize crosstalk.
- High impedance in wide range of frequency to suppress EMI.
- Beads for both signal and power line are available.



Dimensions(mm)

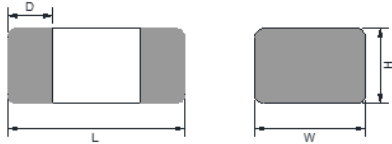

Recommended Patterns

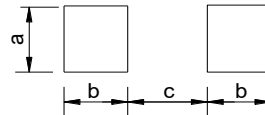

Type	L	W	H	D	a	b	c	Packaging (pcs/reel)
1005	1.0±0.15	0.5±0.15	0.5±0.15	0.25±0.1	0.45±0.1	0.4±0.1	0.45±0.1	10000
1608	1.6±0.2	0.8±0.2	0.8±0.2	0.3±0.2	0.7±0.1	0.7±0.1	0.7±0.1	4000
2012	2.0±0.2	1.2±0.2	0.9±0.2	0.5±0.3	1.2±0.2	0.8±0.2	1.0±0.2	4000
3216	3.2±0.2	1.6±0.2	0.9±0.2	0.5±0.3	1.8±0.2	0.8±0.2	2.0±0.2	4000

Dimensions without tolerance are typical.

Product Identification

FB **2012** **S** **121** **T**

① ② ③ ④ ⑤

- ① Ferrite Beads Series:
- ② Dimensions: 0603(inch)=1608(mm)=1.6x0.8mm
- ③ S=General use,
W=High current beads for Power Lines,
H=Super high current beads for Power Lines,
- ④ Impedance Value: 260=26Ω, 121=120Ω, 102=1000Ω
- ⑤ Packaging: T=TAPING&REEL

FB1005S Electrical Characteristics

Part Number	Impedance (Ω) ①	Test Frequency (MHz)/ 50mV	DCR max. (mΩ) ②	Rated Current (A)
FB1005S050T	0~15	100	50	0.5
FB1005S260T	26±25%	100	130	0.3
FB1005S310T	31±25%	100	200	0.3
FB1005S360T	36±25%	100	200	0.3
FB1005S600T	60±25%	100	300	0.2
FB1005S800T	80±25%	100	350	0.2
FB1005S101T	100± 25%	100	350	0.2
FB1005S121T	120±25%	100	400	0.2
FB1005S151T	150±25%	100	470	0.2
FB1005S181T	180±25%	100	520	0.15
FB1005S201T	200±25%	100	520	0.15
FB1005S221T	220±25%	100	520	0.15
FB1005S301T	300±25%	100	650	0.1
FB1005S501T	500±25%	100	900	0.1
FB1005S601T	600±25%	100	1000	0.1
FB1005S801T	800±25%	100	1300	0.1
FB1005S102T	1000±25%	100	1400	0.1

FB1005W Electrical Characteristics

Part Number	Impedance (Ω) ①	Test Frequency (MHz)/ 50mV	DCR max. (mΩ) ②	Rated Current (A)
FB1005W050T	0~15	100	40	1.8
FB1005W260T	26±25%	100	60	1.8
FB1005W310T	31±25%	100	80	1.8
FB1005W600T	60±25%	100	130	1.0
FB1005W800T	80±25%	100	170	1.0
FB1005W101T	100± 25%	100	200	0.9
FB1005W121T	120±25%	100	250	0.7
FB1005W151T	150±25%	100	250	0.7
FB1005W181T	180±25%	100	300	0.7
FB1005W201T	200±25%	100	300	0.7
FB1005W221T	220±25%	100	300	0.7
FB1005W301T	300±25%	100	400	0.4
FB1005W501T	500±25%	100	600	0.3
FB1005W601T	600±25%	100	600	0.3
FB1005W801T	800±25%	100	800	0.25
FB1005W102T	1000±25%	100	900	0.25

All specifications are subject to change without notice.

FB1005H Electrical Characteristics

Part Number	Impedance (Ω) ①	Test Frequency (MHz)/ 50mV	DCR max. (mΩ) ②	Rated Current (A)
FB1005H110T	7~15	100	20	2.0
FB1005H190T	12~25	100	35	1.9
FB1005H260T	26±25%	100	60	1.9
FB1005H300T	30±25%	100	60	1.9
FB1005H600T	60±25%	100	100	1.3
FB1005H101T	100±25%	100	150	1.0
FB1005H121T	120±25%	100	150	1.0
FB1005H151T	150±25%	100	200	0.7
FB1005H201T	200±25%	100	250	0.7
FB1005H221T	220±25%	100	280	0.7
FB1005H301T	300±25%	100	300	0.6
FB1005H501T	500±25%	100	400	0.5
FB1005H601T	600±25%	100	500	0.5
FB1005H801T	800±25%	100	650	0.3
FB1005H102T	1000±25%	100	650	0.3

FB1608S Electrical Characteristics

Part Number	Impedance (Ω) ①	Test Frequency (MHz)/ 50mV	DCR max. (mΩ) ②	Rated Current (A)
FB1608S050T	0~15	100	50	2.0
FB1608S260T	26±25%	100	50	2.0
FB1608S310T	31±25%	100	50	1.0
FB1608S600T	60±25%	100	150	0.4
FB1608S700T	70±25%	100	150	0.4
FB1608S800T	80±25%	100	150	0.4
FB1608S101T	100± 25%	100	200	0.3
FB1608S121T	120±25%	100	200	0.3
FB1608S151T	150±25%	100	200	0.3
FB1608S181T	180±25%	100	300	0.3
FB1608S221T	220±25%	100	300	0.3
FB1608S301T	300±25%	100	350	0.2
FB1608S501T	500±25%	100	450	0.2
FB1608S601T	600±25%	100	450	0.2
FB1608S801T	800±25%	100	600	0.2
FB1608S102T	1000±25%	100	600	0.2
FB1608S122T	1200±25%	100	700	0.2
FB1608S152T	1500±25%	100	700	0.2
FB1608S182T	1800±25%	100	900	0.15
FB1608S202T	2000±25%	100	1100	0.15
FB1608S222T	2200±25%	100	1200	0.1
FB1608S252T	2500±25%	100	1300	0.05

All specifications are subject to change without notice.

FB1608W Electrical Characteristics

Part Number	Impedance (Ω) ①	Test Frequency (MHz)/ 50mV	DCR max. (mΩ) ②	Rated Current (A)
FB1608W050T	0~15	100	20	3.0
FB1608W190T	12~25	100	30	3.0
FB1608W260T	26±25%	100	30	3.0
FB1608W300T	30±25%	100	30	3.0
FB1608W310T	31±25%	100	30	3.0
FB1608W500T	50±25%	100	100	1.5
FB1608W600T	60±25%	100	100	1.5
FB1608W700T	70± 25%	100	100	1.5
FB1608W800T	80±25%	100	100	1.5
FB1608W101T	100±25%	100	120	1.4
FB1608W121T	120±25%	100	140	1.3
FB1608W151T	150±25%	100	150	1.2
FB1608W181T	180±25%	100	150	1.2
FB1608W221T	220±25%	100	180	1.2
FB1608W301T	300±25%	100	200	1.2
FB1608W501T	500±25%	100	300	1.0
FB1608W601T	600±25%	100	300	1.0
FB1608W801T	800±25%	100	350	0.5
FB1608W102T	1000±25%	100	400	0.5
FB1608W122T	1200±25%	100	450	0.5
FB1608W152T	1500±25%	100	550	0.4
FB1608W182T	1800±25%	100	550	0.4
FB1608W202T	2000±25%	100	600	0.4
FB1608W252T	2500±25%	100	650	0.4

FB1608H Electrical Characteristics

Part Number	Impedance (Ω) ①	Test Frequency (MHz)/ 50mV	DCR max. (mΩ) ②	Rated Current (A)
FB1608H050T	0~15	100	10	6.0
FB1608H260T	26±25%	100	30	5.0
FB1608H300T	30±25%	100	30	4.0
FB1608H500T	50±25%	100	40	3.0
FB1608H600T	60±25%	100	40	3.0
FB1608H700T	70±25%	100	60	2.5
FB1608H750T	75±25%	100	60	2.5
FB1608H800T	80± 25%	100	60	2.5
FB1608H101T	100±25%	100	60	2.5
FB1608H121T	120±25%	100	65	2.0
FB1608H151T	150±25%	100	70	1.5
FB1608H181T	180±25%	100	90	1.5
FB1608H221T	220±25%	100	120	1.5
FB1608H301T	300±25%	100	150	1.5
FB1608H331T	330±25%	100	180	1.3
FB1608H501T	500±25%	100	180	1.3
FB1608H601T	600±25%	100	180	1.3
FB1608H801T	800±25%	100	300	0.8
FB1608H102T	1000±25%	100	350	0.7

All specifications are subject to change without notice.

FB2012S Electrical Characteristics

Part Number	Impedance (Ω) ①	Test Frequency (MHz)/ 50mV	DCR max. (mΩ) ②	Rated Current (A)
FB2012S090T	5~13	100	40	2.2
FB2012S260T	26±25%	100	50	1.5
FB2012S310T	31±25%	100	50	1.5
FB2012S600T	60±25%	100	100	1.0
FB2012S800T	80±25%	100	100	1.0
FB2012S101T	100±25%	100	150	0.8
FB2012S121T	120±25%	100	150	0.8
FB2012S151T	150±25%	100	180	0.7
FB2012S181T	180±25%	100	180	0.7
FB2012S221T	220±25%	100	200	0.6
FB2012S301T	300±25%	100	200	0.6
FB2012S501T	500±25%	100	300	0.55
FB2012S601T	600±25%	100	300	0.55
FB2012S801T	800±25%	100	350	0.5
FB2012S102T	1000±25%	100	350	0.5
FB2012S122T	1200±25%	100	400	0.5
FB2012S152T	1500±25%	100	400	0.5
FB2012S202T	2000±25%	100	450	0.5
FB2012S252T	2500±25%	50	500	0.4

FB2012W Electrical Characteristics

Part Number	Impedance (Ω) ①	Test Frequency (MHz)/ 50mV	DCR max. (mΩ) ②	Rated Current (A)
FB2012W090T	5~13	100	20	3.0
FB2012W190T	12~25	100	20	3.0
FB2012W310T	31±25%	100	40	3.0
FB2012W600T	60±25%	100	50	3.0
FB2012W800T	80±25%	100	60	3.0
FB2012W101T	100±25%	100	80	2.5
FB2012W121T	120±25%	100	80	2.5
FB2012W151T	150±25%	100	100	2.5
FB2012W181T	180±25%	100	120	2.0
FB2012W221T	220±25%	100	130	2.0
FB2012W301T	300±25%	100	130	2.0
FB2012W501T	500±25%	100	220	1.5
FB2012W601T	600±25%	100	220	1.5
FB2012W801T	800±25%	100	250	1.0
FB2012W102T	1000±25%	100	250	1.0
FB2012W122T	1200±25%	100	280	0.8
FB2012W152T	1500±25%	100	400	0.7
FB2012W202T	2000±25%	100	400	0.7
FB2012W252T	2500±25%	50	450	0.6

All specifications are subject to change without notice.

FB2012H Electrical Characteristics

Part Number	Impedance (Ω) ①	Test Frequency (MHz)/ 50mV	DCR max. (mΩ)②	Rated Current (A)
FB2012H090T	5~13	100	10	6.0
FB2012H190T	12~25	100	10	6.0
FB2012H310T	31±25%	100	10	6.0
FB2012H600T	60±25%	100	30	4.0
FB2012H800T	80±25%	100	40	4.0
FB2012H101T	100±25%	100	45	4.0
FB2012H121T	120±25%	100	45	4.0
FB2012H151T	150±25%	100	70	3.0
FB2012H181T	180±25%	100	70	3.0
FB2012H221T	220±25%	100	70	3.0
FB2012H301T	300±25%	100	80	2.5
FB2012H501T	500±25%	100	90	2.5
FB2012H601T	600±25%	100	100	2.0
FB2012H801T	800±25%	100	120	1.5
FB2012H102T	1000±25%	100	120	1.5

FB3216S Electrical Characteristics

Part Number	Impedance (Ω) ①	Test Frequency (MHz)/ 50mV	DCR max (mΩ) .②	Rated Current (A)
FB3216S090T	5~13	100	50	2.0
FB3216S260T	26±25%	100	50	2.0
FB3216S600T	60±25%	100	100	1.0
FB3216S750T	75±25%	100	100	1.0
FB3216S800T	80±25%	100	100	1.0
FB3216S101T	100±25%	100	100	1.0
FB3216S121T	120±25%	100	100	1.0
FB3216S151T	150±25%	100	150	1.0
FB3216S181T	180±25%	100	150	1.0
FB3216S221T	220±25%	100	200	0.8
FB3216S301T	300±25%	100	200	0.8
FB3216S501T	500±25%	100	300	0.6
FB3216S601T	600±25%	100	300	0.6
FB3216S801T	800±25%	100	350	0.6
FB3216S102T	1000±25%	100	350	0.6
FB3216S122T	1200±25%	100	600	0.3
FB3216S152T	1500±25%	50	600	0.3
FB3216S202T	2000±25%	50	1000	0.1
FB3216S252T	2500±25%	50	1200	0.05
FB3216S302T	3000±25%	50	1500	0.05

①Impedance : HP4291A+16193A, or equivalent.

②Rdc: YOKOGAWA TYPE7561, or equivalent.

FB3216W Electrical Characteristics

Part Number	Impedance (Ω) ①	Test Frequency (MHz)/ 50mV	DCR max. (mΩ) ②	Rated Current (A)
FB3216W090T	5~13	100	40	4.0
FB3216W260T	26±25%	100	40	3.0
FB3216W310T	31±25%	100	40	3.0
FB3216W500T	50±25%	100	40	3.0
FB3216W600T	60±25%	100	40	3.0
FB3216W800T	80±25%	100	70	3.0
FB3216W101T	100±25%	100	70	3.0
FB3216W121T	120±25%	100	70	3.0
FB3216W151T	150±25%	100	100	2.5
FB3216W181T	180±25%	100	100	2.5
FB3216W221T	220±25%	100	110	2.5
FB3216W301T	300±25%	100	150	2.0
FB3216W501T	500±25%	100	200	2.0
FB3216W601T	600± 25%	100	200	2.0
FB3216W801T	800±25%	100	250	2.0
FB3216W102T	1000±25%	100	250	2.0
FB3216W122T	1200±25%	100	350	1.5
FB3216W152T	1500±25%	50	450	0.5
FB3216W182T	1800±25%	50	600	0.5
FB3216W202T	2000±25%	50	700	0.3
FB3216W252T	2500±25%	50	900	0.2

FB3216H Electrical Characteristics

Part Number	Impedance (Ω) ①	Test Frequency (MHz)/ 50mV	DCR max. (mΩ) ②	Rated Current (A)
FB3216H090T	5~13	100	10	6.0
FB3216H260T	26±25%	100	15	6.0
FB3216H310T	31±25%	100	20	5.0
FB3216H500T	50±25%	100	20	5.0
FB3216H600T	60±25%	100	25	5.0
FB3216H800T	80±25%	100	35	4.0
FB3216H101T	100±25%	100	35	4.0
FB3216H121T	120±25%	100	35	4.0
FB3216H151T	150±25%	100	45	3.0
FB3216H181T	180±25%	100	55	3.0
FB3216H221T	220±25%	100	55	3.0
FB3216H301T	300±25%	100	65	2.5
FB3216H401T	400±25%	100	75	2.5
FB3216H501T	500±25%	100	80	2.5
FB3216H601T	600± 25%	100	80	2.2
FB3216H801T	800±25%	100	110	2.1
FB3216H102T	1000±25%	100	120	2.1

① Impedance : HP4291A+16193A, or equivalent.

② Rdc: YOKOGAWA TYPE7561, or equivalent.

1. Dimensions (mm)

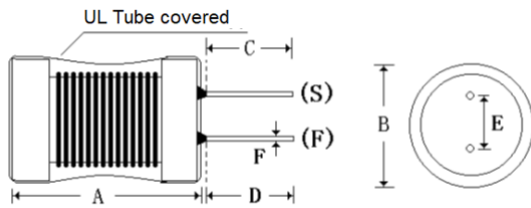

2. Schematics

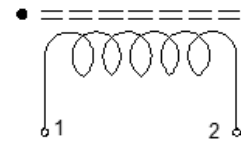

Type	A	B	C	D	E	F
TDR0406	8.5 max.	5.5 max.	15 REF	15 REF.	2.0±0.5	0.5±0.1
TDR0507	9.0 max.	6.5 max.	15 REF	15 REF.	2.5±0.5	0.5±0.1
TDR0608	11.0 max.	8.0 max.	15 REF	15 REF.	2.5±0.5	0.60±0.1
TDR0610	12.5 max.	8.5 max.	15 REF	15 REF.	3.0±0.5	0.60±0.1
TDR0612	14.0 max.	8.5 max.	15 REF	15 REF.	3.0±0.5	0.60±0.1
TDR0810	13.0max.	9.0max.	15 REF	15 REF.	5.0±0.5	0.60±0.1
TDR0912	15.0max.	10.0max.	15 REF	15 REF.	5.0±0.5	0.60±0.1
TDR1012S	14.5 max.	11.5 max.	15 REF	15 REF.	6.0±0.5	0.60±0.1
TDR1016S	18.5 max.	11.5 max.	15 REF	15 REF.	6.0±0.5	0.60±0.1
TDR1419S	21.0 max.	17.0 max.	15 REF	15 REF.	7.5±0.5	0.80±0.1
TDR1618S	22.0 max.	18.0 max.	15 REF	15 REF.	10.0±0.5	1.0±0.1

- ① Dimensions do not include the solder on the terminal pins.
- ② C pin length to be according to customer's request.

TDR0406 Electrical Characteristics

Part Number	Inductance (μH) ①	Inductance Tolerance	DCR max. (mΩ) ②	Isat Typ. (A) ③
TDR0406S-2R2MB01	2.2	±20%	26	2.90
TDR0406S-3R3MB01	3.3	±20%	50	2.58
TDR0406S-4R7MB01	4.7	±20%	55	2.5
TDR0406S-6R8KB01	6.8	±10%	65	2.15
TDR0406S-220KB01	22	±10%	160	1.10
TDR0406S-470KB01	47	±10%	500	0.75
TDR0406S-221KB01	220	±10%	1800	0.35
TDR0406S-471KB01	470	±10%	3800	0.23
TDR0406S-102KB01	1000	±10%	8500	0.16

TDR0507 Electrical Characteristics

Part Number	Inductance (μH) ①	Inductance Tolerance	DCR max. (mΩ) ②	Isat Typ. (A) ③
TDR0507S-100KB01	10	±10%	120	1.5
TDR0507S-121KB01	120	±10%	650	0.5
TDR0507S-220KB01	220	±10%	1250	0.4
TDR0507S-681KB01	680	±10%	3600	0.24
TDR0507S-102KB01	1000	±10%	6000	0.18

TDR0608 Electrical Characteristics

Part Number	Inductance (μH) ①	Inductance Tolerance	DCR max. (mΩ) ②	Isat Typ. (A) ③
TDR0608S-3R3MB01	3.3	±20%	60	4.0
TDR0608S-4R7MB01	4.7	±20%	70	3.5
TDR0608S-6R8MB01	6.8	±20%	80	3.0
TDR0608S-100KB01	10	±10%	90	2.3
TDR0608S-220KB01	22	±10%	140	1.2
TDR0608S-330KB01	33	±10%	190	0.9
TDR0608S-470KB01	47	±10%	230	0.83
TDR0608S-680KB01	68	±10%	370	0.75
TDR0608S-101KB01	100	±10%	440	0.68
TDR0608S-151KB01	150	±10%	730	0.60
TDR0608S-221KB01	220	±10%	920	0.50
TDR0608S-331KB01	330	±10%	1500	0.40
TDR0608S-471KB01	470	±10%	2300	0.35
TDR0608S-561KB01	560	±10%	3000	0.30
TDR0608S-821KB01	820	±10%	4160	0.21
TDR0608S-102KB01	1000	±10%	4550	0.18
TDR0608S-122KB01	1200	±10%	5200	0.16
TDR0608S-152KB01	1500	±10%	6000	0.15
TDR0608S-222KB01	2200	±10%	8320	0.11
TDR0608S-272KB01	2700	±10%	9620	0.11
TDR0608S-332KB01	3300	±10%	10920	0.10
TDR0608S-472KB01	4700	±10%	17810	0.085

TDR0610 Electrical Characteristics

Part Number	Inductance (μH) ①	Inductance Tolerance	DCR max. (mΩ) ②	Isat Typ. (A) ③
TDR0610S-2R2KB01	2.2	±10%	15.5	5.0
TDR0610S-101KB01	100	±10%	320	0.60
TDR0610S-301KB01	300	±10%	750	0.45
TDR0610S-102KB01	1000	±10%	2600	0.20
TDR0610S-252KB01	2500	±10%	6000	0.18

TDR0612 Electrical Characteristics

Part Number	Inductance (μH) ①	Inductance Tolerance	DCR max. (mΩ) ②	Isat Typ. (A) ③
TDR0612S-102KB01	1000	±10%	2250	0.24
TDR0612S-202KB01	2000	±10%	3800	0.17

- ① Inductance Test Freq:1kHz / 0.25V.
- ② DCR measured on a micro-ohmmeter.
- ③ Isat based on ΔL / LOA=10% typ.

TDR0810 Electrical Characteristics

Part Number	Inductance (μH) ①	Inductance Tolerance	DCR max. (mΩ) ②	Isat Typ. (A) ③
TDR0810S-3R3MB01	3.3	±20%	40	6.0
TDR0810S-4R7MB01	4.7	±20%	60	4.5
TDR0810S-6R8MB01	6.8	±20%	60	4.0
TDR0810S-100KB01	10	±10%	90	3.5
TDR0810S-220KB01	22	±10%	130	3.0
TDR0810S-330KB01	33	±10%	160	2.5
TDR0810S-470KB01	47	±10%	170	1.8
TDR0810S-680KB01	68	±10%	230	1.1
TDR0810S-101KB01	100	±10%	290	0.9
TDR0810S-151KB01	150	±10%	460	0.75
TDR0810S-221KB01	220	±10%	620	0.60
TDR0810S-331KB01	330	±10%	790	0.45
TDR0810S-471KB01	470	±10%	1200	0.45
TDR0810S-681KB01	680	±10%	1500	0.45
TDR0810S-102KB01	1000	±10%	2000	0.28
TDR0810S-122KB01	1200	±10%	2700	0.28
TDR0810S-182KB01	1800	±10%	3500	0.20
TDR0810S-222KB01	2200	±10%	4200	0.17
TDR0810S-332KB01	3300	±10%	6100	0.14

TDR0912S Electrical Characteristics

Part Numer	Inductance (μH) ①	Inductance Tolerance	DCR max. (mΩ) ②	Isat Typ. (A) ③
TDR0912S-100KB01	10	±10%	60	4.5
TDR0912S-150KB01	15	±10%	80	3.8
TDR0912S-220KB01	22	±10%	100	3.2
TDR0912S-330KB01	33	±10%	120	2.8
TDR0912S-470KB01	47	±10%	130	2.2
TDR0912S-680KB01	68	±10%	150	1.9
TDR0912S-101KB01	100	±10%	250	1.5
TDR0912S-151KB01	150	±10%	320	0.9
TDR0912S-221KB01	220	±10%	530	0.70
TDR0912S-331KB01	330	±10%	850	0.55
TDR0912S-471KB01	470	±10%	1100	0.50
TDR0912S-681KB01	680	±10%	1300	0.40
TDR0912S-102KB01	1000	±10%	2000	0.35
TDR0912S-152KB01	1500	±10%	2900	0.28
TDR0912S-222KB01	2200	±10%	4500	0.23

① Inductance Test Freq: 1kHz / 0.25V.

② DCR measured on a micro-ohmmeter.

③ Isat based on ΔL / LOA=10% typ.

TDR1012S Electrical Characteristics

Part Number	Inductance (μH) ①	Inductance Tolerance	DCR max. (mΩ) ②	Isat Typ. (A) ③
TDR1012S-100MB01	10	±20%	25	5.3
TDR1012S-150MB01	15	±20%	40	5.2
TDR1012S-220KB01	22	±10%	45	3.6
TDR1012S-470KB01	47	±10%	76	2.5
TDR1012S-680KB01	68	±10%	95	2.1
TDR1012S-101KB01	100	±10%	145	1.7
TDR1012S-151KB01	150	±10%	190	1.52
TDR1012S-221KB01	220	±10%	320	1.20
TDR1012S-331KB01	330	±10%	420	1.0
TDR1012S-681KB01	680	±10%	830	0.65
TDR1012S-102KB01	1000	±10%	1350	0.50
TDR1012S-122KB01	1200	±10%	2500	0.42
TDR1012S-222KB01	2200	±10%	3000	0.35

TDR1016S Electrical Characteristics

Part Number	Inductance (μH) ①	Inductance Tolerance	DCR max. (mΩ) ②	Isat Typ. (A) ③
TDR1016S-221KB01	220	±10%	220	1.5
TDR1016S-241KB01	240	±10%	320	1.4
TDR1016S-471KB01	470	±10%	650	1.2
TDR1016S-102KB01	1000	±10%	1200	0.75
TDR1016S-222KB01	2200	±10%	2200	0.32

TDR1419S Electrical Characteristics

Part Number	Inductance (μH) ①	Inductance tolerance	DCR (mΩ) ②	Isat max. (A) ③	Irms typ. (A) ④
TDR1419S-501KB01	500	±10%	350 ± 25%	2.5	1.6
TDR1419S-571KB01	570	±10%	370 ± 25%	2.4	1.5
TDR1419S-102KB01	1000	±10%	480 ± 30%	1.5	1.3

TDR1618S Electrical Characteristics

Part Number	Inductance (μH) ①	Inductance tolerance	DCR typ (mΩ) ②	Isat Typ. (A) ③	Irms Typ. (A) ④
TDR1618S-350KB01	35	±10%	40	14	6.5

- ① Inductance Test Freq:1kHz / 0.25V.
- ② DCR measured on a micro-ohmmeter.
- ③ Isat based on ΔL / LOA=10% typ.
- ④ Irms based on Temp. rise 40°C typ.

Custom Design is also available to meet your exact requirements

General Characteristics

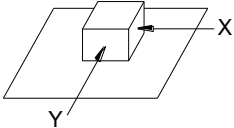
Items	Performance	Requirements
Operating Temperature Range	-40°C to +125°C (Including self-heating)	
Storage Temperature Range	-40°C to +125°C	
Terminal Strength AEC-Q200-006	The terminal electrode and the ferrite core shall not be peeled off and/or damaged.	10N force Keep time: 5s 
Vibration MIL-STD-202 Method 204	No visible mechanical damage. Inductance deviation: within ±10%.	Frequency: 10~55~10 Hz for 15 min. Amplitude: 1.5mm Directions: X, Y, Z directions Times: 2 hours for each orientation Total Time: 6 hours
Insulating Resistance MIL-STD-202 Method 302	Over 100MΩ	100V D.C. between windings and core
Dielectric Strength MIL-STD-202 Method 301	No visible mechanical damage.	100V D.C for 1 minute between windings and core
Solderability ANSI/J-STD-002	90% or more of electrode area shall be coated by new solder.	Solder temperature: 245±5°C Duration: 5±1 sec. Solder: Sn/3.0Ag/0.5Cu Flux: 25% resin and 75% ethanol in weight Fluxed electrode shall be immersed in solder bath.
Thermal Shock MIL-STD-202 Method 107	No visible mechanical damage. Inductance deviation: within ±10%.	Temperature and time: -40±3°C for 30±3min→125°C for 30±3min Transfer interval: Max. 20 sec Tested cycle: 10 cycles Measured after exposure under the room conditions for 2~3 hours
Low Temperature Storage JESD22-A119	No visible mechanical damage. Inductance deviation: within ±10%.	Temperature: -40±3°C Duration: 500±24 hours Measured after exposure under the room conditions for 2~3 hours
High Temperature Storage MIL-STD-202 Method 108	No visible mechanical damage. Inductance deviation: within ±10%.	Temperature: 125±2°C Duration: 500±24 hours Measured after exposure under the room conditions for 2~3 hours
Humidity Test MIL-STD-202 Method 103	No visible mechanical damage. Inductance deviation: within ±10%.	Temperature: 40±2°C Humidity: 90% to 95%RH Duration: 500±24 hours Measured after exposure under the room conditions for 2~3 hours

All specifications are subject to change without notice.

Reflow Soldering Conditions

Reflow Soldering Heat Endurance

Reflow profile parameters

- (1) Preheat condition: 150 ~200°C/60~120sec.
- (2) Ramp-up rate(T_L to T_P):3°C/sec. max.
- (3) Allowed time above 217°C: 60~90sec.
- (4) Allowed time above 230°C: 60sec.
- (5) Peak temp: 260°C
- (6) Max time at peak temp: 5sec.
- (7) Ramp-down rate(T_P to T_L):6 °C/sec max.

Recommended solder paste: Sn/3.0Ag/0.5Cu
 Liquidous temperature $T_L=217^\circ\text{C}$

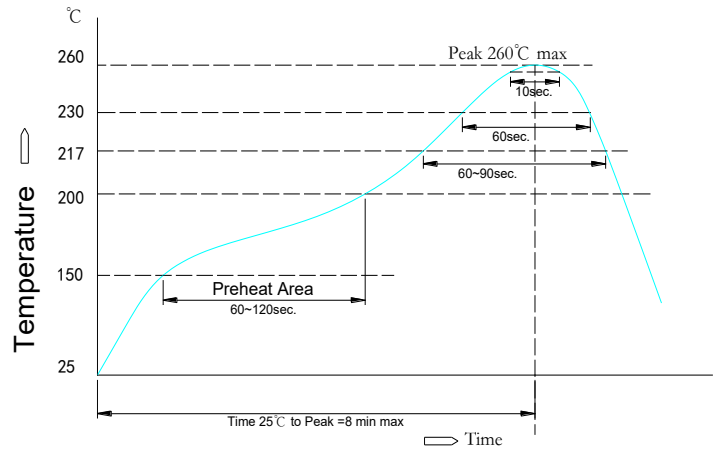

Note:

- (1) No mechanical and electrical defects are found after testing based on the above profile and keeping under the conditions of room temperature and humidity for 2 hours.
- (2) 2 times reflow test is acceptable with the test interval remaining 1 hour under the normal conditions.
- (3) This reflow profile is for classification/preconditioning and are not meant to specify board assembly profiles,Actual board assembly profile should be developed based on specific process needs and board designs and **should not exceed** the parameters listed above.
- (4) The reflow test profile may vary with the testing instruments.

Recommended Reflow Conditions

Reflow profile parameters

- (1) Preheat condition: 150 ~200°C/60~120sec.
- (2) Ramp-up rate(T_L to T_P):3°C/sec. max.
- (3) Allowed time above 217°C: 60~90sec.
- (4) Allowed time above 230°C: 40sec.
- (5) Peak temp: 245°C
- (6) Ramp-down rate(T_P to T_L):6 °C/sec. max.

Recommended solder paste: Sn/3.0Ag/0.5Cu
 Liquidous temperature $T_L=217^\circ\text{C}$

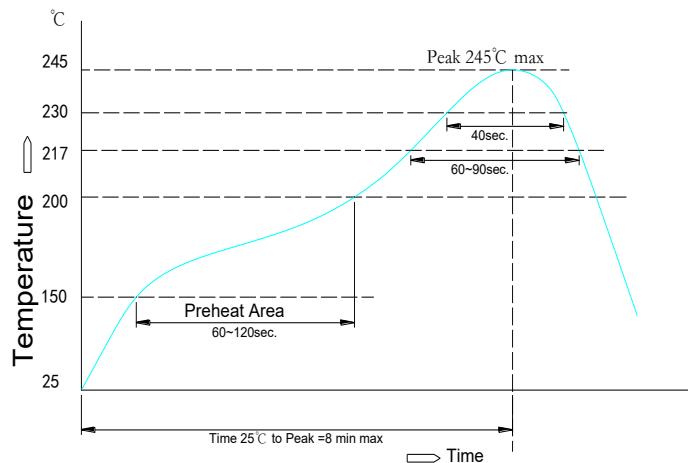

Note:

The recommended reflow profile here is for classification/preconditioning, Actual board assembly profile is based on the testing instruments used, **Solderability** depends on the testing equipments,reflow conditions, testing method,etc.so it is necessary to make a confirmation of them when the reflow conditions are set up.

京特電子有限公司
KYOTOKU Electronics Co.,Ltd.
6/F Manulife Place 348 Kwun Tong Road KL HONGKONG

杭州京拓电子有限公司
KYOTOKU (Hangzhou) Electronics Co.,Ltd.
杭州市西湖区文一西路588号西溪首座5号

Mail: hiro@kyotoku-magnetics.com
www.kyotoku-magnetics.com